

Installation Operation and Maintenance

LaBour Horizontal Pumps **SQ & SZ**

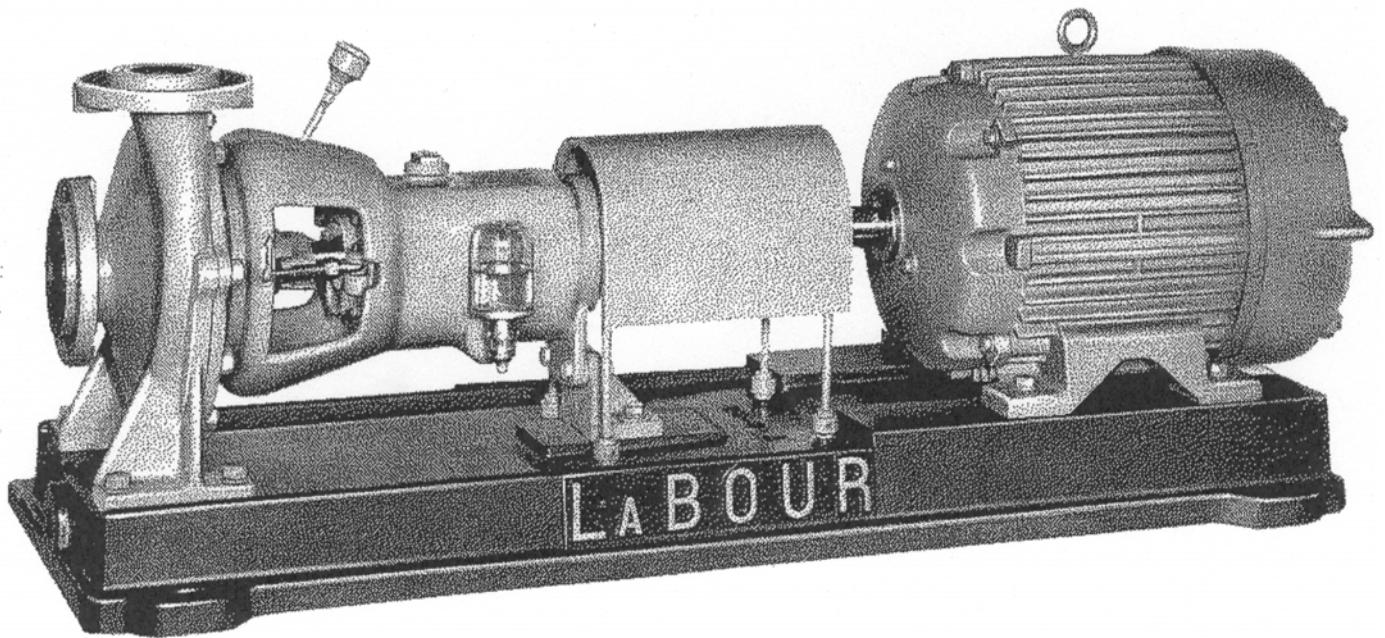

Labour – Taber Pumps

P. O. Box 7026 Indianapolis, Indiana 46207-7026

Ph. (317) 925-9661 Fax. (317) –920-6605

SQ &SZ

Rev. 03-23-04

Instructions for the Care and Operation of LaBour Type SZ and SQ Pumps

This bulletin is intended to give information on the proper installation and maintenance of LaBour centrifugal pumps of the horizontal types. The description of the operating characteristics and the mechanical construction will acquaint the operator with the general construction of this equipment. The hints as to where to look for trouble in case of improper operation, as found in the last few pages of this bulletin, should be of help to the pump operator and maintenance department.

The following drawings apply to this
pump Serial No.
Drawing Numbers

specific gravity of the liquid being handled. Wide variations in the viscosity will change somewhat the pumping characteristics, but as long as the head is expressed in feet and not in pounds pressure, the capacity-head characteristics are the same, regardless of the specific gravity. The power

required to drive the unit will vary in direct proportion to the specific gravity of the liquid.

INSTALLATION OF PUMP

The pump should be so located that it is readily accessible in order that proper attention may be given, and should be placed a foot or more above floor level, thus making maintenance more convenient. The suction and discharge pipes must properly match the companion flanges on the pump and no strain must occur in connecting the pipes. The pumps are not designed to carry any appreciable mechanical load on either the suction or discharge openings and if the piping must be strained to make the final connection at the pump, trouble will result.

CAPACITY OF THE PUMP

Pumping capacities are ordinarily expressed in terms of volume of liquid handled per unit time; together with the total head against which the pump is to operate. The capacity of the pump is generally given in gallons per minute (GPM), and the head is expressed in feet.

the performance will generally be the same regardless of the

MATERIALS OF CONSTRUCTION

LaBour pumps are furnished in a wide variety of construction materials, these being especially selected for the liquids to be handled and the duty to be performed. When the pump leaves the factory it is tagged, indicating the metal used in the pump casing and also indicating the metal of which the impeller is made. Care should be taken to see that pumps constructed of given metals are applied only for handling liquids for which they are suitable.

STARTING THE PUMP

If the installation has been properly made, the pump is ready for starting. A careful check should be made to see that no foreign material has become lodged in the pump. When the pump leaves the factory, the suction and discharge openings have been closed in order to protect the pump.

The bearing bracket is supplied with the proper amount of lubricant suitable for indoor operation at ordinary temperatures. The housing completely encloses the bearings and nothing could ordinarily get into the bearings. A check should, however, be made to be certain that the drain and filling plugs are in place and that the lubricant is up to the proper level.

The direction of rotation should be checked by referring to the arrow on the pump bearing bracket.

GIVE PART NUMBER AND PUMP SERIAL NUMBER WHEN ORDERING REPAIRS

First step in dismantling the drive unit is removal of the coupling guard.

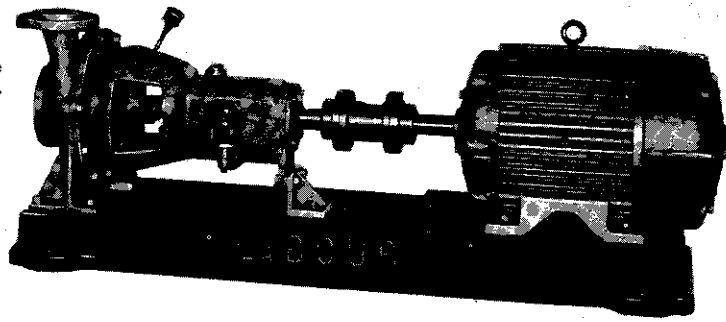

Take out the flexible coupling spacer to permit the drive unit to be pulled away from the casing.

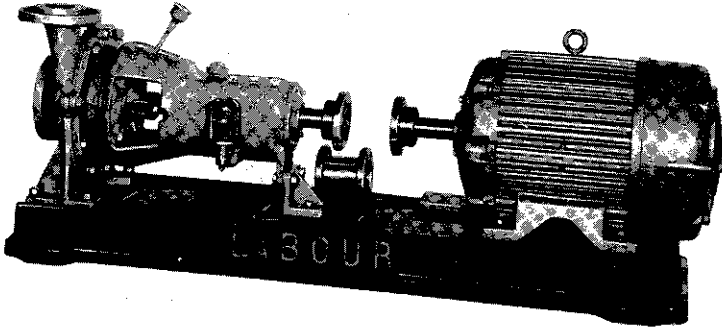

Now the drive unit can be disconnected and removed as an assembly for replacement or repair.

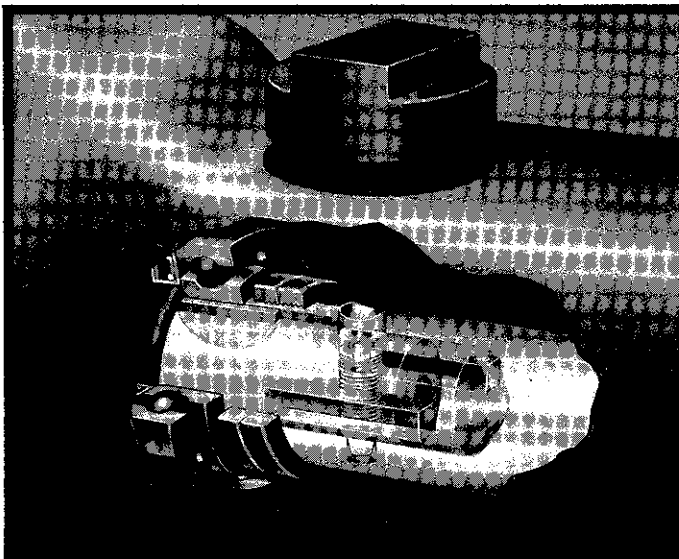
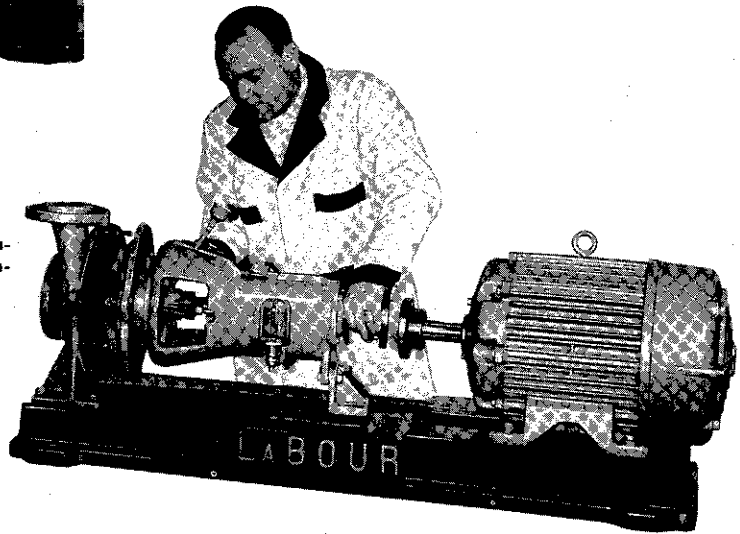

SEPARABLE SHAFT MOUNTING (QC)

As shown in this phantom illustration, the separable impeller shaft is held in place without the use of set screws or other parts exposed to corrosive liquids or fumes. Access to the junction is obtained by removing the breather plug located in the top of the bearing bracket. The lock screw is backed up to disengage it from the drive shaft, after which the shaft is rotated 90° to bring the slot into a vertical position. A drift key now introduced through the breather opening and into the slot is used to force out the impeller shaft with its key and all the slinger parts.

LaBour pumps rotate clockwise when looking at the coupling end of the pump.

To meet specified pumping conditions, each pump must operate at a definite speed, and any appreciable change from this speed will materially change the pumping characteristics of the unit.

PACKING USED AND GLAND CONSTRUCTION

Several types of glands are used on LaBour pumps, together with several kinds of packing, depending upon the liquid to be handled. The gland on a pump which handles corrosive liquid must be intelligently operated and maintained in order that satisfactory results may be obtained.

This packing is thoroughly impregnated with special grease and graphite. Pumps handling caustic have a special packing for this service, while pumps on hydraulic duty are packed with a good grade of hydraulic packing. When repacking a pump, care must be taken to use the correct size and kind of packing for the particular service.

The most common gland used with LaBour pumps is of the floating type with a double packing seal. In this construction, the main packing is within a projection on the pump back and is compressed through an external auxiliary gland which also carries packing. The entire assembly is compressed through a gland follower by means of some compression device such as gland bolts.

An extra deep stuffing box is provided for certain services. This type generally has a lantern ring located in the center of the single packing chamber. This ring communicates with a passage in the projection on the pump back which in turn allows grease to be forced to this lantern ring, or allows a liquid seal to be used.

REPACKING GLAND

When it becomes necessary to repack the gland, the pressure on the gland follower should be entirely released. The gland and gland follower can then be slid back along the shaft and the packing removed from both the main and the auxiliary chambers. New packing should be cut to such length that when the ends are butted together a ring will be formed which is of slightly larger diameter than the packing chamber. When this ring is forced into place the ends will be held tightly together. Care must be taken to stagger the joints. After a gland has been packed, it should be carefully watched and in some cases an extra ring of packing may be inserted after

a short period of operation.

In repacking a deep stuffing box, care must be taken that the lantern ring is in the center of the packing chamber when the gland is compressed. The lantern ring communicates with a grease or liquid passage in the packing chamber, and if the lantern ring is not in the approximate center of this chamber, the grease or liquid cannot flow to this ring.

WATER COOLED HUBS AND WATER SEALED GLANDS

When pumping hot liquids it is desirable to keep the gland temperature as low as possible, thus preserving the life of the packing. For this service, a pump with a water-cooled gland should be used. In this design, an annular water chamber is cored in the casting which surrounds the packing. LaBour pumps provide optional water cooling. It is only necessary to add pipe connections to make use of this feature.

Pumps operating with vacuum on the suction may be provided with liquid sealed glands, which design prevents an excessive amount of air being drawn past the gland. Water-sealing cannot be used with concentrated sulphuric acid and with some other liquids under certain conditions.

REPAIRING THE PUMP

All rotating parts are contained in a single assembly, which may be removed or replaced as a unit without disturbing pipe connections or motor and without affecting alignment. The pictures and explanation on the opposite page show the simplicity of this operation. Liquid ends are dimensionally interchangeable, so that different materials of construction may be substituted when needed. If desired, an entire new drive unit with impeller may be quickly installed, permitting prompt resumption of service while repairs are being made.

DIRECTIONS FOR LOCKING SEPARABLE IMPELLER SCREW

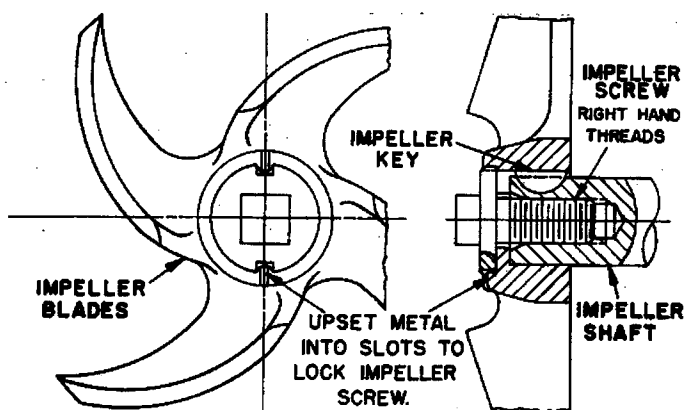

GIVE PART NUMBER AND PUMP SERIAL NUMBER WHEN ORDERING REPAIRS

When reassembling a pump, care must be taken that when the impeller is firmly seated in position there is a clearance of approximately $\frac{1}{32}$ " between the impeller blades and the pump back. When the pump casing is in position, the entire assembly is so designed that there will not be less than $\frac{1}{32}$ " between the impeller blades and the pump casing. The clearances are all obtained through the use of a $\frac{1}{16}$ " thick casing gasket. The use of a thinner gasket will reduce the clearance and the use of a thicker gasket will mean excessive clearance between the impeller and the pump casing. Because of the high co-efficient of expansion of chrome alloys, impellers made of such metals are set closer to the pump back than to the casing.

The bearing bracket is provided with two ball

bearings which carry the drive shaft.

If it should become necessary to replace a ball bearing, the present bearing should be pressed off the shaft. The new bearing should be heated in oil to a temperature of 300° F., at which temperature it can be slipped over the shaft and drawn snugly into place by the locknut which is secured by the lock washer.

If it becomes necessary to replace the oil seals or reassemble the end covers in the QC bracket assembly, care must be used not to cut or notch the lip of the seal when pushing it on the shaft as this may cause leakage. The best method is to use a coned assembly cap on the ends of the drive shaft. This will protect the seal from possible damage from prying tools, sharp edges, or keyways. (See drawing below.)

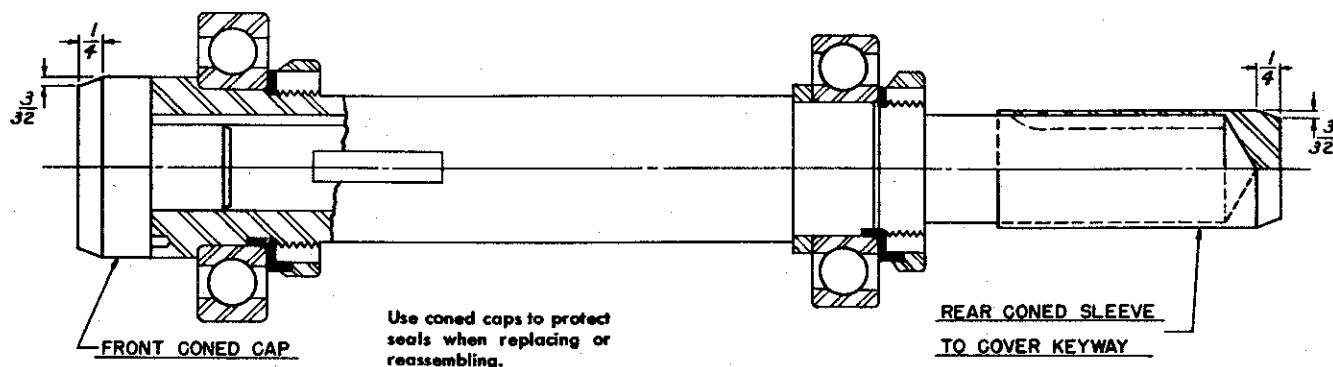

OPERATING INFORMATION

If pump requires too much power, the following possible causes should be checked:

- A. Dynamic head materially lower than that specified. This will usually increase the capacity and power required.
- B. Specific gravity of liquid higher than that for which the pump was powered. The power varies directly as the specific gravity.
- C. Viscosity of the liquid too high.
- D. Mechanical damage, such as impeller rubbing.
- E. Scale deposits or other obstructions inside of pump casing and in contact with rotating parts.
- F. Mechanical or adjustment defects in the prime mover or power supply, resulting in a lower output and an apparatus over-load.

GIVE PART NUMBER AND PUMP SERIAL NUMBER WHEN ORDERING REPAIRS

TYPE "SZ" PUMP (WITH SPACER COUPLING)

PUMP NO.	SUCTION	DISCHARGE			TOLERANCE			BASE	D	E	F	G	H	I	J	K	L	M	N	P	Q
		A	B	C	1/16	1/8	1/4														
10	1 1/2	6	3 1/16	2 3/16	182	184	18-5-3	9/8	3 13/16	3 3/16	3 3/4	36	44	2 1/2	2 1/4	1 5/16	5 1/4	18 5/16	4		
12	2	1 1/2	6 1/16	3 13/16	2 3/8	182	184	18-5-3	9/8	4	3 3/4	36	44	2 1/2	2 1/4	1 5/16	5 1/4	18 5/16	4		
14	2	1 1/2	6 7/8	4 5/16	2 3/2	213	215	18-5-1	9/8	4 3/16	3 3/4	36	44	2 1/2	2 1/4	1 5/16	6 1/4	18 5/16	4		
15	2 1/2	2	7 1/2	4 3/4	3 1/8	254U-256U	28-5-4	10 7/8	5 1/16	3 3/4	3 3/4	36	44	2 1/2	2 1/4	1 5/16	6 1/4	18 1/8	4		
20	3	2 1/2	8 5/8	5 7/16	3	284U-286U	28-5-4	10 7/8	3 13/16	6 3/4	6 3/4	48	56	3 3/16	3 5/8	2 3/16	8	20 7/16	4		
30	4	3	9 1/4	6 7/16	3 3/4	324U-326U	28-5-2	11 7/8	5 1/16	6 3/4	6 3/4	48	56	3 3/16	3 5/8	2 3/16	8	20 7/16	4		

⊗ NOMINAL

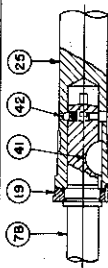

* ALTERNATE SEPARABLE SHAFT CONSTRUCTION

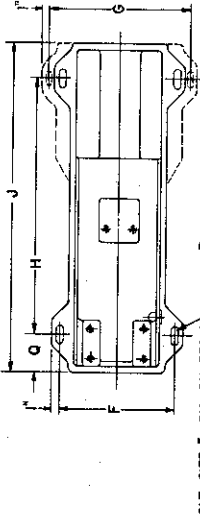

BOLT SIZE 3/8" DIA. ON 350-S
1/2" DIA. ON ALL OTHERS

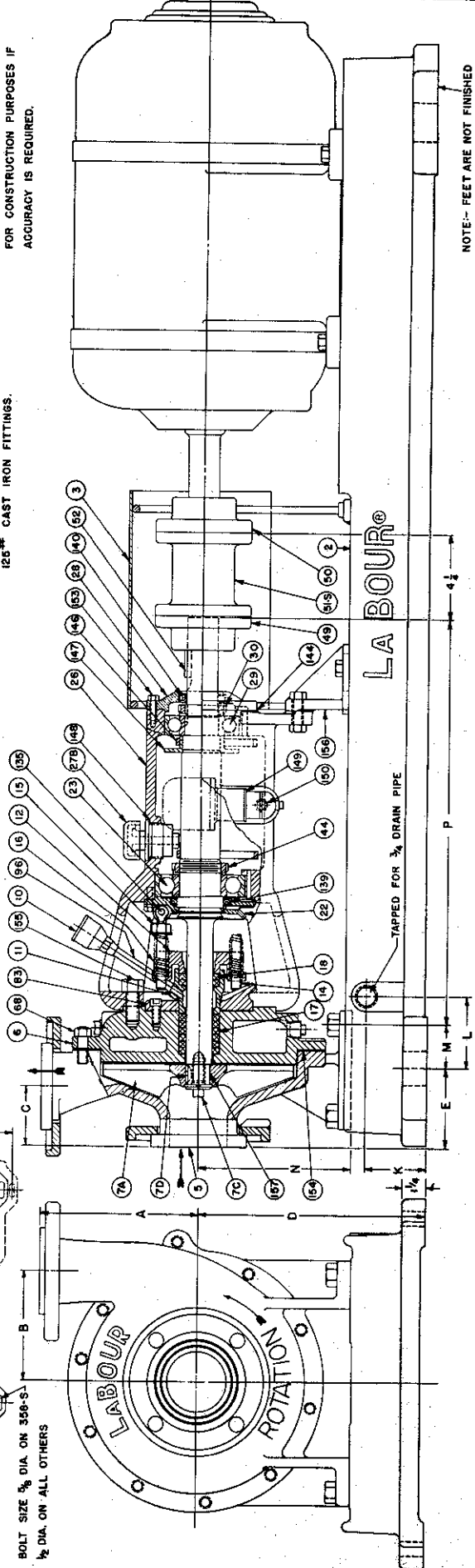

NOTE:- FEET ARE NOT FINISHED EXCEPT ON SPECIAL ORDER. IF FINISH IS DESIRED 1/16" MUST BE SUBTRACTED FROM "O".

NOTE:- THIS FORM FOR REFERENCE PURPOSE ONLY AND IS NOT CERTIFIED FOR CONSTRUCTION DETAILS OR DIMENSIONS.

PC NO.	NO. RECD	NAME OF PART	PC NO.	NO. RECD	NAME OF PART
1	44	BASE PLATE	1	44	FRONT BEARING LOCKNUT & WASHER
2	45	COUPLING GUARD	2	45	FLEXIBLE COUPLING (PUMP HALF)
3	46	PUMP CASING	3	46	FLEXIBLE COUPLING (MOTOR HALF)
4	47	PUMP BACK	4	47	FLEXIBLE COUPLING SPACER
5	48	IMPELLER SHAFT	5	48	FLEXIBLE COUPLING KEY
6	49	IMPELLER KEY	6	49	CASING STUDS & NUTS (#10 PUMP)
7A	50	IMPELLER SCREW	7	50	CASING STUDS & NUTS (#12 PUMP)
7B	51	IMPELLER SCREW	8	51	CASING STUDS & NUTS (#14 & 18 PUMP)
7C	52	IMPELLER SCREW	9	52	CASING STUDS & NUTS (#20 & 30 PUMP)
7D	53	IMPELLER SCREW	10	53	HUB COVER
10	54	GREASE CUP	11	54	1/8" PIPE NIPPLE
11	55	GLAND FOLLOWER	12	55	EYE BOLT PIN
12	56	EYE BOLT	13	56	3" DRILL DRIFT
14	57	HEX NUT	14	57	FRONT OIL SEAL
15	58	HEX NUT	15	58	FRONT OIL SEAL
16	59	SPRING	16	59	FRONT OIL SEAL
17	60	INNER PACKING	17	60	FRONT OIL SEAL
18	61	OUTER PACKING	18	61	FRONT OIL SEAL
19	62	SLINGER "O" RING & PIN	19	62	FRONT OIL SEAL
22	63	FRONT BEARING COVER	22	63	GASKET
23	64	FRONT BEARING	23	64	OIL RING
25	65	DRIVE SHAFT	25	65	OIL RING GUIDE
26	66	BEARING BRACKET	26	66	GASKET
27B	67	BREATHER PLUG	27	67	CONSTANT LEVEL OILER
28	68	REAR BEARING COVER	28	68	1/4" X 1 1/2" PIPE NIPPLE
29	69	REAR BEARING	29	69	HEX CAP SCREWS
30	70	REAR BEARING LOCKNUT & WASHER	30	70	GASKET
41	71	DRIVE KEY	41	71	HEX CAP SCREWS
42	72	SOCKET LOCKSCREW	42	72	SUPPORT BRACKET
			43	73	1" STD. THRU SHAFT

NOTE:- UNLESS CERTIFIED DIMENSIONS AS GIVEN ARE NOMINAL ONLY AND NOT INTENDED FOR CONSTRUCTION PURPOSES IF ACCURACY IS REQUIRED.

NOTE:- DIAMETERS AND DRILLINGS OF FLANGES ARE ACCORDING TO STANDARDS FOR 125# CAST IRON FITTINGS.

TYPE "SQ" PUMP (WITH SPACER COUPLING)

PUMP NO.	SUCTION	DISCHARGE	TOLERANCE															
			A	B	C	D	E	F	G	H	J	K	L	M	N	P	Q	
15	2 1/2	2 1/2	6 1/2	5 3/8	4 3/8	1 1/8	4	16 3/4	16 3/4	48	56	3 3/8	3 5/8	2 3/16	8	18 5/16	4	
			13 1/2	12 1/2	18 3/4	18 3/4	53	61	3	4 7/8	3 3/4	8	19	4				
			25 1/4	24 1/2	16 3/4	16 3/4	48	56	3 3/8	3 5/8	2 3/16	8	19	4				
			32 1/4	31 1/2	18 3/4	18 3/4	53	61	3	4 7/8	3 3/4	8	19	4				
20	3	3	7	6	4 3/4	3 1/8	3 1/8	18 3/4	18 3/4	53	61	3	4 7/8	3 3/4	10	2 1/4	4	
			14 1/2	14 1/2	16 3/4	16 3/4	48	56	3 3/8	3 5/8	2 3/16	8	19	4				
			28 1/2	28 1/2	18 3/4	18 3/4	53	61	3	4 7/8	3 3/4	8	19	4				
			36 1/2	36 1/2	19 3/4	19 3/4	64	72	3 1/2	4 1/8	3 1/4	10	2 1/4	4				
35	4	4	8 1/4	7	4 1/4	4 1/2	18 3/4	18 3/4	53	61	3	4 7/8	3 3/4	11 3/4	2 1/4	4		
			15 1/2	15 1/2	16 3/4	16 3/4	48	56	3 3/8	3 5/8	2 3/16	8	19	4				
			30 1/2	30 1/2	18 3/4	18 3/4	53	61	3	4 7/8	3 3/4	8	19	4				
			38 1/2	38 1/2	19 3/4	19 3/4	64	72	3 1/2	4 1/8	3 1/4	10	2 1/4	4				
45	6	4	8 3/4	7 5/8	4 3/4	4 1/2	18 3/4	18 3/4	53	61	3	4 7/8	3 3/4	11 3/4	2 1/4	4		
			15 1/2	15 1/2	16 3/4	16 3/4	48	56	3 3/8	3 5/8	2 3/16	8	19	4				
			30 1/2	30 1/2	18 3/4	18 3/4	53	61	3	4 7/8	3 3/4	8	19	4				
			38 1/2	38 1/2	19 3/4	19 3/4	64	72	3 1/2	4 1/8	3 1/4	10	2 1/4	4				
55	6	6	10	7 1/6	5 7/8	5 7/16	18 3/4	18 3/4	53	61	3	4 7/8	3 3/4	11 3/4	2 1/4	4		
			15 1/2	15 1/2	16 3/4	16 3/4	48	56	3 3/8	3 5/8	2 3/16	8	19	4				
			30 1/2	30 1/2	18 3/4	18 3/4	53	61	3	4 7/8	3 3/4	8	19	4				
			38 1/2	38 1/2	19 3/4	19 3/4	64	72	3 1/2	4 1/8	3 1/4	10	2 1/4	4				

⊗ NOMINAL

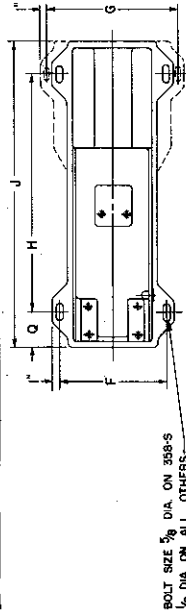
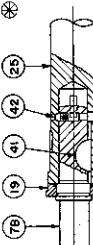

BOLT SIZE 5/8" DIA. ON 338-S
1/2" DIA. ON ALL OTHERS

P.C. NO. NO. RECD.	NAME OF PART	P.C. NO. NO. RECD.	NAME OF PART
2	BASE PLATE	44	FRONT BEARING LOCKNUT & WASHER
3	COUPLING GUARD	45	FLEXIBLE COUPLING (PUMP HALF)
5	PUMP CASING	50	FLEXIBLE COUPLING (MOTOR HALF)
6	PUMP BACK	51-5	FLEXIBLE COUPLING SPACER
7A	IMPELLER SHAFT	52	FLEXIBLE COUPLING KEY
7B	IMPELLER SCREW	68	CASING STUDS & NUTS (#15 PUMP)
7C	IMPELLER KEY	68	CASING STUDS & NUTS (#35 PUMP)
10	GREASE CUP	68	CASING STUDS & NUTS (#45 & 55 PUMP)
11	GLAND	83	HUB COVER
12	GLAND FOLLOWER	96	1/8" PIPE NIPPLE
14	EYE BOLT	135	2" EYE BOLT PIN
15	HEX. NUT	136	2" DRILL DRIFT
16	SPRING	139	2" PLY BAR
17	INNER PACKING	140	FRONT OIL SEAL
18	OUTER PACKING	140	REAR OIL SEAL
19	SLINGER "O" RING & PIN	144	2" GASKET
22	FRONT BEARING COVER	147	2" OIL RINGS
23	FRONT BEARING	148	2" GASKET
24	DRIVE SHAFT	149	1" CONSTANT LEVEL OILER
25	BEARING BRACKET	150	1/4" X 1 1/2" PIPE NIPPLE
27A	BREATHER PLUG	150	1/4" X 1 1/2" PIPE NIPPLE
28	REAR BEARING COVER	153	8" HEX. CAP SCREWS
29	REAR BEARING	154	2" GASKET
30	REAR BEARING LOCKNUT & WASHER	155	4" HEX. CAP SCREWS
31	DRIVE KEY	156	1" SUPPORT BRACKET
41	DRIVE KEY	156	1" SUPPORT BRACKET
42	SOCKET LOCKSCREW	157	1" STD. THRU SHAFT

NOTE:-
DIAMETERS AND DRILLINGS OF FLANGES ARE ACCORDING TO STANDARDS FOR 125# CAST IRON FITTINGS.

NOTE:-
UNLESS CERTIFIED DIMENSIONS AS GIVEN ARE NOMINAL ONLY AND NOT INTENDED FOR CONSTRUCTION PURPOSES IF ACCURACY IS REQUIRED.

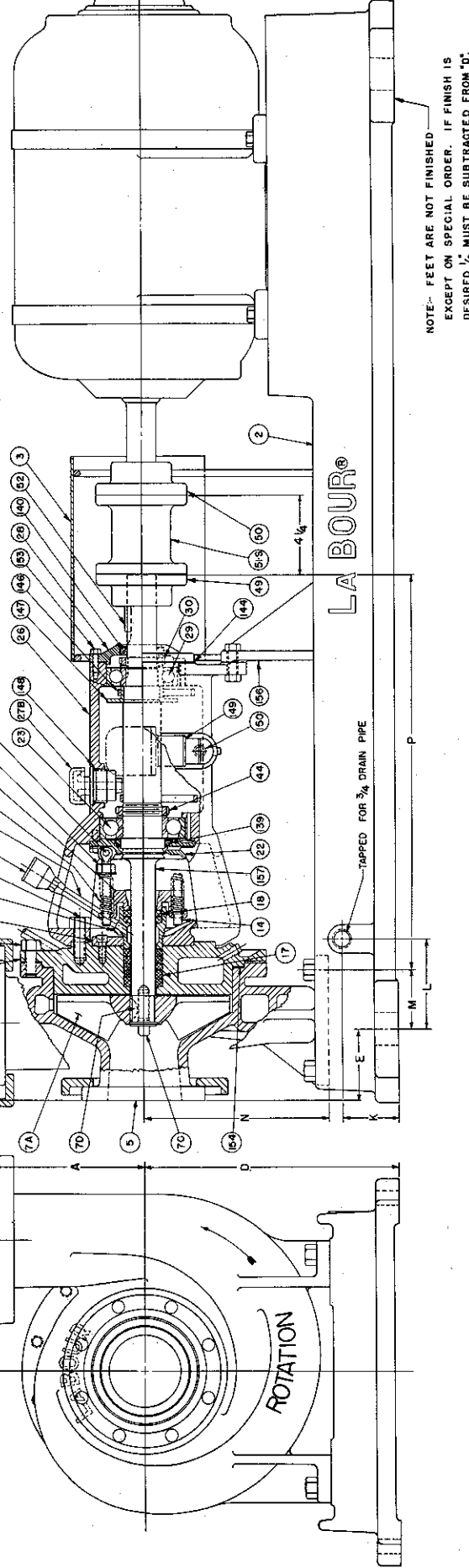

NOTE:- THIS FORM FOR REFERENCE PURPOSE ONLY AND IS NOT CERTIFIED FOR CONSTRUCTION DETAILS OR DIMENSIONS.



LaBour, Taber Pumps are product lines of Peerless Pump Company
P. O. Box 7026 Indianapolis, Indiana 46207-7026
Ph. (317) 925-9661 Fax. (317) 920-6605
www.labourtaber.com