

REPAIR INSTRUCTIONS

8TUTF15 PACKED

READ THIS ENTIRE BULLETIN

before attempting to repair this pump. For installation and operation refer to instruction bulletin 2880549. Properly installed, your Peerless pump will give you satisfactory, dependable service. We urge that you carefully read these step-by-step instructions, to simplify any problems of installation, operation or repair.

Failure to read and comply with installation and operating instructions will void the responsibility of the manufacturer and may also result in bodily injury as well as property damage.

This bulletin is intended to be a permanent part of your pump installation and should be preserved in a convenient location for ready reference. If these instructions should become soiled, obtain a new copy from Peerless Pump. Include pump model and/or serial number with your request.

These instructions are prepared for pumps with grease lubricated bearings and packed stuffing boxes.

When ordering repair parts, provide the complete model number and the pumps serial number; both are stamped on the pump nameplate.



Peerless Pump Company
2005 Dr. Martin Luther King Jr. Street
Indianapolis, IN 46202
Phone: (317) 925-9661 • Fax: (317) 924-7388

Sterling Fluid System (USA), Inc.

2959694

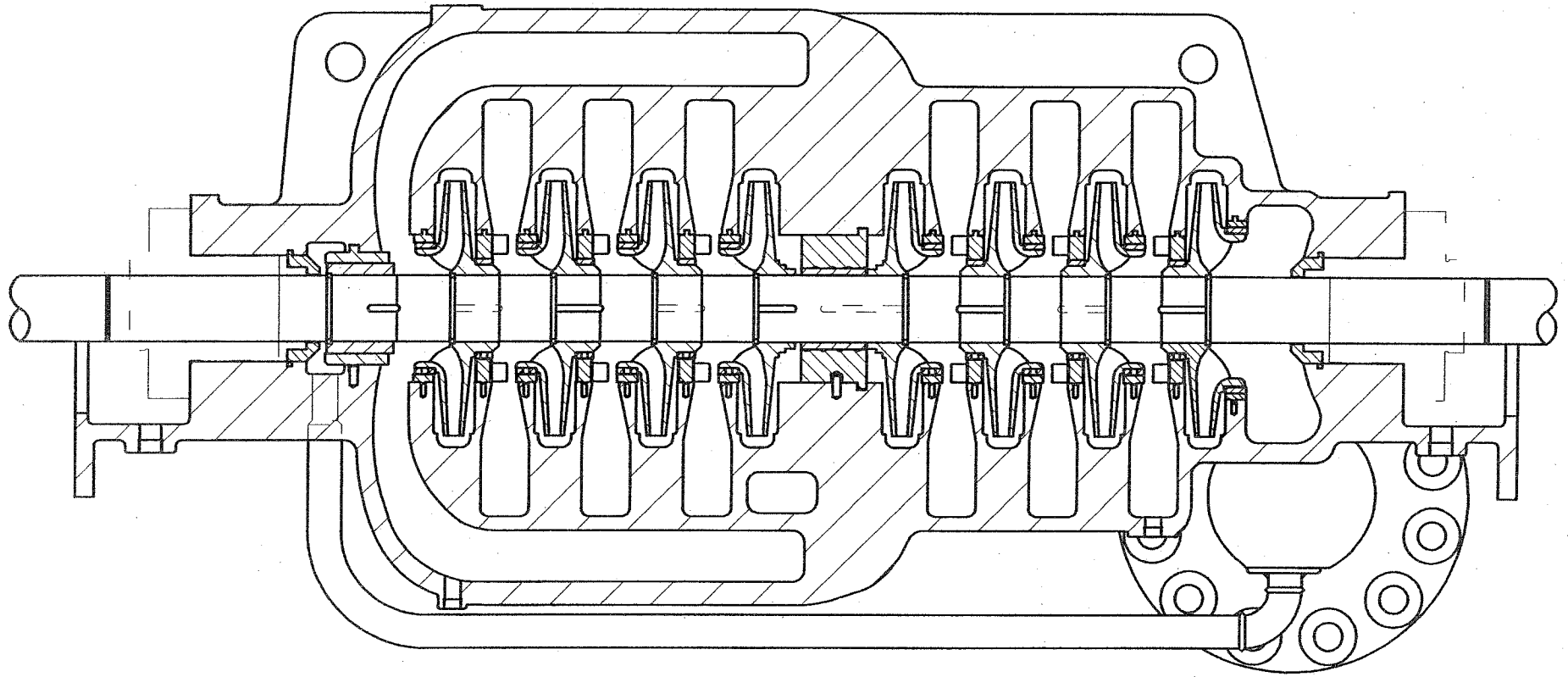

TYPICAL PUMP CROSS SECTION



Sterling Fluid System (USA), Inc.

8TUTF15

REPAIR BULLETIN

SUBJECT: MAINTENANCE

1.0 SCOPE

General instructions to direct a safe and efficient maintenance project.

This section will be followed by additional sections dealing with specific and detailed instructions addressing each major assembly.

2.0 RECORDS AND ANALYSIS

- 2.1 **Performance Record** An ongoing performance record will assist troubleshooting and pump service decisions. Long shutdowns and unnecessary expense can be avoided.

Pressure indicators can be installed into tapped openings in the suction and discharge nozzles to provide much of the data required for performance analysis.

Periodic vibration recordings are necessary to diagnose excessive vibration levels.

- 2.2 **Troubleshooting** Analyze performance before disassembly. A problem could be corrected externally without disassembling the pump. A performance record will help narrow the possible causes, and determine whether the problem is mechanical or hydraulic.

Hydraulic problems typically originate in the suction system. Control misadjustments should be eliminated. See OPERATION Section before further troubleshooting.

Mechanical and hydraulic problems often are interrelated and the source can be difficult to trace. See TROUBLESHOOTING Addendum No. 4 at the end of this section.

3.0 GENERAL DISASSEMBLY

- 3.1 **References** Refer to specific general arrangement drawings, cross section drawings and parts list.
- 3.2 **Power** Lock power breakers to off position.
- 3.3 **Piping** Be certain pump system pressure has been isolated. Close all suction, discharge, and auxiliary piping valves.
- 3.4 **Coupling** Remove both the coupling spacer, between the pump and driver hubs, and the pump coupling hub.



Sterling Fluid System (USA), Inc.

STUTF15

REPAIR BULLETIN

SUBJECT: CASE / ELEMENT ASSEMBLY

1.0 SCOPE

Directions for the disassembly, inspection of parts and reassembly of the rotating element including the opening and closing of the volute case.

2.0 PREPARATION

Study the Pump Cross-Section drawing and be familiar with the design details and assembly sequence.

Phase the operations and have equipment available for impeller/shaft sleeve mounting and dismounting, and also measuring devices, heating facilities and a torque wrench for case bolting.

Be familiar with the heating temperatures, mounting and dismounting forces and torque values.

3.0 EXAMINATION AND CLEANLINESS

Unless the volute case needs renovation, the bottom half will remain installed after the top half has been dismantled and the rotating element removed.

The case halves must be protected from the ingress of dirt and physical damage during the maintenance cycle. The rotating element must be removed to a clean work area for disassembly.

Some preliminary examination and assessment of the extent of the work can be made when the volute case top half is lifted. More detailed inspection of part size and condition must be made after element disassembly.

4.0 CASE TOP HALF REMOVAL

It is assumed that all items of maintenance described in the **MAINTENANCE** Section of this manual have been completed.

- 4.1 Disconnect and remove sections of piping that will interfere with the top half removal. Cap piping ends to prevent dirt entry.
- 4.2 Install spacers between the mechanical seal sleeve drive collars and the gland plates, then loosen drive collar screws.
- 4.3 Loosen and back-off mechanical seal gland nuts at each end. Free gland plates from case gland faces but leave mechanical seals in place.



Sterling Fluid System (USA), Inc.

STUTF15

REPAIR BULLETIN

SUBJECT: MAINTENANCE

3.0 GENERAL DISASSEMBLY (Cont'd.)

3.5 **Drain** Open the vents and drain the pump case by removing the drain plugs or opening the valves.

Warning: Check for toxic or otherwise harmful fluids before loosening bolted joints or pipe connections.

3.6 **Tools and Procedures** A variety of equipment is required for disassembly. Refer to each assembly section for specific requirements.

Caution: Check pump rotation. Note that certain threaded shaft components are tightened against rotation and may be left-hand thread.

4.0 MECHANICAL SEAL CHANGEOUT

The mechanical seal can be removed for inspection and replacement without disturbing the case. Removal of auxiliary piping, bearings, bearing housings, spacer coupling, and pump coupling hub is required. See also BEARING ASSEMBLY Section.

Be sure to follow the Seal Manufacturer's maintenance instructions. See Seal Manufacturer's drawing for correct assembly and disassembly procedures, materials, and seal setting. New O-rings, springs, and faces (if necessary) should be installed when the seal is serviced.

5.0 PREPARATION FOR MAJOR DISASSEMBLY

This outlines the sequence of disassembly and indicates the extent of work necessary to deal with key components.

5.1 **Bearings, Mechanical Seals** The bearings, bearing housings and mechanical seals must be removed before pulling the rotating element. See BEARING ASSEMBLY Section for details

5.2 **Rotating Element.** The case top half is removed and the rotating element lifted from the case bottom half.

5.3 **Inspection** Inspection of many of the rotating element components can be done without disassembly. This "surface" inspection, or a previously-noted performance deficiency from the performance record, can provide the need for further disassembly and inspection.



STUTF15

REPAIR BULLETIN

Sterling Fluid System (USA), Inc.

SUBJECT: CASE / ELEMENT ASSEMBLY

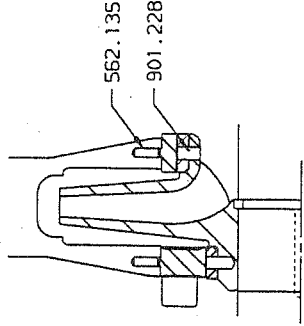
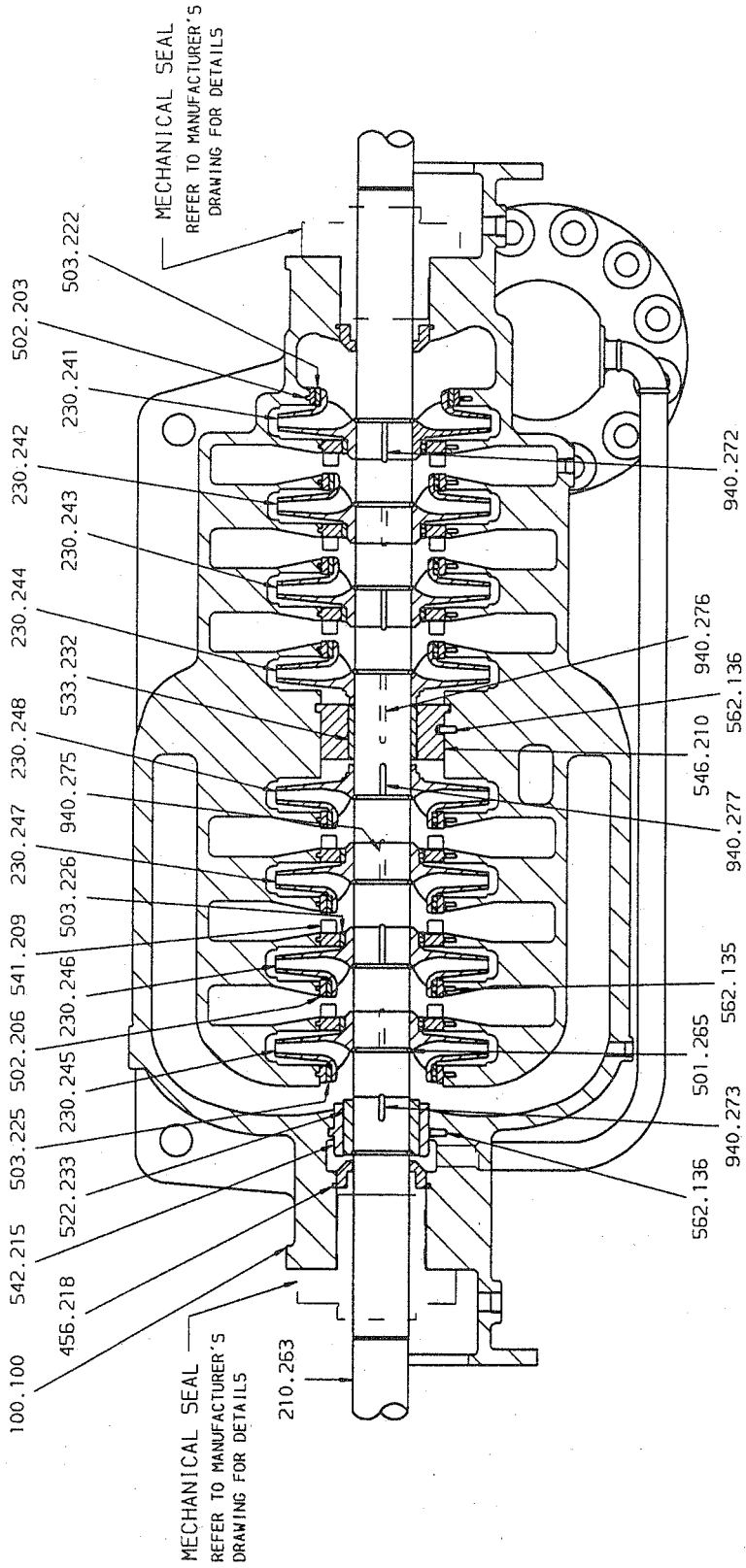

8TUTF15

REPAIR BULLETIN

SUBJECT: CASE / ELEMENT ASSEMBLY

- 4.4 Check total axial movement of the element in the case (Endo) and record for use at re-assembly.
- 4.5 Remove case taper pins and cap nuts from split line studs.
- 4.6 Rig chains to the two case lifting points; use the four jackscrews to break the joint and lift the top half casing vertically to clear the rotating element.
- 4.7 The split line face of both halves of the case and the case studs which are now exposed must be protected from corrosion or physical damage.

5.0 ELEMENT REMOVAL AND DISASSEMBLY

Without further disassembly, a fairly extensive visual examination of the pump parts can be made. At this point, it will be determined whether element removal is necessary.

Proceed as follows to remove rotating element:

- 5.1 Remove bearing assemblies as described in the **BEARING ASSEMBLY** Section of this manual.
- 5.2 Remove nuts from studs and slide the mechanical seals from shaft. Clean and store mechanical seals in accordance with manufacturers instructions ready for re-use.
- 5.3 Rig rope slings around the shaft and lift the rotating element without using excessive force. If the case rings and bushings bind in the case grooves, careful use of a pry bar at each location will help free them.
- 5.4 If the element is to be transported, it should rest in a cradle with solid supports at each end and at the center.
- 5.5 In a clean work area, disassembly can proceed by removing the throat bushings **456.218**, the throttle bushing **542.215**, the center bushing **546.210** and the case rings **502.203** and **502.206** from both ends of the element.
- 5.6 Further disassembly requires the removal of impellers and sleeves that were shrunk on to the shaft.

Caution: It must be emphasized that successful results using the following process requires experience or first hand advise from a Peerless Pump representative. The components must be heated and permanent damage can result if the level and duration of heating is not properly controlled.

8TUTF15

REPAIR BULLETIN

Sterling Fluid System (USA), Inc.

SUBJECT: CASE / ELEMENT ASSEMBLY

- 5.7 The impeller bores and corresponding shaft fits are different diameters at each location.

Before dismantling, clearly diagram the element making note of the number marked on each impeller and its position on the shaft.

- 5.8 Clamp one end of the shaft in a vice using soft jaws. Clamp at the shaft section that carries the mechanical seal not on the bearing journals.

The free end of the shaft must rest in a steady rest with 3 or 4 impellers outboard of the steady rest ready for removal.

- 5.9 The throttle sleeve **522.233** and each impeller **230.241** through **230.254** is secured axially with a split ring **501.265** encapsulated in the bore of the secured part.

Caution: During the heating and removal process, the throttle sleeve and each impeller must be pushed back to remove the split ring then withdrawn from the shaft.

- 5.10 Clean off any deposit ahead or behind the part to be removed using a non-abrasive metal cleaner.

- 5.11 For heating, use a gas torch fitted with a 1" - 2" heating rosebud. Do not use a cutting torch.

- 5.12 Before starting, make sure 2 people are available, each person understanding their assigned tasks for the removal process and properly equipped.

- 5.13 Heat part evenly, all around and from the outside to the inside, spending proportionally more time on the impeller hub. 2 minutes of elapsed time is normally sufficient.

- 5.14 The person not holding the torch must free the part, grasping with gloved hands to pull back, remove the split ring and withdraw part from the shaft.

Note: Tapping with a mallet may facilitate removal but take care not to damage the impeller shrouds in the process.

Caution: Take care not to allow too much heat to soak into the shaft. If significantly more than 2 minutes elapsed during the heating cycle, stop heating, allow to cool completely and start again.

If problems persist, contact a Peerless Pump representative.



Sterling Fluid System (USA), Inc.

STUTF15

REPAIR BULLETIN

SUBJECT: CASE / ELEMENT ASSEMBLY

5.15 As the sleeve or impeller is removed, the drive key can be lifted from its keyseat and the shaft allowed to cool.

Note: At this time check for a snap ring at the back of the impeller seating surface and remove.

A snap ring is added as an option to secure impeller against reverse axial movement.

5.16 A stationary ring 502.206 and an interstage bushing 541.209 can be removed with the removal of each impeller.

5.17 To remove the impeller wear rings 503.222, 503.225 and 503.226, first remove the 3 to 8 radial screws securing the rings to the impeller.

5.18 With the radial screws removed, a ring puller can be applied to the edge of the wear ring adjacent to the impeller shroud to remove the ring.

6.0 VOLUTE CASE INSPECTION

Before installation of the element into the volute case, the volute case must be inspected for flatness on the case parting flange, both top and bottom halves, and the bore must be checked for size.

6.1 Case Parting Flange Flatness

Obtain a precision straightedge that will cover the length and width of the pump case parting flange. Obtain a set of feeler gauges.

First, choose one end of either the top or bottom case half and lay the straightedge across the width (parallel to the suction/discharge nozzles) at either end right over the stuffing box bore.

8TUTF15

REPAIR BULLETIN

SUBJECT: CASE / ELEMENT ASSEMBLY

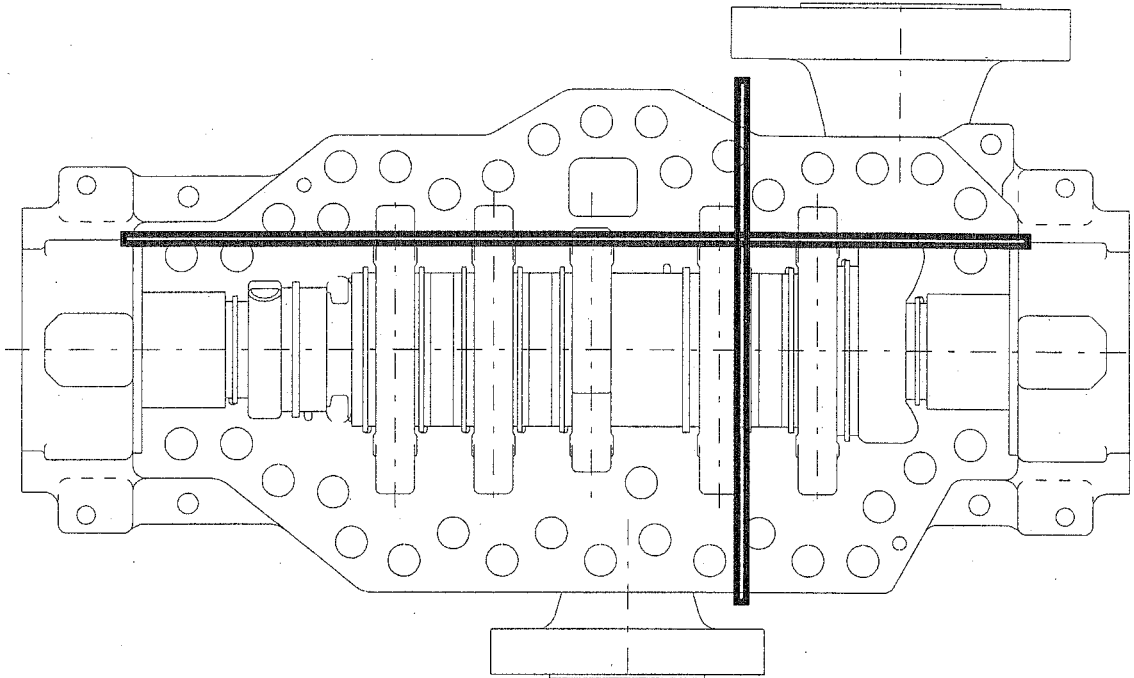

Attempt to slide a .002 inch feeler gauge underneath the straightedge measuring at every point that it covers the case. .002 or less is the maximum gap allowed. If .003" feeler gauge or above will slide underneath the straightedge, the case must be rejected for non-flatness. Contact a Peerless Pump representative for instructions. If the readings are acceptable, move the straightedge down the case half, positioning it over every running fit in the bore and repeat the above procedure. Likewise, repeat the procedure for the other case half.

Note: On the bottom half, position the straightedge so that studs do not have to be removed.

6.2 Bore Check for Size

Note: Using stationary wear parts as templates.

From the spare parts, obtain one of each of the following:
Series Stationary Ring, First Stage Stationary Ring, Throttle Bushing,
and the Center Bushing.

STUTF15

REPAIR BULLETIN

SUBJECT: CASE / ELEMENT ASSEMBLY

- 6.2.1 Using the series stationary ring, first position it in all the series ring and interstage bushing fits. The ring should go all the way down in the fit and over the anti-rotation pin without binding. Rotate the ring back and forth to make sure the ring is engaging the anti-rotation pin. This should be a close registration fit just loose enough for freedom of movement - **not tight**. If the ring locates on the fit but is tight, the case fit can be hand scraped using tool steel to achieve this freedom of movement. If the ring will not even sit down on the fit, the case must be removed for remachining. If the ring locates on the fit and is loose such that it can be rocked back and forth, the pump case must be removed for remachining.

Repeat this procedure using the other pieces in their corresponding fits. Use the same acceptance criteria as above.

Note: While measuring, do not overlook the area within 1" (25 mm) of the edge of the bore. If the pump has been through a seizure, this area is most likely to be distorted, and is the most critical area for sealing the split line.

- 6.2.2 Upon acceptance of 6.2.1, lay the straightedge along the length (perpendicular to suction/discharge nozzles) of the volute case half starting just even with the knife edge of the bore. Measure for flatness using the procedure and acceptance criteria of 6.1 above. Next, move the straightedge out away from the bore in 2 or more equal spacings. Measure for flatness on every move of the straightedge. When complete, move the straightedge to the other side of the bore and measure for flatness following the same procedure as before. Repeat the same procedure for both case halves.

8TUTF15

REPAIR BULLETIN

Sterling Fluid System (USA), Inc.

SUBJECT: CASE / ELEMENT ASSEMBLY

7.0 INSPECTION OF OTHER PARTS

- 7.1 **Clean and Inspect** After disassembly, clean the parts and inspect for wear or damage, in particular the running surfaces of all rings, sleeves and bushings.

Damaged or excessively worn parts should be discarded. Reusable parts should be prepared for short term storage by applying a light machine oil to all machined surfaces.

- 7.2 **Mechanical Seal** As the mechanical seals are removed, they should be immediately cleaned and stored in accordance with the manufacturers instructions.

- 7.3 **Bearings** Refer to the bearing assembly instructions in the **BEARING ASSEMBLY** Section of this manual for special handling.

- 7.4 **Impellers** Inspect impellers for wear or damage. Look for cavitation marks (pits) in the suction opening, erosion of vanes, and cracks in the shroud. Major damage should signal replacement. Minor irregularities can be smoothed and foreign material should be removed, but take care not to degrade the impeller bore.

- 7.5 **Wear Rings, Sleeves and Bushings** Inspect these parts for grooves and uneven wear. Dress minor irregularities and remove any foreign material.

Measure bores and outside diameters of the running surfaces to determine the diametrical clearance in each case.

A clearance of no greater than 140% of the original design must still exist over at least 85% of the surface to make the parts reusable.

The remaining surface must not vary by more than .002 inches on the diameter.

- 7.6 **Shaft** Clean the shaft of any scale or deposit as far as possible using an effective method that will not further degrade fits and surface finish.

Support the shaft at the radial bearing locations and check the runout at the impeller and mechanical seal locations. The TIR must be within the limits indicated in paragraph 8.17.

Measure the shaft diameter at each impeller mounting surface and the corresponding impeller bore to ensure that shrink fits have been maintained. Check with a Peerless Pump representative for further details.

If the shaft is to be stored for re-use, it should be lightly oiled, covered with a protective sleeve and if possible, hung vertically to maintain straightness.

8TUTF15

REPAIR BULLETIN

Sterling Fluid System (USA), Inc.

SUBJECT: CASE / ELEMENT ASSEMBLY

8.0 ELEMENT ASSEMBLY

It is recommended that minor parts in the assembly be replaced. These would include impeller keys, split rings and pins.

Parts salvaged from the original assembly will have been examined and prepared for reassembly during the inspection cycle. Replacement parts should be on hand having been checked at receipt for correctness for assembly.

8.1 To install impeller rings (chamfered inside edge to impeller) 503.222, 503.225 and 503.226 on the impellers 230.241 through 230.254, heat rings in an electric oven to 400°F. No other process is acceptable.

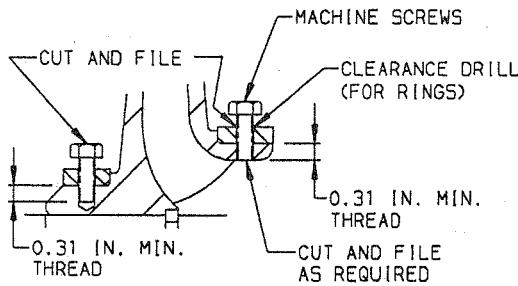

For rings wider than .750 inches		
Ring Dia OD, in.	Capscrews AISI 316 material qty & size, in.	Tap Drill size, (in.)
to 6.50	3 of .250-28 UNF x .75 long	"3" drill (.213)
6.51-10.00	6 of .250-28 UNF x .75 long	"3" drill (.213)
10.01-15.00	6 of .312-18 UNC x 1.00 long	"F" drill (.257)
15.01-up	6 of .375-24 UNF x 1.00 long	"Q" drill (.332)
For rings ≤ .750 inches (API 610 7th Edition)		
to 6.50	4 of #12-24 UNC x .75 long	"16" drill (.177)
6.51-10.00	8 of #12-24 UNC x .75 long	"16" drill (.177)

LOCKING SCREW AND TAP DRILL SIZE CHART

8.2 Install rings so that the locking screw holes do not align with old holes, keyway, or impeller vanes. Check that installed rings contact the impeller shoulder circumference.

8.3 Drill new locking screw holes into the impeller, using ring holes as a guide. See **LOCKING SCREW AND TAP DRILL SIZE CHART**. Be careful not to drill through shroud, unless metal thickness does not allow .31 inches of minimum thread depth without drilling on through. Control drilling depth by use of a drill stop.

8.4 Tap threads, leaving imperfect threads at the bottom so screws will bind to lock.

Note Metal thickness at the impeller shroud may not allow .31 inches minimum thread depth without drilling on through. Tap the threads on through and reach in with a punch to create two imperfect threads at the bottom.

STUTF15

REPAIR BULLETIN

Sterling Fluid System (USA), Inc.

SUBJECT: CASE / ELEMENT ASSEMBLY

8.5 Install stainless steel Hex Head Capscrews **901.228** so they bind tightly within the imperfect threads. Being careful not to damage the ring surface, saw off the tops of the screws. File flush and finish with crocus cloth. Remove any slivers.

Note Also cut off the bottom of a screw which has been installed into a drilled-through shroud. File flush and finish with crocus cloth.

Caution Check screw height. High spots or loose pieces can quickly score the close-clearance wear ring surfaces.

8.6 Wipe off the impeller mounting surfaces on shaft **210.263** and the bores of the impellers to be mounted.

8.7 Match the impellers to their corresponding shaft mounting surfaces using the diagram drawn up during disassembly. Note that one of the keyseats at the center of the shaft is somewhat longer than the impeller hub.

8.8 Clamp the shaft in a vice using soft jaws adjacent to the long center keyseat leaving sufficient room for impeller mounting over the center sleeve fit.

8.9 Heat the impeller **230.244** in an electric oven at a temperature of 450° F. (232° C.). No other process is acceptable.

8.10 Assemble the key **940.276** and a split ring **501.265** into the shaft. Dust shaft surface with molybdenum disulfide.

8.11 Grasp heated impeller with gloved hands and slide over the shaft end, eye side first, and engage the split ring which will fit in the impeller counterbore.

8.12 In a similar manner, heat and install center sleeve **533.232** snug against the impeller hub.

8.13 Assemble the key **940.277** into the shaft.

8.14 Heat the impeller **230.248**. Slide on to its fit hub side first, against the center sleeve. Mount a split ring into the groove and pull back the impeller over the split ring.

8.15 The remaining impellers and the throttle sleeve **522.233** can be assembled following this procedure.

Note: As the assembly continues, assemble a stationary ring **502.206** over the preceding impeller. Assemble an interstage bushing **541.209** over the hub of the impeller in hand before mounting the impeller on to the shaft.

8TUTF15

REPAIR BULLETIN

Sterling Fluid System (USA), Inc.

SUBJECT: CASE / ELEMENT ASSEMBLY

- 8.16 The element assembly is completed with the mounting of the throat bushings 456.218, the throttle bushing 542.215, the center bushing 546.210 and 2 stationary rings 502.203 and 502.206.
- 8.17 Support the element assembly at the radial bearing locations and check the runout at the shaft sleeve and wear ring surfaces. The TIR must be within the limits of the following table.

Location of readings to be on the mounted component wear part surfaces.	Pump Operating Speed - RPM				
	To 500	501 to 2000	2001 to 3800	3801 to 5500	5501 to 7500
	.006	.0045	.0035	.0025	.002

Note: At this point, it must be determined if rotating element balance is required. Consult a Peerless Pump representative for further details.

9.0 CASE CLOSING

Note: A new case gasket must be available at this time.

A pre-cut gasket or a sheet of gasket material should be supplied by Peerless Pump. Only material from Peerless Pump has the proper composition for high pressure sealing and "crush" for proper internal clearances.

Caution: Do not hammer, but cut gasket, to obtain internal shapes.

- 9.1 Examine the split line face of the volute case halves and the case studs installed in the bottom half. Remove any foreign material from the faces and bores, check for and remove any burrs or minor irregularities from the machined surfaces.
- 9.2 Rig rope slings around the shaft, lift the rotating element and lower it to almost final position in the bottom half case. Hold element above the case bore, align each ring and bushing to engage the anti-rotation pins in the slots and the ring tongues with the case grooves, then lower into position.
- 9.3 Place the two sections of a pre-cut case gasket over the case studs and against the stationary rings.

STUTF15

REPAIR BULLETIN

Sterling Fluid System (USA), Inc.

SUBJECT: CASE / ELEMENT ASSEMBLY

- 9.4 Rig chains to the two lifting points in the volute case top half. Wipe off the joint face, make sure the jackscrews are backed off and lower over the bottom half case studs. Insert taper pins through the top half flange and use these to guide the top half into place.
- 9.5 Case must seat under its own weight, then the taper pins can be seated and the lubricated capnuts installed over the case studs finger tight down to the flange.
- 9.6 Check total axial movement of the element in the case (Endo) at this time in accordance with **ADDENDUM No. 5 or 6**, as applicable. It should be no less than the amount recorded at disassembly.
- 9.7 Torque the case studs to the torque value shown in **ADDENDUM No. 2, Column 2** of this manual using the tightening sequence depicted. Loosen the taper pins but do not remove from case.
- 9.8 Recheck the Endo.
- 9.9 Examine the mechanical seal gland face and bores at each end of the pump. Remove any foreign material and trim off excess split line gasket material.
- 9.10 Inspect the gland studs and replace if damaged or corroded.
- 10.0 CASE/ELEMENT CENTERING AND SEALING**

Caution: The pump must be filled with product before turning by hand.

Stainless steel fitted pumps are particularly susceptible to "pick-up" and turning by hand should be avoided whenever possible.

Radial centering is necessary under the following circumstances.

- If the volute case has been machined.
- If new bearing housings are being installed.

Removing and replacing the rotating element should not effect the radial centering.

8TUTF15

REPAIR BULLETIN

SUBJECT: CASE / ELEMENT ASSEMBLY

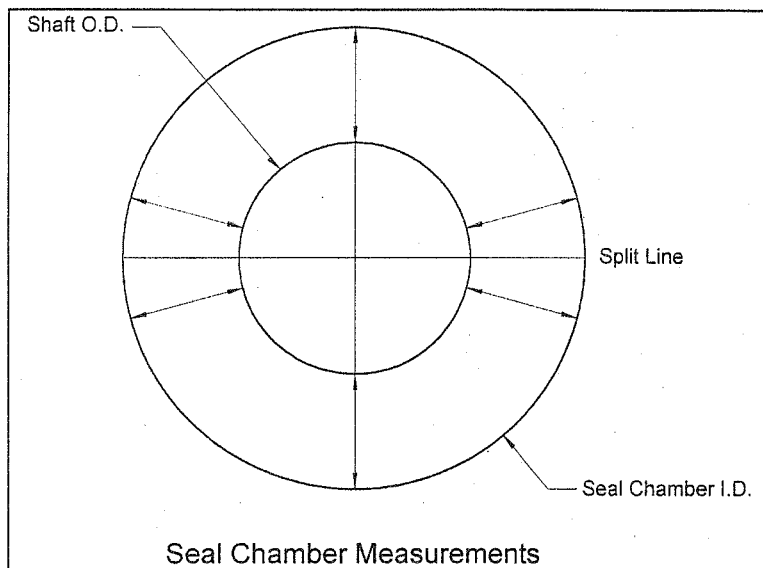

- 10.1 If the mechanical seals are installed, they must be removed. Refer to this section Para. 4.3 and 4.4 for details.
- 10.2 Install the bearings (ball, sleeve, or pivot) and the bearing housing at each end of the shaft. Refer to the **BEARING ASSEMBLY** Section for assembly procedure.
- 10.3 Take measurements at 6 locations in the case seal chamber as shown.
- 10.4 Adjust the element centering by bumping with a soft mallet or by applying the jackscrews mounted on either side of the bearing housing support flange when supplied.
- 10.5 Break loose the capscrews holding the housing to the case, and move the housing to adjust the centering by bumping or jacking.
- 10.6 Re-tighten the capscrews and recheck the centering at each end. Repeat until the 6 measurements are within .001 (.025 mm) of each other.
- 10.7 In the case of reusing old housings and a remachined volute case, it should be possible to open up the existing pin holes and fit a larger taper pin.
- 10.8 In the case of a new bearing housing drill and ream taper pin holes positioning the holes adjacent to but not in line with the old holes in the volute case. Fit pins and check that they will seat and not bottom out in the holes.

8TUTF15

REPAIR BULLETIN

SUBJECT: CASE / ELEMENT ASSEMBLY

- 10.9 Remove the bearing housings and bearings handling these parts as described in the **BEARING ASSEMBLY** Section of this manual.
- 10.10 Examine the mechanical seal assemblies to check that they are ready for assembly including an "O" ring in the sleeve bore and a gasket at the gland face.
- 10.11 Lubricate the shaft and slide the seal assembly into place taking care to correctly orientate the gland ports in accordance with the manufacturers drawing.
- 10.12 Install nuts and washers on to the gland studs but do not tighten at this time.
- 10.13 Complete the bearing assembly at each end of the pump as described in the **BEARING ASSEMBLY** Section of this manual.
- 10.14 Torque the seal gland studs to the torque value shown in **ADDENDUM No. 2, Column 3** of this manual using a tightening sequence that ensures proper gasket seating.
- 10.15 Tighten the seal drive collar set screws into the shaft surface and release seal setting spacers behind the drive collar.

This completes the case/element assembly.

Assemble the coupling hub as described in the **MAINTENANCE** Section of this manual.

Reinstall the pump, including realignment and coupling installation, as described in the **INSTALLATION** Section of this manual.

STUTF15

REPAIR BULLETIN

SUBJECT: SLEEVE / BALL BEARING ASSEMBLY
--

1.0 SCOPE

The preparation of parts and the method of assembling the Sleeve/Ball Bearing assembly and directions for disassembly.

Also, instructions for correct lubrication and operation.

2.0 PREPARATION

Study the Bearing Cross-Section drawing and be familiar with the design details and assembly sequence.

Phase the operations and have available equipment for bearing mounting or dismounting, measuring devices and heating facilities.

Be familiar with the heating temperatures, mounting and dismounting forces and the type and quantity of lubricant required.

Refer to torque value table in Addendum No.2 of this manual.

3.0 EXAMINATION AND CLEANLINESS

Caution: Absolute cleanliness is essential! Dirt and humidity are dangerous offenders since even the smallest particles penetrating into the bearing will damage the rolling surfaces. The work area must, therefore, be dust free, dry and well removed from machining operations. Avoid cleaning with compressed air.

Ensure cleanliness of shaft, housing and other mating parts. Castings must be free from sand. Bearing seats on the shaft and in the housing should be carefully cleaned from anti-rust compounds and residual paint. Turned parts must be free from burrs and sharp edges.

Check that all parts necessary for assembly are at hand and that they have been checked for dimensional and form accuracy.

New ball bearings will be in their original package. Do not wash out the anti-corrosive oil prior to assembly.

Used bearings should be washed with a cold-cleaning agent and oiled or greased immediately afterward.

STUTF15

REPAIR BULLETIN

Sterling Fluid System (USA), Inc.

SUBJECT: SLEEVE / BALL BEARING ASSEMBLY

5.13 Seat taper pins and torque capscrews to value shown in Addendum No. 2, Col. 1.

Release pins after torquing capscrews but leave loose in holes.

6.0 ASSEMBLY - THRUST BEARING (NON-DRIVE END - NDE)

6.1 Turning to the non-drive, hang an oil ring **644.340** on the journal bearing surface of the shaft.

6.2 Lift the bottom half of the bearing housing **350.304** into position flush with the pump case bearing bracket flange engaging the bearing isolator tongue in the locating groove in the housing bore.

6.3 Fit the capscrews **914.313** and hand tighten.

6.4 Support the weight of the bearing housing and install the taper pins **566.319**.

Note: If a new housing is being installed, follow element centering procedure described in the CASE/ELEMENT ASSEMBLY Section, Para 10.

6.5 Torque the capscrews to the correct value in Addendum No. 2, Col. 2 of this manual.

6.6 Ensure that the babbitt surface of the bottom half bearing **310.305** is wiped clean.

6.7 Lubricate the bottom half bearing and the shaft journal surface.

6.8 Raise the shaft slightly and install the bearing half in the housing engaging the bearing dowel pin in the slot in the housing bottom half.

6.9 Clean and lubricate the babbitt surface of the top half bearing, position the oil ring and place the top half on the bottom half. Secure with capscrews.

6.10 Prepare the spacer **869.325** to make up 1/2 X Endo given in the CASE/ELEMENT ASSEMBLY Section, Para 9.6 of this manual and position against the shaft axial centering shoulder.

6.11 The thrust bearing **320.345** is a tight fit on the shaft and must be heated for mounting. Control the temperature at 200/220° F. and heat uniformly using one of the following methods:

6.11.1 Remove from packaging and immerse in a pre-heated oil bath taking steps to avoid direct contact with the heat source or the tank bottom. Heat soak time is 10 minutes.



Sterling Fluid System (USA), Inc.

STUTF15

REPAIR BULLETIN

SUBJECT: SLEEVE / BALL BEARING ASSEMBLY

4.0 ASSEMBLY - GENERAL

Caution: Care in handling of components must be exercised to prevent damage or distortion of those components.

- 4.1 Slide a bearing isolator *426.361* as far as possible on to the shaft at each end of the pump.
- 4.2 Complete the assembly of each housing as described in Paragraphs 5.0 and 6.0.

5.0 ASSEMBLY - RADIAL BEARING (DRIVE END - DE)

- 5.1 Working at the drive shaft end, hang an oil ring *644.340* on the journal bearing surface of the shaft.
- 5.2 Lift the bottom half of the bearing housing *350.302* into position flush with the pump case bearing bracket flange, engaging the bearing isolator tongue in the locating groove in the housing bore.
- 5.3 Fit the capscrews *914.313* and hand tighten.
- 5.4 Support the weight of the bearing housing and install the taper pins *566.319*.

Note: If a new housing is being installed, follow element centering procedure described in the CASE/ELEMENT ASSEMBLY Section, Para 10.

- 5.5 Torque capscrews to the correct value in Addendum No. 2, Col. 2 of this manual.
- 5.6 Ensure that the babbitt surface of the bottom half bearing *310.303* is wiped clean.
- 5.7 Lubricate the bottom half bearing and the shaft journal surface.
- 5.8 Raise the shaft slightly and install the bearing half in the housing engaging the bearing dowel pin in the slot in the housing bottom half.
- 5.9 Clean and lubricate the babbitt surface of the top half bearing, position the oil ring and place the top half on the bottom half. Secure with capscrews.
- 5.10 Make sure the bearing housing split line faces are clean and then apply a thin coat of RTV silicone sealer (Dow Corning 732 or equivalent) to the bottom half face.
- 5.11 Lower the top half over the bottom half.
- 5.12 Insert taper pins and install capscrews finger tight.

STUTF15

REPAIR BULLETIN

SUBJECT: SLEEVE / BALL BEARING ASSEMBLY
--

6.11.2 Leave in packaging and place in a pre-heated convection oven or use an induction heater. Heat soak time is 45 minutes.

No other method is acceptable.

6.12 Assemble the bearing on the shaft. The duplex set is to be mounted in a back-to-back configuration.

6.13 Mount the centering ring *511.343* on to the shaft against the bearing.

6.14 The duplex bearing, the centering ring and the spacer will be held together against the shaft shoulder using the bearing locknut *923.328* assembled with the bearing lockwasher *931.332*.

6.15 After a while, the bearing and the shaft will reach the same temperature at which time the bearing can be seated using a spanner wrench to torque the locknut.

Caution: Ensure that the bearing nut and tab washer have a full face contact before achieving the final torque tightening of the bearing nut.

6.16 Manually apply a steady force on the wrench handle until the correct tightening is achieved. Refer to the torque values that are given in the torque values Addendum No. 2. Test the degree of tightening by turning the two outer races by hand, one relative to the other. A moderate force to achieve this indicates correct seating.

6.17 Lock the nut with the lockwasher.

6.18 Temporarily install the bearing housing top half on to the bottom half.

6.19 Insert taper pins and install capscrews finger tight.

6.20 Temporarily install the bearing end cover *361.335* using the full shim set *592.338* and secure with capscrews *901.315*.

6.21 Mount a dial indicator at pump drive end to check shaft endo. Adjust shim set *592.338* to provide .002/.004 movement.

6.22 Remove bearing end cover and bearing housing top half.

6.23 Reinstall top half after cleaning the split line faces and applying a thin coat of RTV silicone sealer (Dow Corning 732 or equivalent).

6.24 Replace taper pins and capscrews finger tight.

6.25 Seat the taper pins and torque the capscrews to value shown in Addendum No. 2, Col. 1. Release pins after torquing but leave loose in holes.

8TUTF15

REPAIR BULLETIN

Sterling Fluid System (USA), Inc.

SUBJECT: SLEEVE / BALL BEARING ASSEMBLY

- 6.26 Install "O" ring 412.337 in bearing end cover.
- 6.27 Lubricate "O" ring seating surface and push cover into housing being sure to use the adjusted shim set 592.338. Secure with capscrews.

7.0 ASSEMBLY - ATTACHMENTS

Various additional parts must be assembled to complete the bearing assemblies. The make-up of the parts is dependent on whether or not purge mist is required with the ring oil lubrication system and also on the type of cooling system required for the application.

The optional final assemblies are as follows. Select the option required for the order which should match the bearing sectional drawing included in this manual.

7.1 Ring oil lubrication without cooling.

- 7.1.1 Install the nipple 760.349 into the tapped hole in each housing and the oiler 638.348 on to the nipple. Use sealer, but not PTFE tape, on the threads.

Note: The illustration on the drawing shows the oiler position for CCW rotation when viewing from the coupling end.

Use the hole on the opposite side of the housing for CW rotation.

- 7.1.2 Install plugs 903.308, 903.309, 903.352 and 903.353 into the fill and drain connections and the unused oiler connection.

Install the sight glass 642.384 at the location indicated.

Use sealer, but not PTFE tape, on all threaded fittings.

7.2 Ring oil lubrication with fan cooling.

- 7.2.1 Install the nipple 760.349 into the tapped hole in each housing, and the oiler 638.348 on to the nipple. Use sealer, but not PTFE tape, on the threads.

Note: The illustration on the drawing shows the oiler position for CCW rotation when viewing from the coupling end.

Use the hole on the opposite side of the housing for CW rotation.

8TUTF15

REPAIR BULLETIN

SUBJECT: SLEEVE / BALL BEARING ASSEMBLY

7.2.2 Install the air release filter *673.351* into the fill connection.

Install plugs *903.308*, *903.309* and *903.353* into the drain connection, the unused oiler connection and the second fill connection on the thrust end housing respectively.

Install the sight glass *642.384* at the location indicated.

Use sealer, but not PTFE tape, on all threaded fittings.

7.2.3 Install the bearing isolator assembly *426.363* into the bearing cover *360.335*.

Slide the bearing isolator rotor into place with the stator ensuring correct alignment and clearance is maintained.

7.2.4 Install the key *940.378* into the shaft and mount the fan *831.370* securing with the retaining ring *932.377*.

7.2.5 Attach the fan shroud *832.372* on to the housing ribs using socket head capscrews *914.375*.

7.3 Ring oil lubrication with cooling insert.

7.3.1 Install the nipple *760.349* into the tapped hole in each housing and the oiler *638.348* on to the nipple. Use sealer, but not PTFE tape, on the threads.

Note: The illustration on the drawing shows the oiler position for CCW rotation when viewing from the coupling end.

Use the hole on the opposite side of the housing for CW rotation.

7.3.2 Install plugs, *903.308*, *903.309*, *903.352* and *903.353* into the fill and drain connections and the unused oiler connection.

Install the sight glass *642.384* at the location indicated.

Use sealer, but not PTFE tape, on all threaded fittings.

7.3.4 The cooling insert *442.390* is made up of a finned tube and pipe fittings to secure it in the bearing housing. The bearing housing (non-drive end) requires two inserts, the bearing housing (drive end) requires one.

7.3.5 Install a male thermocouple connector with thread sealer on the threads into the smaller of the two cooler connections in the housings.

STUTF15

REPAIR BULLETIN

SUBJECT: SLEEVE / BALL BEARING ASSEMBLY

- 7.3.6 Install the other male thermocouple connector into the 1-1/2 inch NPT bushing. Use thread sealer, but not PTFE tape, on the threads.
 - 7.3.7 Mount the finned tube into the bearing housing through the large hole inserting the tube end into the male thermocouple connector already assembled. Leave tube loose in the connector.
 - 7.3.8 Slide the 1-1/2 inch NPT bushing with connector over the free end of the finned tube and screw bushing into the large hole.
 - 7.3.9 Check total axial movement of finned tube in the connectors and position at the center of the movement. Secure tube by tightening the connector nuts over the ferrules.
 - 7.3.10 Attach the tube connectors, one on each end of the finned tube to complete the assembly.
- 7.4 **Modification for purge mist.**

Note: This modification can be applied to all the Ring Oil systems as described in Paras 7.1, 7.2 and 7.3 above.

The Bearings Housings *650.302* and *650.304* supplied when purge mist is ordered will have a 0.25 inch NPT supply port at the top vertical centerline and a 0.25 inch NPT oiler balance line connection adjacent to each Trico Oiler port.

- 7.4.1 The standard Trico Oiler is replaced by a special Purge Mist Oiler Kit *638.348* which contains additional parts to be assembled as follows:

Bend the 0.25 inch OD tubing and assemble into the special Trico Oilers and into the oiler balance line connection in the bearing housings using the male connectors supplied.

Assemble one 0.25 inch NPT plug into the Purge Oil Supply port and another into the unused Trico Oiler balance line connection of each bearing housing.

- 7.4.2 Install the overflow tube into the unused connection opposite the Trico Oiler, when supplied, using the male connector. Alternatively install plug *903.309*.

8TUTF15

REPAIR BULLETIN

Sterling Fluid System (USA), Inc.

SUBJECT: TORQUE VALUES

1.0 PURPOSE

- 1.1 This process establishes the method and values for torquing fasteners to produce properly stressed joints with a minimum probability of fasteners breaking or loosening. Joint distortion will be avoided by using the correct tightening sequence during torque development.

2.0 METHOD

- 2.1 All fasteners are to be lubricated (if lubricants are permitted) with graphite and oil, molybdenum disulfide, or another anti-seize lubricant of comparable quality that is compatible with the fastener application. Cleaning specifications must be consulted to determine suitability or allowance of thread lubricant.
- 2.2 Consult the Parts List (if applicable) to determine the fastener and component material for torque values.
- 2.3 Consult the following Fastener Application guideline to determine the table to be used based on the fastener application.
- 2.4 Tighten opposing fasteners in an alternating sequence as illustrated on the following page when developing required torque.
- 2.5 Lubricate and install fasteners finger-tight. Develop the required fastener torque value in a minimum of three steps, with a maximum of 30 percent of the torque value being reached on the initial pass.
- 2.6 After the last torque-development pass, a final "check pass" tightening to the required torque value should be performed in a clockwise bolt to bolt sequence.

8TUTF15

REPAIR BULLETIN

Sterling Fluid System (USA), Inc.

SUBJECT: TORQUE VALUES

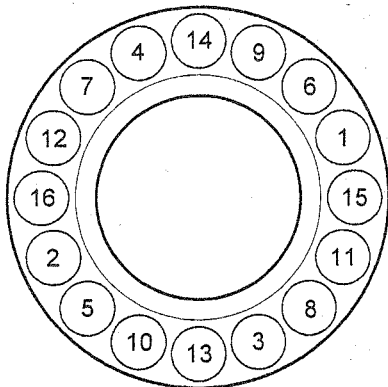

Circular Multi-Bolt, Example Pattern

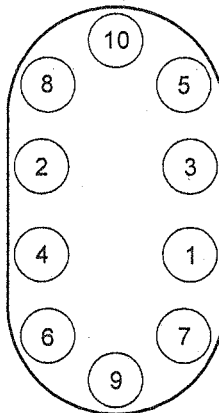

Non-Circular Multi-Bolt, Example Pattern

FASTENER APPLICATION	TABLE NUMBER
Bowl & column (vertical pump) Discharge head to receiver can (vertical pump) Isolation chamber, seal housing, Reservoir (J Unit application) Impeller retainer (Capscrew) Stuffingbox or Case Cover End Covers (Suct. & Disch) Seal plate Inner case (double case pump) Driver stand (vertical pump) Pump & driver mounting Coupling Bearing assembly & mounting components	1
Case Parting Flange (horizontal split case pump)	2
Raised face flange joint with gasket	3
Pump thrust end hold-down bolts for alignment keys	4
Bearing Nut Torque Values	5
Pivot Shoe Bearing Nut Torque Values	6

- 2.7 Refer to vendor instructions for proper torque values on vendor-supplied equipment.
- 2.8 Look for a grade identification marking on the fastener, then refer to the appropriate column in Torque Table 1, if the fastener is not covered by another specific table.
- 2.9 The material into which the fastener is threaded must also be considered. A 0.750 inch fastener of A193 grade B7, threaded into AISI 316 stainless steel (SS) material, is tightened to 62 LB_f*ft. The same fastener in a steel raised face flange with gasket is tightened to 155 LB_f*ft (Table 3).
- 2.10 Where the material or fastener grade marking is unknown, and the application is for Table 1, use the values in column 7 (AISI 304, 316 or monel material).
- 2.11 Case Parting Flange Torque Values (Table 2) must be established based on either materials of B7/L7 or B7M/L7M fasteners as appropriate.
- 2.12 Torque values in Tables 4 through 6 will be unchanged regardless of the fastener

material.



8TUTF15

Sterling Fluid System (USA), Inc.

REPAIR BULLETIN

SUBJECT: TORQUE VALUES

TABLE 1 (TORQUE VALUES)

COLUMN NO.	1		2		3		4		5		6		7	
MATERIAL & GRADE	A &SA193 Gr B7 A & SA320 Gr L7		SAE Gr 5 A325 & A449 ASTM F468 - N05500 (Monel)		A193 Gr B6		A &SA193 Gr B7M A & SA320 Gr L7M		SAE Gr 2		SAE gr 1 ASTM A307 gr A or B		AISI 304, 316 ASTM A193 gr B8, B8M Monel	
FASTENER														
SIZE	lbf*ft	N*m	lbf*ft	N*m	lbf*ft	N*m	lbf*ft	N*m	lbf*ft	N*m	lbf*ft	N*m	lbf*ft	N*m
0.250 - 20 UNC	8	11	7	9	6	9	6	8	4	6	3	4	2	3
0.3125 - 18UNC	15	21	14	18	13	17	12	16	8	11	5	7	4	6
0.375 - 16 UNC	27	36	23	31	21	29	20	27	14	20	9	12	8	10
0.4375 - 14UNC	41	56	36	49	34	46	32	43	23	31	14	19	12	16
0.500 - 13 UNC	63	86	55	75	51	69	48	65	34	47	22	29	18	24
0.625 - 11 UNC	124	168	109	147	100	136	95	128	67	91	43	58	35	48
0.750 - 10 UNC	217	295	190	258	176	238	165	224	118	160	74	101	62	84
0.875 - 9 UNC	347	470	304	412	281	381	264	358	119	161	119	161	99	134
1.000 - 8 UNC	517	702	453	615	419	568	394	535	177	241	177	241	148	200
1.125 - 8 UN	750	1017	579	785	607	824	572	775	257	349	257	349	214	291
1.250 - 8 UN	1044	1415	805	1092	845	1146	795	1078	358	485	358	485	298	404
1.375 - 8 UN	1405	1905	1084	1469	1137	1542	1070	1451	482	653	482	653	401	544
1.500 - 8 UN	1840	2496	1420	1925	1490	2020	1402	1901	631	856	631	856	526	713
1.625 - 8 UN	2375	3221	1312	1779	1923	2608	1810	2454	-	-	814	1104	679	920
1.750 - 8 UN	2964	4019	1637	2220	2399	3254	2258	3062	-	-	1016	1378	847	1148
2.000 - 8 UN	4470	6061	2469	3348	3618	4907	3406	4618	-	-	1533	2078	1277	1732
2.250 - 8 UN	6414	8698	3543	4804	5192	7041	4887	6627	-	-	2199	2982	1833	2485
2.500 - 8 UN	8853	12004	4890	6631	7166	9718	6745	9146	-	-	3035	4116	2529	3430
2.750 - 8 UN	10714	14528	6541	8870	9586	12999	-	-	-	-	4060	5505	3383	4588
3.000 - 8 UN	13966	18938	8527	11562	12496	16944	-	-	-	-	5292	7176	4410	5980

NOTE: Torque values are based on 60% of material yield strength except for the following:
 SAE Grade 8 fasteners and Socket Head Capscrews shall be torqued to column 1 values.
 All other material grades not listed or unidentifiable fasteners are to be torqued to column 7 values.



Sterling Fluid System (USA), Inc.

8TUTF15

REPAIR BULLETIN

SUBJECT: TORQUE VALUES

TABLE 2

CASE PARTING FLANGE (HORIZONTAL SPLIT CASE PUMPS)				
MATERIAL & GRADE	A & SA193 Gr B7 A & SA320 Gr L7		A & SA193 Gr B7M A & SA320 Gr L7M	
	lbf*ft	N*m	lbf*ft	N*m
FASTENER SIZE				
0.250 - 20 UNC	-	-		
0.3125 - 18UNC	-	-		
0.375 - 16 UNC	-	-		
0.4375 - 14UNC	-	-		
0.500 - 13 UNC	-	-		
0.625 - 11 UNC	-	-		
0.750 - 10 UNC	280	379	213	289
0.875 - 9 UNC	-	-	-	-
1.000 - 8 UNC	661	896	504	683
1.125 - 8 UN	968	1312	737	1000
1.250 - 8 UN	1329	1802	1013	1373
1.375 - 8 UN	1784	2420	1360	1844
1.500 - 8 UN	2339	3171	1782	2416
1.625 - 8 UN	2969	4026	2262	3068
1.750 - 8 UN	3506	4754	2671	3622
2.000 - 8 UN	5215	7071	3973	5388
2.250 - 8 UN	7486	10152	5704	7735
2.500 - 8 UN	10532	14282	8024	10881
2.750 - 8 UN	12495	16943	-	-
3.000 - 8 UN	-	-	-	--

TABLE 3

RAISED FACE FLANGE JOINT WITH GASKET				
FASTENER SIZE	TABLE 1 Col 1-4 MTL		TABLE 1 * Col 5-7 MTL	
	lbf*ft	N*m	lbf*ft	N*m
FASTENER SIZE				
0.250 - 20 UNC	6	8	2	3
0.3125 - 18UNC	11	15	4	6
0.375 - 16 UNC	19	26	8	10
0.4375 - 14UNC	30	40	12	16
0.500 - 13 UNC	45	61	18	24
0.625 - 11 UNC	89	120	35	48
0.750 - 10 UNC	155	210	62	84
0.875 - 9 UNC	248	336	99	134
1.000 - 8 UNC	370	501	148	200
1.125 - 8 UN	536	727	214	291
1.250 - 8 UN	745	1011	298	404
1.375 - 8 UN	1003	1361	401	544
1.500 - 8 UN	1315	1783	526	713
1.625 - 8 UN	1697	2301	679	920
1.750 - 8 UN	2117	2871	847	1148
2.000 - 8 UN	3193	4329	1277	1732
2.250 - 8 UN	4582	6213	1833	2485
2.500 - 8 UN	6323	8574	2529	3430
2.750 - 8 UN	8458	11469	3383	4588
3.000 - 8 UN	11026	14951	4410	5980

TABLE 4

PUMP THRUST END HOLD-DOWN BOLTS FOR HOT ALIGNMENT KEYS		
FASTENER SIZE	lbf*ft	N*m
FASTENER SIZE		
0.250 - 20 UNC	-	-
0.3125 - 18UNC	-	-
0.375 - 16 UNC	-	-
0.4375 - 14UNC	-	-
0.500 - 13 UNC	-	-
0.625 - 11 UNC	-	-
0.750 - 10 UNC	35	47
0.875 - 9 UNC	55	75
1.000 - 8 UNC	85	115
1.125 - 8 UN	125	170
1.250 - 8 UN	175	237
1.375 - 8 UN	240	325
1.500 - 8 UN	300	407
1.625 - 8 UN	400	542
1.750 - 8 UN	500	678
2.000 - 8 UN	750	1017
2.250 - 8 UN	-	-
2.500 - 8 UN	-	-
2.750 - 8 UN	-	-
3.000 - 8 UN	-	-

* Ensure that these values will allow clamping pressure adequate enough to seal the joint.



STUTF15

Sterling Fluid System (USA), Inc.

REPAIR BULLETIN

SUBJECT: TORQUE VALUES

TABLE 5 (BEARING NUT TORQUE VALUES)

Locknut Designation	7300 SERIES ANG CONT BALL BRGS		6300 SERIES DP GRV BALL BEARINGS		6200 SERIES DP GRV BALL BEARINGS	
	Maximum Allowable Tightening Torque **		Maximum Allowable Tightening Torque **		Maximum Allowable Tightening Torque **	
	lbf*ft	N*m	lbf*ft	N*m	lbf*ft	N*m
N-06	20	25	15	20	11	15
N-07	25	30	20	30	17	25
N-08	35	50	30	40	25	35
N-09	50	70	45	60	30	45
N-10	70	95	60	85	35	50
N-11	90	125	80	110	50	70
N-12	115	155	100	135	65	85
N-13	145	195	125	170	85	115
N-14	175	235	150	210	100	135
AN-15	220	295	185	250	115	160
AN-16	260	350	220	300	140	190
AN-17	310	420	260	355	175	235
AN-18	360	490	310	420	210	285
AN-19	425	580	360	490	250	335
AN-20	525	710	450	610	300	405
AN-21	600	815	515	700	350	475
AN-22	680	920	635	860	415	565

** Torque Values are based on lightly oiled threads

TABLE 6 (PIVOT SHOE BEARING NUT TORQUE VALUES)

THRUST BEARING SIZE	** TORQUE VALUE	
	lbf*ft	N*m
JHJ-4	100	135
JHJ-5	100	135
JHJ-6	100	135
JHJ-7	150	203
JHJ-8	150	203
JHJ-9	150	203

** Torque Values are based on lightly oiled threads

8TUTF15

REPAIR BULLETIN

Sterling Fluid System (USA), Inc.

SUBJECT: ELEMENT END MOVEMENT ADJUSTMENT

PURPOSE

This procedure is used to determine the length of the centering ring of the ball/ball bearing or the spacer of the ball/sleeve bearing.

PROCESS

1. Pull the rotating element to the outer limit in the non-drive direction.
2. Measure the distance from the shaft shoulder to the bearing bracket. (Dim'n 'A₁')
3. Push the rotating element to the outer limit in the drive direction.
4. Measure the distance from the shaft shoulder to the bearing bracket. (Dim'n 'A₂')
5. Calculate 'A_{AVG}' from the measurements taken in Step 2 and Step 4. Use the following equation.

$$A_{AVG} = .5(A_1 + A_2)$$

6. Determine the value of 'B' from the table below.
7. Calculate the length of the centering ring/spacer (C) from the following equation.

$$C = B - A_{AVG}$$

8. Machine the center ring/spacer to length 'C'.

When machining centering ring/spacer, the machined surface must be parallel to .001" to Datum -A- (as shown below).

Bearing Housing	'B'
#1 Ball/Ball Bearing	1.750
#2 Ball/Ball Bearing	1.750
#1 Ball/Sleeve Bearing	4.844
#2 Ball/Sleeve Bearing	5.688

