

End suction pumps, close coupled series PE-B and PE-C; frame mounted series PB-B and PB-C

Instructions

- Installation
- Operation
- Maintenance

Read this entire book

before attempting to install, operate or repair this pump. Properly installed, your Peerless pump will give you satisfactory, dependable service. We urge that you read carefully these step-by-step instructions, to simplify any problems of installation, operation or repair.

Failure to read and comply with installation and operating instructions will void the responsibility of the

manufacturer and may also result in bodily injury as well as property damage.

This book is intended to be a permanent part of your pump installation and should be preserved in a convenient location for ready reference. If these instructions should become soiled obtain a new copy from Peerless Pump. Include pump model and/or serial number with your request.

WARRANTY

New equipment manufactured by Seller is warranted to be free from defects in material and workmanship under normal use and service for a period of one year from date of shipment; Seller's obligation under this warranty being limited to repairing or replacing at its option any part found to its satisfaction to be so defective provided that such part is, upon request, returned to Seller's factory from which it was shipped, transportation prepaid. This warranty does not cover parts damaged by decomposition from chemical action or wear caused by abrasive materials, nor does it cover damage resulting from misuse, accident, neglect, or from improper operation, maintenance, installation, modification or adjustment. This warranty does not cover parts repaired outside Seller's factory without prior written approval. Seller makes no warranty as to starting equipment, electrical apparatus or other material not of its manufacture, since the same are usually covered by warranties of the respective manufacturers thereof.

In the event, notwithstanding the terms of this agreement, it is determined by a court of competent jurisdiction that an express warranty has been given by Seller to Purchaser with respect to the head, capacity or other like performance characteristics of said equipment, Seller's liability for breach of the same shall be limited to accepting return of such equipment F.O.B. plant of manufacture, refunding any amount paid thereon by Purchaser (less depreciation at the rate of 15% per year if Purchaser has used equipment for more than thirty (30) days) and cancelling any balance still owing on the equipment.

THIS WARRANTY IS EXPRESSLY IN LIEU OF ANY OTHER WARRANTIES, EXPRESSED OR IMPLIED, AND SELLER SPECIFICALLY DISCLAIMS ANY IMPLIED WARRANTY OF MERCHANTABILITY OR FITNESS FOR A PARTICULAR PURPOSE.



Peerless Pump Company
2005 Dr. Martin Luther King Jr. Street
Indianapolis, IN 46202
Phone: (317) 925-9661 • Fax: (317) 924-7388

Sterling Fluid Systems (USA), Inc.

2891096
REV. 8/85

IMPORTANT SAFETY PRECAUTIONS

Pump parts, and the tools and rigging equipment used in installing pumps, are heavy and may easily cause personal injury if dropped or carelessly handled. The normal precautions and safety rules associated with the erection of heavy machinery, in regard to manual lifting, use of power equipment, and handling of tools, must be observed in the installation of this pump.

Petroleum-base cleaning solvents are flammable. Smoking by personnel in the vicinity of these solvents is extremely hazardous and must not be permitted.

Do not work under a heavy suspended object unless there is a positive support under it to stop its fall in event of sling or hoist failure. Disregard of this warning could result in grave personal injury.

Before opening the conduit box of an electric motor, be certain that the current to the motor is shut off. An electrical shock from contact with live motor leads can be fatal.

Before attempting repairs to pump open the disconnect switch to electric motor. This prevents accidental running of pump motor. Starting motor during pump repair activities could damage pump and many cause personal injury.

Because cap screws have a tendency to loosen on shipment retighten all cap screws to casing and to motor adapter before installing pump. Refer to re-assembly instructions for torque values.

WARNING

The pumps described by this bulletin must not be installed in any manner except as specified herein and must not be operated at temperatures greater than 160°F or maximum working pressures greater than 75 psig.

These pumps must not be used to pump any fluid other

than that specified for the order. Liquids to be pumped must be non-corrosive and non-abrasive or damage can occur to pump.

Violation of this warning will void the warranty and may result in serious property damage or grave personal injury.

INTRODUCTION

UPON RECEIPT OF PUMP EQUIPMENT —

Check carefully to see that all of the equipment has been received. Report immediately any shortages or damages to the transportation company handling the shipment, noting the extent of the damage or shortage on the freight bill and bill of lading.

Do not leave the unit exposed to weather or construction hazards. The pump may become mechanically

damaged. This pump is a well designed and carefully manufactured unit. It should be given the same attention accorded to any precision machine.

The satisfactory operation of a pump depends to a large extent upon proper installation. These instructions cannot answer every question that may arise as each installation will be different. The installer and the operator of this equipment must use good judgement to adapt these procedures to his installation.

PUMP TYPES

Series PE-B, PE-C, PB-B and PB-C End Suction pumps are furnished with MECHANICAL SEAL only. The PB style frame is sold in a configuration which

accepts a coupled electric motor drive. This may be modified to belt drive configuration if desired. See figure 3 instructions.

INSTALLATION

WARNING

Do not work under a heavy suspended object unless there is a positive support under it to stop its fall in event of sling or hoist failure. Disregard of this warning could result in grave personal injury.

LOCATION: This pump should be installed in a clean, well-drained and ventilated location, and be accessible for inspection and proper care. Ample room should be provided for installation and removal.

FLOOR MOUNTING: A raised concrete foundation may be provided for convenience of elevation, but it is not required if the floor is level. If a concrete foundation is provided it should be solid and rigid to support the complete unit without deflection or vibration.

PIPING: To facilitate and simplify piping, the volute casing and discharge flange can be rotated to any one of 4 positions by removing the 4 adaptor-to-casing cap screws and rotating to the desired position. Suction piping should not contain any low points which can trap air. When the pump is located above the level of the water, a check-valve or foot valve should be installed in the suction line to maintain prime, and a priming tee should be so located at the discharge flange of the pump that the case and suction line can be completely

filled. If debris is apt to be present, a combination foot-valve strainer should be used. When the suction is under pressure, or the level of the water is above the pump, a valve and union should be installed in both the suction and discharge pipes to permit inspection and service of the pump at any time. To obtain optimum performance, suction pipe joints must be made up with pipe joint compound to insure that there are no air leaks. When the pump is located above the liquid or operating with a suction lift, even a small air leak in the suction line will materially reduce capacity of the pump or cause a loss of prime. If a union is required, use a gasket type and seal it with pipe joint compound. Also, the pump must not support heavy suction or discharge piping, and piping must not be forced into place because this could result in distortion and binding of rotating parts.

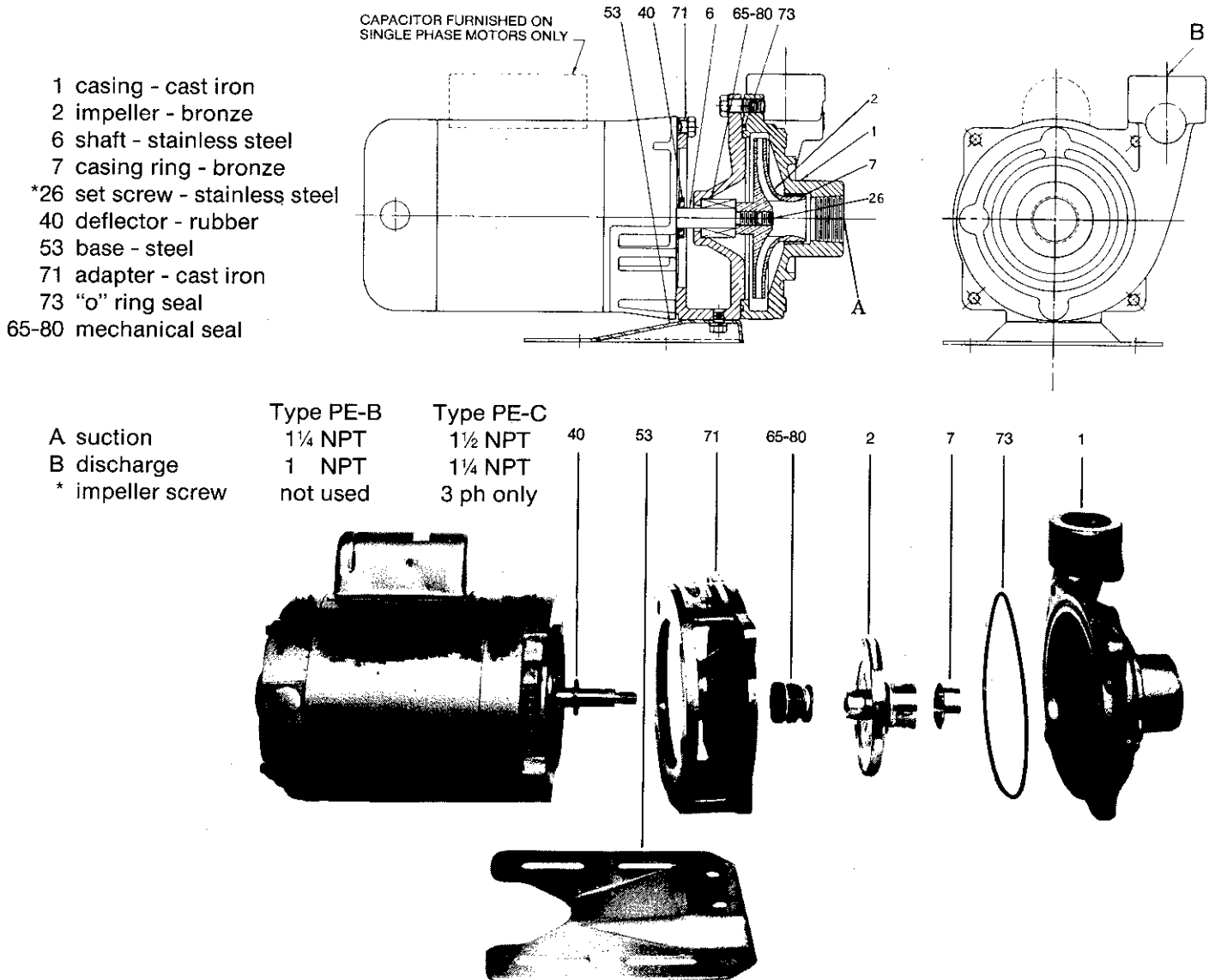

FIGURE 1. CLOSE COUPLED SERIES PE-B and PE-C

CAUTION

Make certain that the pump is free from piping strains which may cause misalignment, resulting in a possible binding of the rotating element. Avoid springing the piping into line and use caution when tightening the connections. Provide a suitable means (other than the pump) to support the weight of the suction and discharge piping. It is important, particularly in new pipe lines, that the piping is properly cleaned of all foreign material. Failure to adhere to these precautions can result in equipment damage and malfunction.

ELECTRICAL CONNECTIONS PE-B and PE-C: Be sure the motor terminals are connected for the voltage to be used. Connection diagrams can be found on the nameplate or inside the terminal cover. Single phase, 1/4 and 1/3 horsepower motors are wired for either 115 volts or 230 volts as desired; standard factory connections you receive should be 230 volts. Three phase motors may be of other voltage and are not pre-connected. Local and national electrical codes governing wiring should be observed.

MOTOR: The motor supplied with the Peerless end suction pump does not require lubrication — it is lifetime lubricated. It may have a build-in overload protection which will automatically reset as the motor cools, therefore, the main switch should always be open when working on the motor. If for any reason the motor is serviced or reconditioned, its rotation should be checked to be clockwise when looking toward the pump at the end opposite the shaft extension. Also, this end of the shaft, covered by a plug, has a screwdriver slot referred to elsewhere for holding or turning the motor shaft, pump, etc.

IMPELLER: The impeller rotating in the pump casing is the only moving part of a centrifugal pump. In case of reduced pressure or reduced capacity requiring service traceable to the impeller, its water passages should be inspected by passing a flexible wire, etc., from the outside toward the center to dislodge any obstructions. See DISASSEMBLY as required for this operation.

MECHANICAL SHAFT SEAL: A short run-in period may be required when a new unit is placed in operation before a perfect seal is effected in the mechanical shaft seal. However, there should be no leakage at the seal during normal operation. If considerable grit, etc., is present in the water, the seal may eventually become scored and develop a leak. In such case, the seal should be disassembled and all parts cleaned thoroughly. The rubber bellows should be examined for leaks and seal faces for scratches. Worn parts should be replaced, but emergency repairs may be made of the seal faces by smoothing these on No. 500 grit Carborundum paper placed on plate glass to

provide a flat surface. See DISASSEMBLY as required for this operation also.

PRIMING AND STARTING: When the pump is located above the level of the liquid, the pump must be primed by filling the case and suction line through the tee installed at the discharge flange. Be sure all the air has been expelled from the suction pipe and pump case.

CAUTION

Prime pump before starting motor or damage can occur to internal pump parts.

The rotation of single phase motors is predetermined by internal wiring, but the rotation of 3-phase motors must be checked at installation by momentarily closing the electric service switch and observing the rotation. It should be clockwise when looking toward the pump from the free end of the motor. Interchange of any 2 of the 3 power leads will reverse a 3 phase motor.

DISASSEMBLY: It is advisable that a competent pump mechanic be employed for disassembly and reassembly operations. Before starting disassembly of the pump, re-check to make certain that this operation is necessary. Close any valves that may be installed in the suction or discharge piping.

PE-B and PE-C: See figure 1. Remove the 4 case-to-adaptor screws and the mounting foot-screws. This permits removal as an assembly the motor, the adapter, the foot, and the impeller. Remove casing O-ring (130). The impeller (2) is now exposed for inspection and cleaning. See paragraph on impeller. The impeller is assembled to the motor shaft by 7/16-20 RH thread. On 3-phase, PE-C units, impellers are locked in place with a 7/16-20 hex socket set screw. If disassembly is necessary, hold the motor shaft with a screwdriver, engaging the slot which is covered by a cap at the opposite end, remove the set screw, if provided, and turn the impeller counterclockwise. The mechanical shaft seal (65-80) can now be removed for inspection, service, or replacement. Remove adapter (71) to motor frame screws. Remove adapter. Slide deflector from shaft.

PB-B and PB-C: See figure 2. Remove the 4 case-to-adaptor screws and remove casing (1) and casing O-ring (130). The impeller (2) is assembled to the shaft by 7/16-20 RH thread. Hold shaft (6) and turn impeller counterclockwise for removal. The mechanical seal (65-80) can now be removed for inspection, service or replacement.

Remove adapter (71) to bearing frame screws. Remove adapter. Slide deflector (40) from shaft. Remove snap ring (16A) from groove in bearing bore on pump end side of frame (19). Push shaft with bearings from frame.

Push in direction of pump end. If bearings (16-18) are to be removed, support on inner races and press shaft out.

NOTE: Bearings are sealed type. There is no need for cleaning or lubricating.

REPLACEMENT PARTS: When ordering replacement parts be sure to give both the model and serial numbers appearing on the nameplate on the top of the adapter, as well as the part name.

REASSEMBLY: Cleanliness is essential in the reassembly of any pump, especially to make sure that no grit, etc., is included between the surfaces of the mechanical shaft seal. Also, all connections should be made air and water tight.

PE-B and PE-C: Install deflector over shaft. Lubricate the cup or the O-ring of the mechanical seal floating seat, the seat cavity in adapter (71) and shaft where seal rides with any of MOLYCOTE® DC No. 55 silicone grease, 3% detergent solution, glycerine or ethylene glycol. Install floating seat in the adapter with lapped surface facing away from adapter shoulder. Seat adapter (71) against motor, then install screws and tighten uniformly. Rotate shaft by hand to check for free movement. Carefully install the mechanical seal cartridge assembly, lapped surface toward floating seat. Thread impeller (2) onto shaft rotating clockwise (RH thread) while holding shaft. Install the impeller

lock screw if one was provided. Install O-ring (73) into groove in case (1) and install onto adapter. Install screws and tighten uniformly to 10 ft-lbs.

PB-B and PB-C: If bearings (16-18) were removed from shaft (6), support shaft and press bearings on, applying force only against the inner race. Be sure inner race bottoms on shaft shoulder.

Carefully insert shaft through pump end of frame, coupling end first. Push shaft so that shoulder of pump end bearing contacts shoulder in frame bore. Install snap ring (16A) in proper groove in frame bore. Install deflectors (40) over shaft ends.

Lubricate the cup or the O-ring of the mechanical seal floating seat, the seat cavity in adapter (71) and shaft where seal rides, with any of MOLYCOTE® DC No. 55 silicone grease, 3% detergent solution, glycerine or ethylene glycol. Install floating seat in the adapter with the lapped surface facing away from adapter shoulder. Carefully install adapter onto frame register, then install screws and tighten uniformly. Rotate shaft by hand to check for free movement.

Carefully install the mechanical seal cartridge assembly, lapped surface toward floating seat.

Thread impeller (2) onto shaft rotating clockwise (RH thread) while holding shaft. Install O-ring (73) into groove in case (1) and install case onto adapter. Install screws and tighten uniformly to 10 ft-lbs.

	Type PE-B	Type PE-C
A suction	1/4 NPT	1/2 NPT
B discharge	1 NPT	1/4 NPT
26 impeller screw - stainless steel	not used	3 ph only

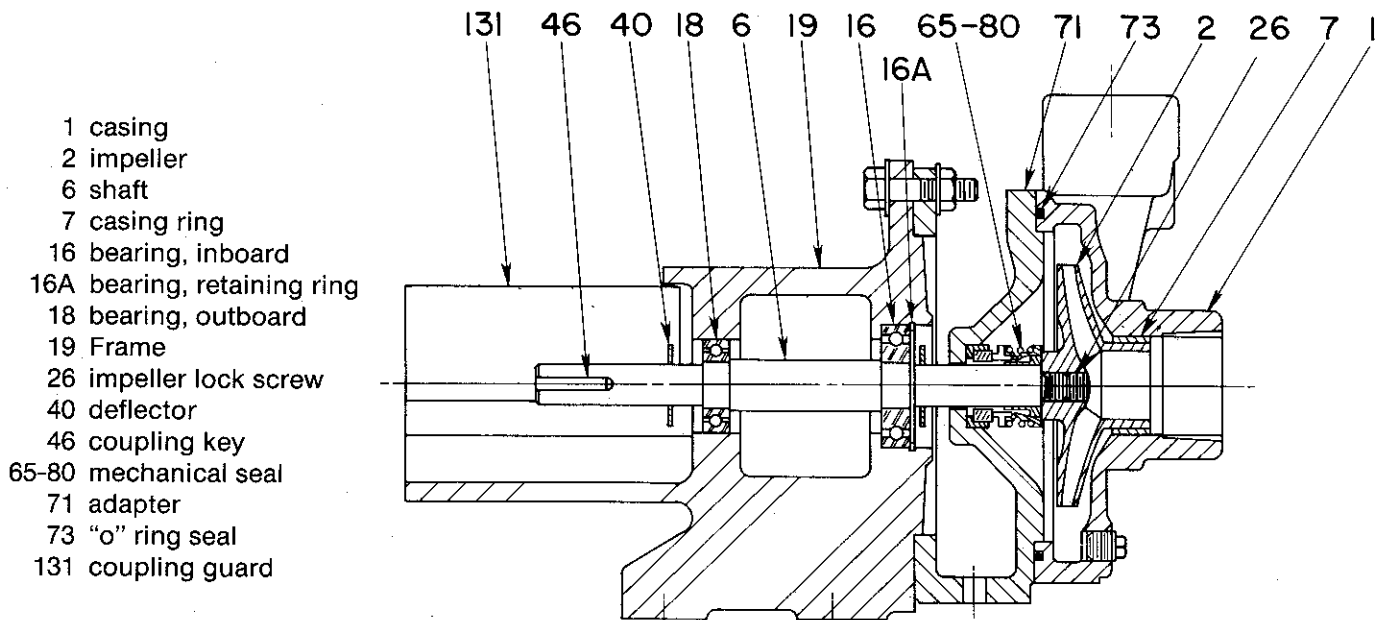
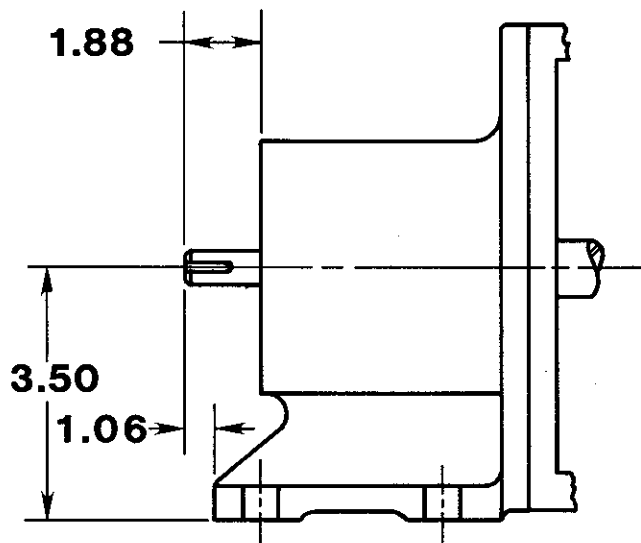

FIGURE 2. FRAME MOUNTED SERIES PB-B and PB-C

Sterling Fluid Systems (USA), Inc.

P.O. Box 7026 • Indianapolis, IN 46207-7026
 Phone: (317) 925-9661 • Fax: (317) 924-7388



FOR BELT DRIVE APPLICATIONS, COUPLING GUARD REMOVED BY SAWING AFTER COMPLETE DISASSEMBLY (COUPLING GUARD REMOVAL, SHEAVE AND BELT GUARDS BY OTHERS)

THE CENTER OF A 3.5 INCH MINIMUM DIAMETER (4L) SHEAVE SHALL BE PLACED A MAXIMUM OF .625 INCH FROM THE REAR EDGE OF THE FRAME.

FIGURE 3

LOCATING TROUBLE

IF PUMP AND MOTOR FAIL TO START:

1. Check for blown fuses or a tripped thermal overload relay.
2. Shaft may be stuck or binding due to rubbing of clogged impeller or other mechanical defect.
3. Starter contacts may be corroded, shorted, or terminal connections may be broken somewhere in the circuit.
4. The wiring hookup or voltage provided may be incorrect or switches may not be "set" for operation.

IF INSUFFICIENT OR NOT WATER IS DELIVERED:

1. Pump may not be primed. (See "Priming".)
2. The speed may be too slow. Check for low voltage.
3. The required discharge pressure may be higher than anticipated.
4. Suction pressure may be lower than anticipated.
5. The impeller may be clogged or damaged.
6. Wrong rotation. Check direction of shaft rotation with arrow on the pump casing.

7. The suction or discharge lines may be clogged or valves in lines may not be fully open.

IF PUMP LOSES PRIME:

1. The suction line may be leaking.
2. The suction pressure may be too low.
3. The pumped liquid may contain air or gas.

IF PUMP VIBRATES OR IS NOISY:

1. The foundation may be insufficient or not secure.
2. The impeller may be partially clogged causing an unbalanced condition.
3. Mechanical defects may be evident, such as a bent shaft, rotating element binding or worn bearings.
4. Suction or discharge pipes may not be anchored sufficiently.
5. The pump may be vapor bound—not fully primed. (See "Priming".)

Notice: Materials of construction, specifications, dimensions, design features, and application information, where shown in this bulletin, are subject to change and/or modification without notice by Peerless Pump at their option.