

MECHANICAL SEAL KIT

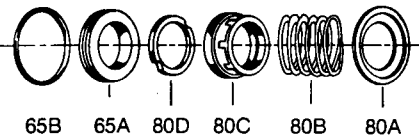

- *80A Spring Retainer
- 80B Spring
- 80C Seal Bellows Assy

- 80D Sealing Washer
- 65A Floating Seat
- 65B Seat Ring

*Some pumps have a step turned on the impeller hub to accept the spring and therefore do not have or use a spring retainer.

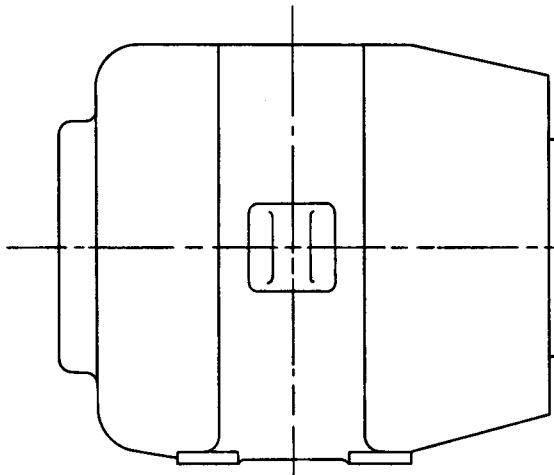

SERIES C PUMPS

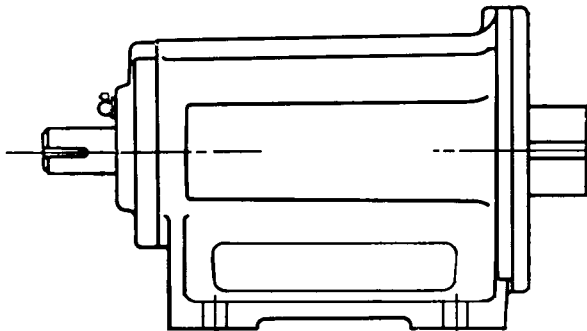

SERIES F PUMPS

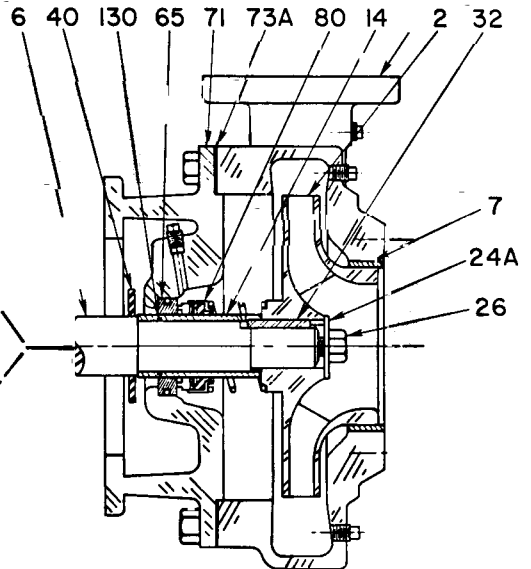

SEAL ASSEMBLY

Lubricate the O-ring (65B), groove in floating seat (65A) and seat cavity in adapter (71) with any of MOLYKOTE DC No. 55, glycerine or ethylene glycol.

Install floating seat in the adapter with lapped surface facing away from adapter shoulder. Secure adapter to motor or frame register. Lubricate surface of shaft sleeve and bores of sealing washer (80D) and spring bellows assembly (80C). Install shaft sleeve on shaft and carefully install sealing washer (lapped surface toward floating seat) and spring bellows assembly on shaft sleeve and slide down to contact floating seat. Install spring (80B) and spring retainer (80A) if used.

Install impeller key (32) in shaft keyway and make sure that key enters slot in shaft sleeve. Align impeller (2) with key and install on shaft while guiding the spring to seat on the shoulder of the impeller. Secure impeller with washer (24A) and lock screw (26).

Rotate shaft by hand to check for free movement.

- 1 Casing
- 2 Impeller
- 6 Shaft
- 7 Casing Ring
- 14 Shaft Sleeve
- 17 Gland
- 19 Frame
- 24A Impeller Washer
- 26 Impeller Lock Screw
- 32 Impeller Key
- 40 Deflector
- 65 Mechanical Seal, Stationary Element
- 71 Adapter
- 73A Casing Gasket
- 80 Mechanical Seal, Rotating Element
- 130 Shaft Sleeve O-Ring



Peerless Pump Company
2005 Dr. Martin Luther King Jr. Street
Indianapolis, IN 46202
Phone: (317) 925-9661 • Fax: (317) 924-7388

g Fluid Systems (USA), Inc.
: 7026, Indianapolis, IN 46207-7026
317) 925-9661 Fax: (317) 924-7388

4852863
7/91