

Repair Instructions

Type **TUBP-2** stage **TUBS-2** stage **TUAP-2** stage and **TUAS-2** stage Pumps



Peerless Pump Company
2005 Dr. Martin Luther King Jr. Street
Indianapolis, IN 46202
Phone: (317) 925-9661 • Fax: (317) 924-7388

2882316
Rev. 3/78

Read this entire book

before attempting to install, operate or repair this pump. Properly installed, your Peerless pump will give you satisfactory, dependable service. We urge that you read carefully these step-by-step instructions, to simplify any problems of installation, operating or repair.

Failure to read and comply with installation and operating instructions will void the responsibility of

the manufacturer and may also result in bodily injury as well as property damage.

This book is intended to be a permanent part of your pump installation and should be preserved in a convenient location for ready reference. If these instructions should become soiled obtain a new copy from Peerless Pump. Include pump model and/or serial number with your request.

WARRANTY

New equipment manufactured by Seller is warranted to be free from defects in material and workmanship under normal use and service for a period of one year from date of shipment; Seller's obligation under this warranty being limited to repairing or replacing at its option any part found to its satisfaction to be so defective provided that such part is, upon request, returned to Seller's factory from which it was shipped, transportation prepaid. This warranty does not cover parts damaged by decomposition from chemical action or wear caused by abrasive materials nor does it cover damage resulting from misuse, accident, neglect, or from improper operation, maintenance, installation, modification or adjustment. This warranty does not cover parts repaired outside Seller's factory without prior written approval. Seller makes no warranty as to starting equipment, electrical apparatus or other material not of its manufacture, since the same are usually covered by warranties of the respective manufacturers thereof.

In the event, notwithstanding the terms of this agreement, it is determined by a court of competent jurisdiction that an express warranty has been given by Seller to Purchaser with respect to the head, capacity or other like performance characteristics of said equipment, Seller's liability for breach of the same shall be limited to accepting return of such equipment F.O.B. plant of manufacture, refunding any amount paid thereon by Purchaser (less depreciation at the rate of 15% per year if Purchaser has used equipment for more than thirty (30) days) and cancelling any balance still owing on the equipment.

THIS WARRANTY IS EXPRESSLY IN LIEU OF ANY OTHER WARRANTIES, EXPRESSED OR IMPLIED, AND SELLER SPECIFICALLY DISCLAIMS ANY IMPLIED WARRANTY OF MERCHANTABILITY OR FITNESS FOR A PARTICULAR PURPOSE.

TUBP and TUBS pumps have a smaller interstage bushing and the cases are modified for the smaller bushing. TUAP and TUAS are obsolete models.

SECTION I DISASSEMBLY

WARNING

Shut down pump. Disconnect power to the pump driver before starting any repairs. Refer to Bulletin No. 2880549 for the procedure to follow.

1-1. Remove coupling guard. Disengage the drive coupling halves. Refer to the coupling manufacturer's instructions.

1-2. PUMP. (See figure 1 or 2.) Disassemble pump (to the extent required) as follows:

NOTE

Disassembly and reassembly instructions for both packed-type (Type TUAP & TUBP) and sealed-type (Type TUAS & TUBS) pumps are included in this Bulletin. Disregard the instructions which do not apply to the specific pump being repaired.

a. At the outboard bearing cartridge block (18), remove bearing cover with screw driver by prying outwardly in slot around cover.

b. Remove seal piping (127).

c. Loosen set screws in both bearing cartridge blocks (16 & 18). Do not remove set screws.

d. Remove the cap screws from each adapter (31 & 33).

e. On Type TUAP & TUBP pump, loosen gland bolt nut.

f. Lightly tap adapters next to case to separate case and adapters by 1/4 inch each side. Use soft face hammer for this.

g. Take off all cap screws from upper casing (1B). Remove taper dowel pins. Turn pump jack screw clockwise to separate upper casing from lower casing. After the casings have separated, turn jack screw back so that it will not interfere with the pump reassembly. Using eye bolt and hoist, lift off upper casing.

h. Use a suitable sling at shaft next to impeller inlets to lift rotating element from lower case. Place in a convenient work area.

1-3. ROTATING ELEMENT. Disassemble (to the extent required) as follows:

a. Loosen coupling set screw and tap coupling at back of its hub to remove from shaft. If coupling does not come off easily, use a suitable puller to pull from shaft. Extract coupling key (46).

b. On the Type TUAP & TUBP (figure 1) pump, remove nuts from gland bolts and detach gland halves (17) (separable) from shaft.

c. Remove the adapters (31 & 33) and cartridge blocks (16 & 18) as one assembly. The water deflectors will be pulled with adapters.

d. To remove either cartridge block (16 & 18) from its adapter (31 & 33) take out its four attaching cap screws. Support bracket on both sides at larger flange with cartridge on underside. With blunt tool tap around registered fit to remove the cartridge from the adapter. Do not disassemble bearing cartridge block, as it is replaced as a unit assembly.

e. On the Type TUAS & TUBS (figure 2) pump, carefully remove the mechanical seal rotating elements (80) and stationary elements (65). Do not nick or scratch faces of the stationary seat or rotating washer. Keep elements of same seal assembly together.

f. On the Type TUAS & TUBS (figure 2) pump, remove impeller nut (24). Use a suitable arbor press to slowly and carefully press shaft through impellers (2 and 2A). If an arbor press is not available, use a suitable tubular sleeve and mallet to carefully drive impellers from shaft. Take off interstage bushing (113). Extract impeller key (32).

g. On the Type TUAP & TUBP (figure 1) pump, pull packings (13), lantern rings (29), and stuffing box bushings (63) from bearing housings (31 & 33). Take off sleeve nut (20), lockwasher (69) and pull one shaft sleeve (14). Remove retaining ring from other end of shaft, and slide other shaft sleeve (14) from shaft. Remove two O-rings from sleeves.

h. On the Type TUAP & TUBP (figure 1) pump, remove impellers (2 and 2A), interstage bushing (113), and key (32) as in above step (g).

NOTE

Seals must not come in contact with or be exposed to hydrocarbon materials such as: gasoline, grease, oil, propane; cleaning agents such as: kerosene, lacquer, thinners, alcohol, etc.

1-4. CLEANING. Clean all metal parts (except seals and bearings) with a solvent. Use a bristle brush (NOT metal or wire) to remove tightly adhering deposits. A fiber scraper may be used to remove the gasket and shellac from casing flanges.

a. Blow dry with clean dry compressed air.

b. Check bearings as described in Bulletin No. 2880549. However, before cleaning, remove bearing covers only; do not remove bearing from housing.

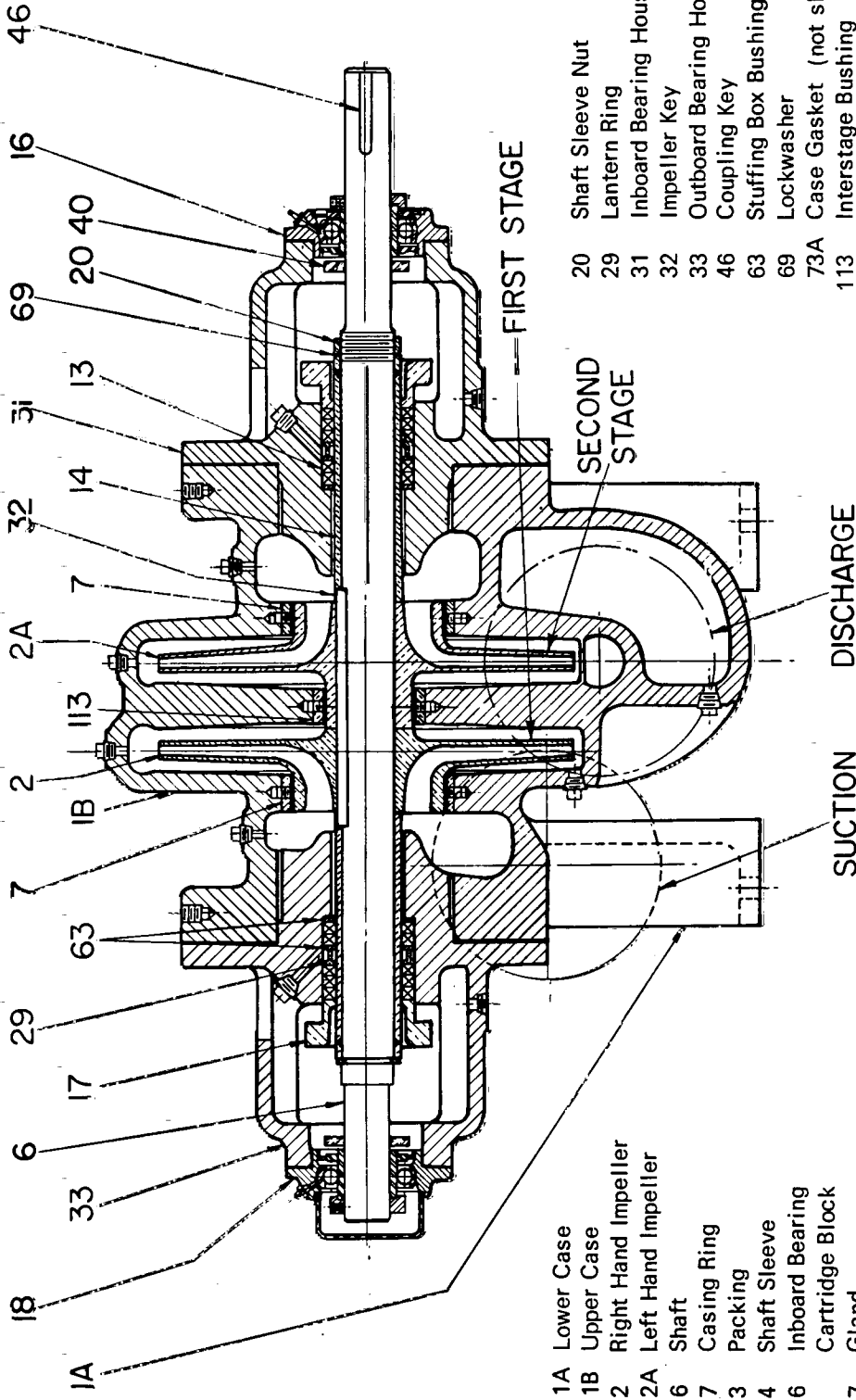

- 1A Lower Case
- 1B Upper Case
- 2 Right Hand Impeller
- 2A Left Hand Impeller
- 6 Shaft
- 7 Casing Ring
- 13 Packing
- 14 Shaft Sleeve
- 16 Inboard Bearing
- 17 Cartridge Block
- 18 Outboard Bearing
- Cartridge Block

- 20 Shaft Sleeve Nut
- 29 Lantern Ring
- 31 Inboard Bearing Housing Adapter
- 32 Impeller Key
- 33 Outboard Bearing Housing Adapter
- 46 Coupling Key
- 63 Stuffing Box Bushing
- 69 Lockwasher
- 73A Case Gasket (not shown)
- 113 Interstage Bushing
- 40 Water Deflector

PEERLESS PUMP DIVISION

INDIANAPOLIS, IND. LOS ANGELES CALIF.

REVISED MARCH 1978

DRAWING NO. 2881662-C

Figure 1. Type TUAP & TUBP Two-Stage Centrifugal Pump

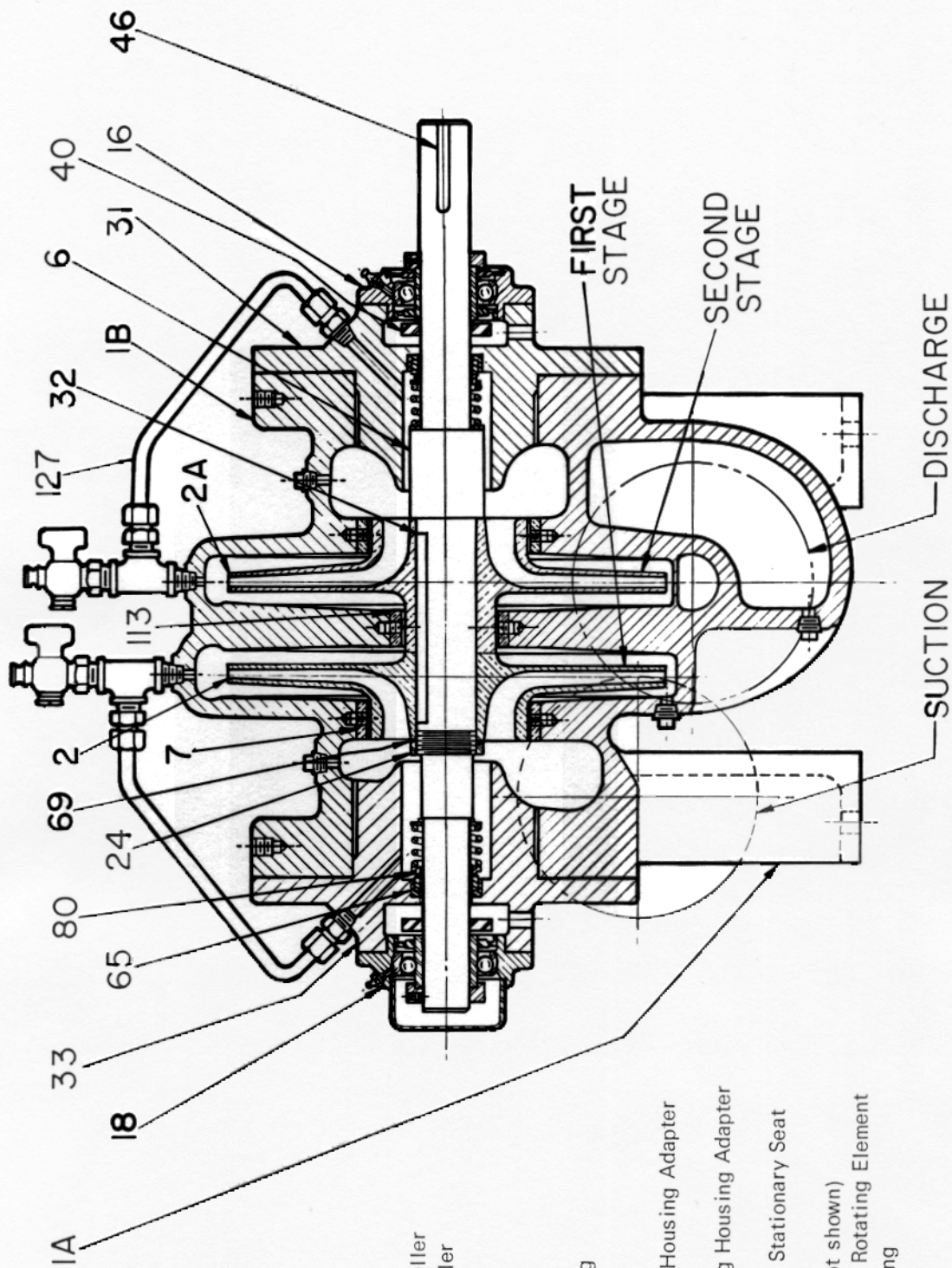

- 1A Lower Case
- 1B Upper Case
- 2 Right Hand Impeller
- 2A Left Hand Impeller
- 6 Shaft
- 7 Casing Ring
- 16 Inboard Bearing
- Cartridge Block
- 18 Outboard Bearing
- Cartridge Block
- 24 Impeller Nut
- 31 Inboard Bearing Housing Adapter
- 32 Impeller Key
- 33 Outboard Bearing Housing Adapter
- 46 Coupling Key
- 65 Mechanical Seal Stationary Seat
- 69 Lockwasher
- 73A Case Gasket (not shown)
- 80 Mechanical Seal Rotating Element
- 113 Interstage Bushing
- 40 Water Deflector
- 127 Seal Piping

PEERLESS PUMP DIVISION

DRAWING NO. 2881663-C REVISED MARCH 1978

INDIANAPOLIS, IND. LOS ANGELES, CALIF.

Figure 2. Type TUAS & TUBS Two-Stage Centrifugal Pump

SECTION II INSPECTION AND REPAIR

2-1. INSPECTION. Visually inspect parts for damage affecting serviceability or sealing. Emphasize inspection of mating parts having relative motion – wear rings, for example. Perform detailed inspection as follows:

- a. Check "O" rings and gaskets for shrinkage, cracks, nicks, or tears. The gasket at the case split must be flush with bore at area of stuffing box to obtain effective seal. When case split is open for any length of time gasket will shrink.
- b. Check packing rings for excessive compression, fraying, or shredding, embedded particles (dirt or metal). Replace if defective in any way.
- c. Mount the shaft between the lathe centers. Check the eccentricity throughout the entire length with a dial indicator to be not more than 0.003 inch total indicator reading. Surfaces on which bearings mount must be smooth, have a finish not more than 32 microinches and the shoulders square and free from nicks.
- d. Measure the OD of the impellers (2 and 2A) wear surface and the ID of the casing rings (7). Compute the diametrical clearance (ID minus OD) and compare with the limits given in Bulletin No. 2880549. ID surface of casing ring must be smooth and concentric.
- e. Measure smallest OD of impeller (2A) and ID of interstage bushing (113). Compute diametrical clearance and compare with limits given in Bulletin No. 2880549, figure 14.
ID surface of interstage bushing must be smooth and concentric.
- f. Examine impeller passages for cracks, dents, gouges or embedded material.
- g. Check upper and lower casing machined surfaces to be free of burrs or nicks.
- h. For Type TUAP pumps, inspect shaft sleeves (14) for excessive wear. Replace sleeves that are worn. Replace packing (13).

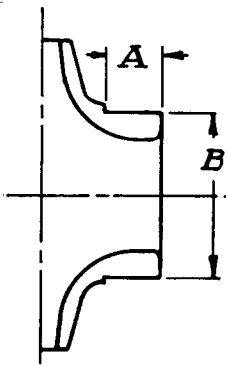

Figure 3. Impeller Dimensions for Wear Ring Installation

i. For Type TUAS pumps, examine mechanical seals for wear at the seal faces and for damage to the rubber bellows. Replace the complete seal if scoring or hardening of the rubber is evident, or if the seal's lapped faces are cracked, nicked or scored.

2-2. REPAIR. Make required repairs as follows:

- a. Replace shaft sleeves (14) if worn.
- b. Straighten or replace shaft (6) if it has excessive runout (eccentricity).
- c. Wear rings are available to eliminate excessive clearance between the impellers and casing ring, or impeller and interstage bushing.
If ID of casing ring (7) is grooved, scored, or eccentric, replace case ring. Check Bulletin No. 2880549 for diametrical clearance between impeller and case rings. Add 0.030 for maximum allowable clearance.
- d. If diametrical clearance is not within limits, the clearance can be restored by installing impeller wear rings on OD of impeller wearing surface.

NOTE

If impeller wear rings were previously installed, remove old rings by turning in a lathe; be sure machining is concentric with impeller bore. Use care not to reduce impeller ring skirt OD. If no rings were installed on impeller skirt, turn OD to diameter shown for model (see Figure 3).

e. Heat wear rings to a temperature that will enable the ring to drop onto the machined impeller skirts. The ID is factory machined for proper fit. Allow the assembly to cool to room temperature.

f. After installation, machine the wear rings OD to provide the nominal diametrical clearance shown in Bulletin No. 2880549.

| PUMP SIZE | REPAIR DIMENSIONS (INCHES) | |
|-------------|----------------------------|----------------|
| | A | B |
| TUAP & TUBP | 1.12 | 4.632 4.630 |
| TUAS & TUBS | 1.12 | 4.632 4.630 |

SECTION III REASSEMBLY

3-1. ROTATING ELEMENT, Type TUAP & TUBP Pump. (See figure 1).

- a. Coat the shaft (6) lightly with oil.
- b. Place impeller keys (32) on shaft.
- c. Install one O-ring in each of the shaft sleeves (14).
- d. Slide one shaft sleeve over outboard end of shaft, and engage notch of sleeve onto impeller key (32). Lock in place with sleeve retaining ring.
- e. Align impeller (2) on shaft, and seat on sleeve with an arbor press or with a tubular sleeve and mallet. Guard against bending shaft. When assembled, the impeller vanes must rotate in the proper direction. (See figure 4.)

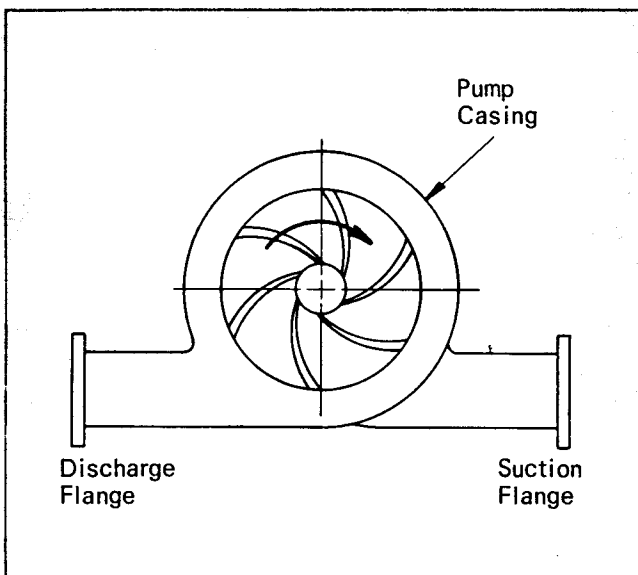

Figure 4. Vane Position for Proper Rotation

- f. Place interstage bushing (113) on impeller (2A), and press these two components onto shaft until seated against impeller (2).
- g. Install other shaft sleeve and lock in place with lockwasher (69) and sleeve nut (20).
- h. NOTE:
Inboard adapter is different from outboard adapter and must be installed in correct side. Hold adapter as you would be installing in pump case, the adapter that has the splitter 15° from top vertical is the outboard bearing housing adapter and is installed as shown in figure 2. (The splitter is a fin-like projection 1/4 inch thick on impeller side of the adapter.)

Place a casing ring (7) on each impeller. Then carefully slide each adapter over end of shaft. Be sure a gasket is on each adapter.

- i. In each of the adapters (31 and 33), install stuffing box bushing (63) at bottom. Insert two packing rings (13), stuffing box bushing, lantern ring and three more packing rings. Insert each ring separately and stagger the joints of successive rings 90°. Insert the glands (17) and set the nuts finger tight – DO NOT USE A WRENCH.
- j. Attach bearing cartridge blocks (16 and 18) to adapters with cap screws. Do not tighten bearing cartridge block set screws at this time.

3-2. ROTATING ELEMENT, Type TUAS & TUBS Pump. (See figure 2.)

NOTE

No oil may be used in the installation of seals. It is recommended that a silicone grease such as Dow-Corning 55M be substituted. If unavailable, use a 3% detergent solution or other type of mild soap solution.

- a. Coat shaft (6) lightly with oil, and place impeller key (32) in shaft slot.
- b. Align impeller (2A) on shaft, and seat on shaft shoulder with an arbor press or with a tubular sleeve and mallet. Guard against bending shaft.
- c. Place interstage bushing (113) on impeller (2A). Press other impeller (2) onto shaft to seat on impeller (2A). Lock in place with lockwasher (69) and impeller nut (24).
- d. Clean oil from shaft and lubricate with silicone grease.
- e. Slide a seal rotating element (80) over each end of shaft. Before completing the seal installation, wipe the lapped sealing faces of the seat and washer perfectly clean with a soft cloth.
- f. Install a seal stationary element (65) in each bearing adapter (31 and 33). Be careful not to damage seal elements during installation.
- g. Install bearing cartridge blocks (16 and 18) on each adapter, and attach with cap screws.
- h. See 3-1 letter "h" for note.
- i. Place a casing ring (7) on each impeller. Then carefully slide each adapter-and-bearing group over end of shaft. Be careful when engaging seal elements. Be sure a gasket is on each housing. Do not tighten bearing cartridge block set screws at this time.



Peerless Pump Company
2005 Dr. Martin Luther King Jr. Street
Indianapolis, IN 46202
Phone: (317) 925-9661 • Fax: (317) 924-7388

Sterling Fluid Systems (USA), Inc.
P.O. Box 7026, Indianapolis, IN 46207-7026
Phone: (317) 925-9661 Fax: (317) 924-7388

3-3. PUMP (see figure 1 or 2).

a. Use the upper case (1B) as a template to cut a case gasket (73A) from 1/64-inch vellumoid. Check that mating surfaces of both cases are clean and free from burrs or nicks. Shellac the gasket to the lower case (1A), and cover top of gasket with a mixture of graphite and oil.

b. Use slings around the rotating element and install into lower case. Position the casing rings (7) and interstage bushing (113) so that their dowel pins enter the lower case dowel holes.

c. Attach bearing housing adapters (33 and 31) with cap screws, leaving 1/4 inch separation between lower case and adapters.

d. Install the upper case over lower case so that all dowel pins engage. Secure with cap screws and tighten alternately and diagonally at opposite locations.

e. Install the rest of the bearing housing adapter cap screws and tighten all cap screws so that adapters clamp to the upper and lower casing.

f. Adjust shaft so that the outboard end is flush with the bearing cartridge block inner race (18). This will center the impellers in the volute and also provide the correct compression on the mechanical seal springs.

g. Tighten bearing cartridge blocks' set screws. Rotate shaft by hand to check that it runs free.

h. Replace all drain plugs removed during disassembly.

i. Relubricate the bearings. Refer to Bulletin No. 2880549.

j. Follow instructions in Bulletin No. 2880549 to check out the pump after repair and place the pump in service.

NOTICE: Materials of construction, specifications, dimensions, design features, and application information, where shown in this bulletin, are subject to change and/or modification without notice by Peerless Pump at their option.