

Multistage Diffuser Pumps

Types TMUB, TMUAH and J Jockey Pumps

Instructions

- **Installation**
- **Operation**
- **Maintenance**

Read this entire book

before attempting to install, operate or repair these controls. Properly installed, your Peerless Pump Company controls will give you satisfactory, dependable service. We urge that you read carefully these step-by-step instructions, to simplify any problems of installation or operation.

Failure to read and comply with installation and operating instructions will void the responsibility of the

manufacturer and may also result in bodily injury as well as property damage.

This book is intended to be a permanent part of your pump installation and should be preserved in a convenient location for ready reference. If these instructions should become soiled, obtain a new copy from Peerless Pump Company.



Peerless Pump Company

4848605
REV. 3/86

WARRANTY

New equipment manufactured by Seller is warranted to be free from defects in material and workmanship under normal use and service for a period of one year from date of shipment; Seller's obligation under this warranty being limited to repairing or replacing at its option any part found to its satisfaction to be so defective provided that such part is, upon request, returned to Seller's factory from which it was shipped, transportation prepaid. This warranty does not cover parts damaged by decomposition from chemical action or wear caused by abrasive materials, nor does it cover damage resulting from misuse, accident, neglect, or from improper operation, maintenance, installation, modification or adjustment. This warranty does not cover parts repaired outside the Seller's factory without prior written approval. Seller makes no warranty as to starting equipment, electrical apparatus or other material not of its manufacture, since the same are usually covered by warranties of the respective manufacturers thereof.

In the event, notwithstanding the terms of this agreement, it is determined by a court of competent jurisdiction that an express warranty has been given by Seller to Purchaser with respect to the head, capacity or other like performance characteristics of said equipment, Seller's liability for breach of the same shall be limited to accepting return of such equipment FCA plant of manufacture, refunding any amount paid thereon by Purchaser (less depreciation at the rate of 15% per year if Purchaser has used the equipment for more than thirty (30) days) and canceling any balance still owing on the equipment.

THIS WARRANTY IS EXPRESSLY IN LIEU OF ANY OTHER WARRANTIES, EXPRESSED OR IMPLIED, AND SELLER SPECIFICALLY DISCLAIMS ANY IMPLIED WARRANTY OF MERCHANTABILITY OR FITNESS FOR A PARTICULAR PURPOSE.

INSTALLATION AND OPERATION INSTRUCTIONS

1. GENERAL

Peerless models "TMUB", "TMUH" and "J" Jockey are multistage centrifugal, vertical, diffuser-type pumps. These pumps are designed to handle clear nonabrasive liquids at a maximum speed of 3500 RPM. These pumps are driven by electric motors only.

2. MOUNTING

Mount the pump on a level foundation. There are four 9/16" dia. mounting holes provided on the pump base. It is recommended that the pump be securely bolted to its foundation.

3. PIPING

WARNING Both the suction and discharge pipes should be supported independently near the pump so that no stress will be transmitted to the pump casing. Although the base tap size is 1 1/2", it is recommended that 2" or 2 1/2" pipe be used for suction piping to reduce friction loss. It must be tight to prevent air leaks and without excessive loops and bends. A check valve and gate valve should be installed in the discharge piping. The check valve should be placed between the

Pump and the gate valve. If the pump is operating under suction pressure, it is generally recommended to install a gate valve in the suction line (see Figures 1 & 2). Lines must be flushed to remove dirt before connecting to the pump. Small particles of dirt or scale can ruin pumps at start up.

4. FOOT VALVE

A foot valve must be used on all installations where the pump will be operating with suction lift. The foot valve retains water in pipes when the pump is not in operation, thereby insuring pump will not lose prime. When installing a new foot valve, always be sure that packing paper, etc., is not lodged in the foot valve openings, and that the foot valve holds water. If the pump will operate under suction pressure no foot valve will be required (see Figures 1 & 2).

5. SHAFT SEALING "TMUB" and "TMUAH"

This pump has been provided with either packing or a mechanical shaft seal. Maximum clear water operating conditions are: 230° F for a packing seal; 180° F at 200 psi, or 220° F at 150 psi for the standard mechanical seal.

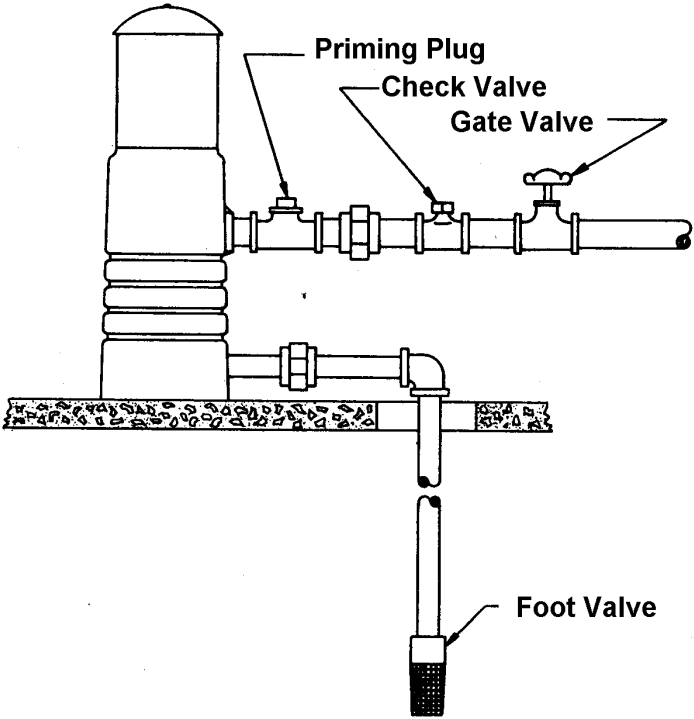
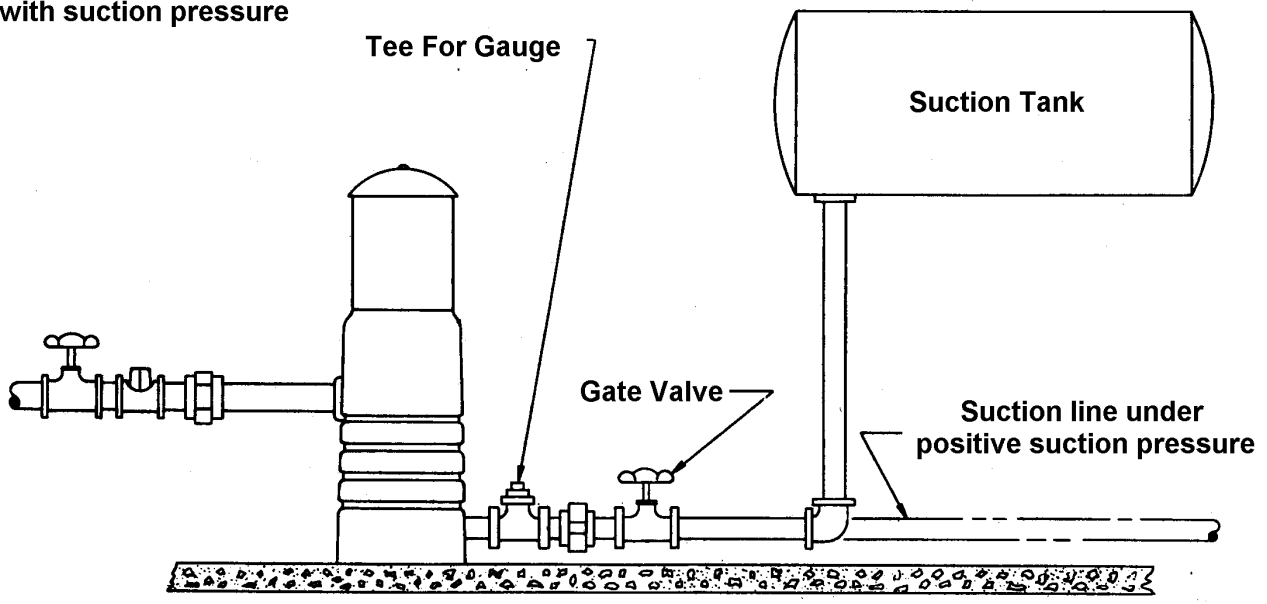

Figure 1
Offset Installation
with suction lift

Figure 2
Offset installation
with suction pressure



Higher temperature and pressure operating limits with a mechanical seal can be attained through the use of special seals, available upon request from Peerless Pump Company at slight increase in cost. Clear water is defined as water with less than 150 PPM total dissolved solids. Chromate treated water above 250 PPM or 180°F. will require special material combinations.

a. Packing

The stuffing box housing contains 2 rings of resilient core metallic packing and 3 rings of dry graphitized plastic packing. Always use metallic packing for the first and last rings. When packing reaches the point where the gland is no longer effective, it is recommended that a new set of packing be installed, rather than adding a new ring of packing. One or two sets should always be carried as spares. A leakage through the packing box of approximately 50 to 60 drops per minute is recommended. Tighten gland bolt nuts finger tight only.

b. Mechanical Shaft Seal

CAUTION Seals must not come in contact with hydrocarbon materials such as: gasoline, oil, propane; or cleaning agents such as: kerosene, lacquer thinner, alcohol, etc.

During normal operation there should be no leakage through the shaft seal. A short run-in may be required when the pump is first placed in operation before perfect sealing is obtained. When the life-time of the seal has been expended, the seal faces become scored and leaks develop. Disassemble the seal housing (refer to disassembly instructions) so that seal may be cleaned, examined, repaired and/or replaced. Check rubber bellows for leaks and seal faces for scratches. The seal housing "O" ring should be checked for cracks or cuts. Worn seal parts should be replaced, but emergency repairs may be made to the seal faces by smoothing these surfaces on No. 500 grit Carborundum paper placed on a sheet of glass plate to give a true surface. It is recommended that one or two mechanical seals be carried as spares.

6. SHAFT SEALING "J" JOCKEY

CAUTION Seals must not come in contact with hydrocarbon materials such as: gasoline, oil, propane; or cleaning agents such as: kerosene, lacquer thinner, alcohol, etc.

This pump has been provided with mechanical shaft seal. Maximum clear water operating conditions are 220 ° F. at 150 psi. See 5b. for additional information.

7. PRIMING INSTRUCTIONS

WARNING Before starting the pump be sure it is completely primed. If the pump is operating under suction lift, it will be necessary to use a tee with a priming plug or similar adaptation to initially fill the case and piping with water (see Figure1). If the

pump is to operate pressure, a priming tap will not be necessary. A pipe plug is furnished on top of the pump motor adaptor to release air from the pump. The shaft coupling should be rotated by hand several times to release all of the air from the pump.

8. ELECTRICAL CONNECTIONS

CAUTION Refer to the motor nameplate, terminal box plate marking, and the wiring within to make sure that the motor matches the power supply characteristics. If the motor is not wired for the voltage available, change the wiring as indicated on the motor wiring diagram. Provide all motors with running overload protection which guards against excessive running current or temperature.

It is recommended that a properly fused line entrance switch be used with all motors to give additional protection.

9. MOTOR ROTATION CHECK

Incorrect motor rotation results in poor pump performance. Rotation must be clockwise when looking down on top of the motor toward the base end of the pump. The rotation of all single phase motors is pre-determined by internal wiring. The rotation of 3-phase motors must be determined at the time of installation. Check the rotation of 3-phase motors by momentarily starting the pump and observing coupling rotation. If the unit has been determined to be rotating incorrectly, interchange any two of the three leads and the rotation will be reversed.

10. STARTING THE PUMP

Prior to start-up, check the lateral position of the shaft and impeller assembly as follows:

- 1) Loosen upper coupling clamp screws.
- 2) Lower shaft and impeller assembly downwards as far as possible.
- 3) Raise the shaft and impeller assembly upwards as far as possible.
- 4) Lower assembly to mid-position of total travel.
- 5) Tighten all coupling clamp screws to 7-8 ft.-lb.

The pump shaft should be turned by hand to make sure it is free and the pump fully primed as instructed in Part 6. All valves in the suction line must be opened and the discharge valve closed. The pump can now be started and when pressure is up, the discharge valve opened to its operating position. NOTE: If the pump is run dry because of improper priming, the wear rings will seize and be ruined, the seal will have to be replaced or the shaft replaced because of damage thru the packing area.

SPECIAL MAINTENANCE INSTRUCTIONS

WEAR RING AND BASE BEARING REPLACEMENT

This pump is equipped with wear rings which fit with close running clearance to impeller hub and skirt. Over a period of years clearance between impeller hub loosens which will reduce head and efficiency of pump. Upon disassembly of pump the wear ring to impeller hub and skirt clearance should be checked. If diametrical clearance exceeds .020", the rings should be replaced. Base bearing must always be replaced when wear rings are replaced.

A. WEAR RING AT IMPELLER HUB

Each diffuser casing has one of these wear rings which may be either pressed or cut out. Use care not to damage the bored surface of the diffuser stage. Note that one end of the new wear ring has a chamfer on its bore. This end must be installed toward the base end of the pump. The end of the wear ring toward the base end of the pump must be flush with the side toward base of the diffuser casing bore into which it presses. If this is not done and wear ring is pressed beyond the side of the diffuser casing bore toward base of pump, lateral movement (end play) will be lost in shaft and impeller assembly when pump is reassembled. Avoid wear ring distortion by evenly pressing the wear ring into diffuser bore.

B. WEAR RING AT IMPELLER SKIRT

The pump base and each diffuser casing has one wear ring to accommodate the impeller skirt which may be either pressed or cut out. Use care not to damage the bore into which the wear ring is pressed. Note that one end of the wear ring is chamfered. This end of the wear ring must be assembled toward the motor adapter end of the pump. This end of the wear ring (toward motor adapter) must be installed flush with the diffuser casing bore into which it is pressed. Again, as in Part A, if this is not done and wear ring extends out beyond diffuser casing bore, there will be a loss of lateral movement. Avoid wear ring distortion by pressing the ring evenly into its bore.

C. BASE BEARING

The pump base must be disassembled from the pump as per Disassembly Instructions. The plug on the bottom of the base must be removed. The base bearing can now be pressed from the base spider. If "O" ring on base plug is cracked or cut, replace with new part.

Replace the plug on the bottom of base and tighten securely. The new base bearing can now be pressed into base spider until the bearing contacts the top of the base plug. Reassemble base and pump as per Reassembly instructions.

REPLACEMENT OF SHAFT SEAL

1. To replace the shaft seal it is not necessary to disturb the piping. Proceed per Disassembly Instructions Steps 1 thru 5.
2. Open the air vent plug in the motor adapter to relieve the internal water pressure.
3. Remove the four cap screws which retain the seal housing or stuffing box housing to motor adapter.
4. If packing is used, refer to Installation and Operation Instructions Part 5A, Disassembly Step 7 and Reassembly Step 14.
5. If seal is mechanical type, refer to Installation and Operation Instructions Part 5B and Disassembly Step 8. If replacement of stationary sealing ring and "O" ring gasket is necessary, pry out with screwdriver and replace with new ones. Do not use oil for lubrication. Refer to Reassembly Instructions Step 15 for recommended lubricants and reassembly of entire mechanical seal. Do not use metal tools which will scratch sealing faces of seal.
6. To reassemble motor on pump and to re-start, refer to Reassembly Instructions Steps 16 thru 21.

Temperature and Working Pressure Limitations	
MECHANICAL SEAL	
TEMPERATURE °F	MAXIMUM WORKING PRESSURE PSI
0-180	200
180-225	150
226-250	50
PACKED	
0-230	200

ITEM NO.	PART DESCRIPTION	MATERIAL
2	Adapter	Cast Iron
3	Shaft Coupling	Steel
4	Stuffing Box	Cast Iron
5	Packing Set	Graphited Braded Fiber, Graphite Impregnated
6 & 27	"0" Rings	BUNA-N Rubber
7	Shaft	416 Stn. Steel
8	Diffuser	Cast Iron
9 & 12	Diffuser Rings	Bronze
10	Impeller	Bronze
11	Gasket	Fiber
13	Pump Base	Cast Iron
15	Base Bearing	Bronze
20	Gland Clamp	18-8 Stn. Steel
21	Packing Gland	Bronze
22	Gland Stud	Steel
24	Tie Stud	Steel
25	Drive Lock Pin	416 Stn. Steel
28	Base Plug	Brass
29	Mech. Seal Housing	Cast Iron
31	Mechanical Seal	EPT Bellows & Seat "0" Ring Carbon Washer Brass Metal Parts Ni-Resist Seat 18-8 Stn. Stl. Spring
32	Mechanical Seal Spacer	Brass

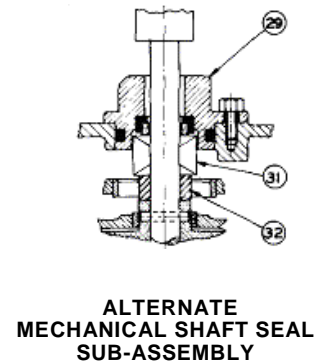
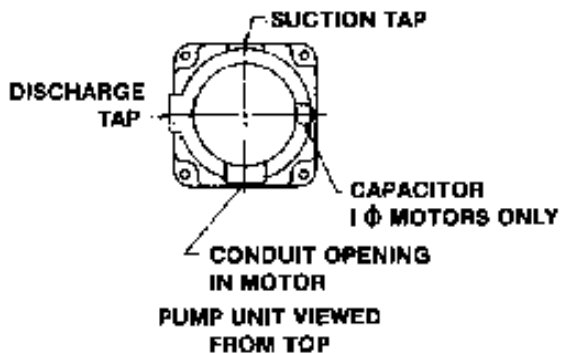
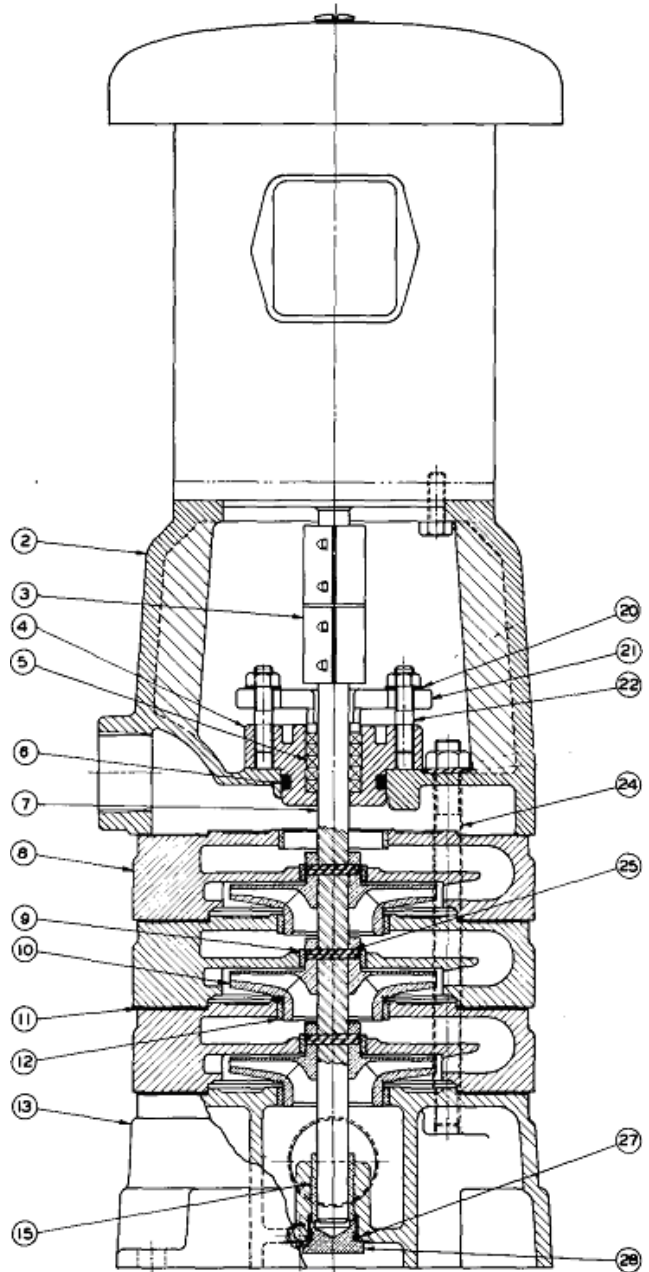

DISASSEMBLY

Before proceeding, check "Pump Troubles" on page 11 to insure that disassembly is necessary.

Refer to cross-section drawing 2892550 on page 6.

1. Open the disconnect switch. Close the valve or valves in the suction and discharge lines and drain the pump. Use the drain plug shown as 16.
2. Remove four cap screws which hold the motor to the motor adapter (item 2, drawing. 2892550). If the pump has an additional supplementary adapter plate between the motor and standard motor adapter, remove cap screws securing supplementary adapter to standard motor adapter instead of cap screws between motor and supplementary adapter.
3. Loosen the clamp screws in coupling (Item 3, drawing. 2892550).
4. Motor is now ready to be removed. Taking care not to bend either the motor shaft or the pump shaft, re-move the motor from the pump by lifting motor straight up.
5. Remove coupling from pump shaft.
6. Remove the four cap screws (30) which retain the seal housing or stuffing box housing (29 or 4).
7. If the pump has the packing type seal, remove the nuts (19) from the gland bolts and gland clamps and remove gland (21). Lift the stuffing box housing (4) off the shaft.
8. If pump has a mechanical seal, lift the seal housing (29) off the pump shaft. Note that the "O" ring and the stationary half of the shaft seal are removed with the seal housing unless they are to be replaced (see Part 5B of Installation and Operation Instructions and Special Maintenance Instructions for Shaft Seal Re-placement Step 5). Reach into motor adapter cavity and slide rotating shaft seal half (31) and the seal spacer (32) off the pump shaft.
9. Remove the four stud nuts (23) and sealing washers (38) on motor adapter.
10. Using a soft faced hammer, tap the motor adapter (2) and top diffuser (8) to loosen the gasket seal. Remove motor adapter off the top diffuser casing stage.

11. Remove top diffuser gasket, top diffuser casing and second diffuser gasket.
12. Using soft faced hammer, tap pump base (13) to loosen gasket seal between base and bottom diffuser casing. Pulling steadily and carefully, remove base with four studs attached from diffuser casing stack.
13. Remove bottom gasket.
14. To disassemble diffuser casing stack, first level stack with 2 x 4 block under hub of top impeller and thin wood under diffuser stack as required. Shaft and impeller hub should not be supporting any weight of the diffuser stack. Impeller hub should just be resting on edge of 2 x 4 block. Using 5/32" or 1/8" needle punch, drive lock-pin out of impeller hub and shaft (see Figure 3).
15. Remove top impeller and the next diffuser casing (#2) and diffuser gasket (#3) using soft faced hammer if necessary to break gasket seal.
16. Repeat steps 14 and 15 until the last impeller has had its lock-pin driven out and the impeller removed from the shaft.
17. If base bearing is to be replaced, refer to Special Maintenance Instructions Part C.

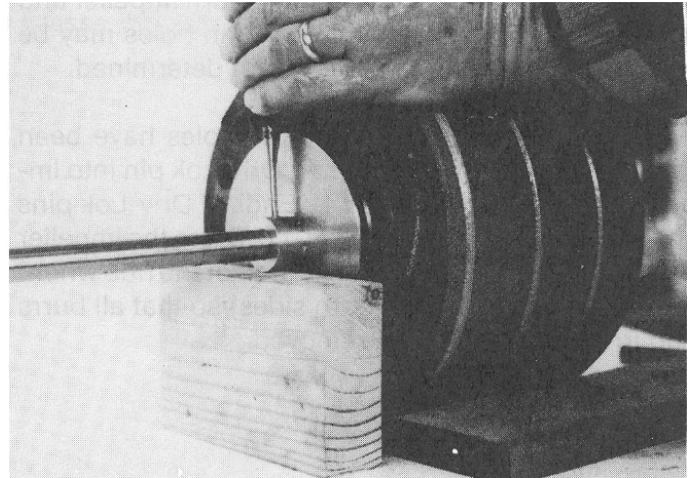

Figure 3

REASSEMBLY

1. Before starting, clean and inspect all parts. New stage gaskets should always be used in all reassemblies. Gaskets may be cut from 1/32" material such as Garlock Blue-Gard r Style 3200, an equivalent, or purchased ready cut from Peerless Pump Company distributors and dealers.

2. Place the pump shaft into the base bearing; the pump shaft will butt and stop at the base plug. It may be necessary to rotate the pump shaft to eliminate an air pocket between the base plug and the pump shaft if the shaft does not butt readily.

3. Place first impeller on pump shaft so that hub is facing toward top end of shaft and impeller skirt is facing bottom end of shaft. Slide impeller toward the bottom until the lock-pin hole in the impeller hub is lined up with the first (bottom) lock-pin hole in the shaft. Next place impeller and shaft on 2 x 4 block so that impeller hub is resting on edge of 2 x 4 block (see Figure 4). Check the alignment of the lock-pin hole in impeller hub and the lock-pin hole in pump shaft before proceeding and adjust as necessary. Now place Driv-Lok pin with pilot end (taper) in impeller lock-pin hole and using a standard punch and hammer, tap the Driv-Lok pin into final position taking care while doing so that alignment between impeller and shaft is not lost. If resistance is encountered after Driv-Lok pin has made some initial headway, alignment has been lost. Turn impeller and shaft so that opposite end of lock-pin holes may be seen and adjustment of realignment determined.

When impeller and shaft lock-pin holes have been realigned, proceed with tapping Driv-Lok pin into impeller and shaft (see Figure 4). Ends of Driv-Lok pins should be 1/32" below hub surface. Dress the impeller hub lightly with a file on that portion of the hub where lock-pin hole is located (both sides) so that all burrs and irregularities may be removed.

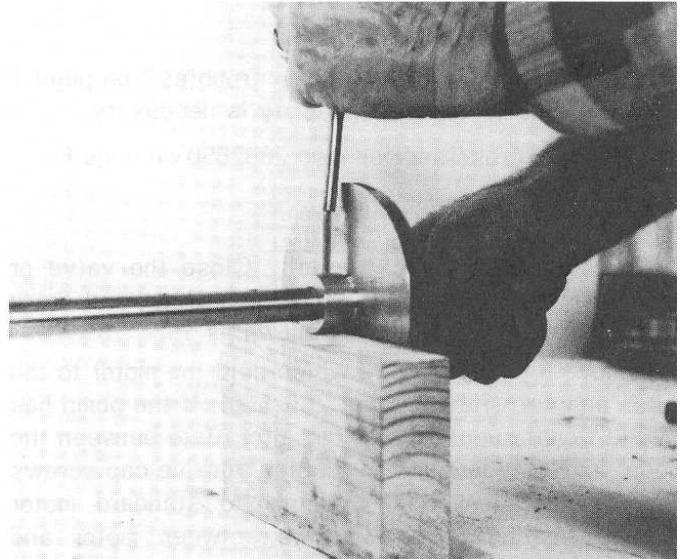

Figure 4

4. Place a diffuser casing on pump shaft with the cavity of the diffuser facing the impeller. Slide diffuser casing toward the impeller until the diffuser casing is positioned with the impeller inside the diffuser casing cavity.

5. Place another impeller on shaft with impeller skirt facing diffuser casing and impeller hub facing top end of shaft. Slide impeller toward diffuser casing until impeller skirt slips into diffuser casing wear ring. Line up lock-pin hole of new impeller hub with corresponding lock-pin hole of the shaft. At the same time

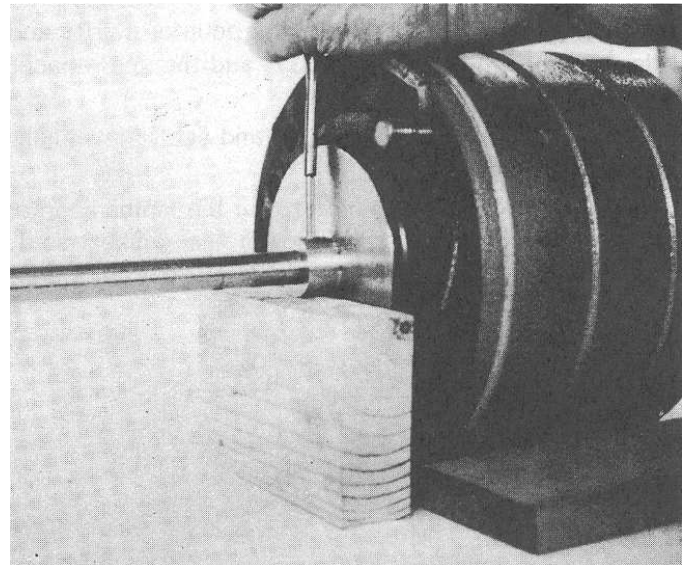

Figure 5

place 2 x 4 block on edge under impeller hub and level shaft and diffuser casing with the addition of thin wood under diffuser casing or 2 x 4 block as necessary and as instructed in Disassembly Step 14 (see Figure 5). Proceed to tap a Driv-Lok pin into impeller hub and shaft as directed in Reassembly Step 3.

6. Remove one of the four stud bolts in pump base and place into one of the diffuser casing stud holes. The longer threaded end should face toward the top end of the shaft (see Figure 5). The purpose of this is to keep all subsequent diffuser casings and gaskets lined up.

7. Place a diffuser gasket on the top end of the diffuser casing (end facing top of shaft) and the stud bolt. The cut out sections on the gasket should match the corresponding sections cast into the diffuser casing. All gaskets should be dipped in water or greased prior to installation.

8. Proceed as instructed in Reassembly Steps 3, 4, 5, 6 and 7, until all impellers have been secured to the pump shaft and top diffuser and diffuser gasket have been placed.

9. Replace the three remaining stud bolts on the pump base if these were removed during disassembly.
NOTE: The end of the stud with the shorter threaded section screws into the base.

10. Place a diffuser gasket on pump base and position pump base on diffuser casing stack by sliding the stud bolts into the diffuser stud bolt holes (see Figure 6). While doing so, make certain that the cut out sections of the diffuser gasket match the corresponding sections cast into the bottom diffuser casing.

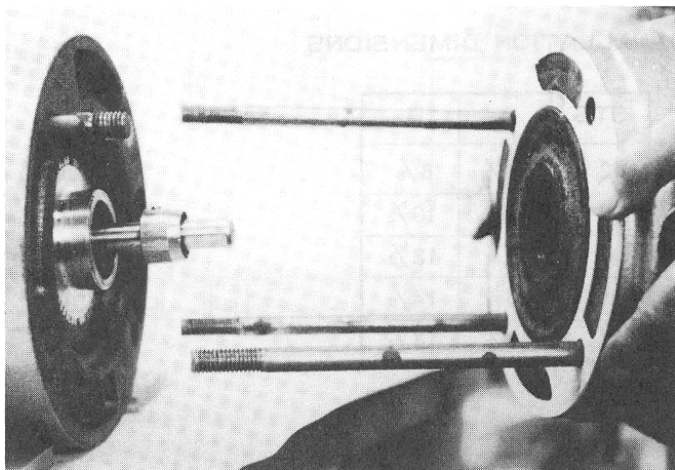

Figure 6

11. Screw the fourth stud bolt which was used to keep diffuser casings and gaskets lined up into pump base.

12. Place the motor adapter over the studs and down onto the gasketed top diffuser stage. Place four sealing washers over studs and finger tighten the four stud nuts while tapping adapter and all diffuser casings lightly all around pump with soft faced hammer to make certain they are all seating properly. At this point check the end play movement of shaft and impeller assembly. There should be 3/32" to 3/16" end play movement depending on the number of stages. If there is little or no lateral movement available, it will be necessary to disassemble pump in order to determine cause of trouble. Normally the trouble is due to an impeller skirt or wear ring which is damaged. Another common occurrence is forgetting to dress an impeller hub as instructed in Reassembly Step 3. Still another possibility is a diffuser gasket which is not placed properly on the register of a diffuser casing, thus preventing that stage from assembling properly with the next stage.

13. If the pump has a packing type seal, inspect "O" ring found on skirt of stuffing box housing. If damaged, replace. Secure stuffing box to motor adapter with four cap screws. For assembly of packing rings refer to Installation and Operation Instructions Part 5A.

14. **CAUTION** Mechanical seals are supplied with CRANELAST® material. No oil may be used in the installation of these seals. To facilitate reassembly, "MOLYCOTE®" 3%, detergent solution, mild soap solution, glycerin, ethylene glycol, or silicone grease such as DC No. 55 may be used as an installation lubricant. If pump has a mechanical type seal, slide the seal spacer on the shaft into place in seal cavity. Next, slide the rotating half of the shaft seal on the shaft into place in seal cavity. Apply recommended lubricant on the shaft to facilitate sliding. The spring retainer portion of the seal half must be in down position. The "O" ring seal on the skirt of the seal housing must be checked to insure that the surface has not been damaged or marred. If it has, replace with new part. Next, place seal housing (with stationary seal parts in place) over the pump shaft and down onto motor adapter. Secure the seal housing to the motor adapter by replacing the four seal housing cap screws.

15. Place coupling onto pump shaft so that shaft extends approximately halfway through coupling bore. Lightly tighten coupling clamp screw over pump shaft.

16. Prior to replacing the motor, remove all burrs from the motor shaft extension.

17. After the motor has been placed on top of the pump replace and tighten the four motor to motor adapter cap screws.

18. Using a screwdriver as a lever between the stuffing box housing or mechanical seal housing and the bottom of the coupling, raise the shaft and impeller assembly up as far as possible and then lower to mid-position of the total travel. Holding the coupling in this desired position, tighten the coupling clamp screws.

19. Using a soft faced hammer to tap the motor adapter and diffuser stages, rotate the coupling by hand until running member turn freely.

20. Alternately tighten the four stud nuts until tight. Torque to 60 ft.-lbs. Tighten gland bolt nuts with fingers if pump is packing seal type. The pump is now ready to be primed. Follow Installation and Operation Instructions for Priming. Electrical Connections, Starting, Motor Rotation check and Final Shaft Sealing if pump is packing seal type.

RECOMMENDED SPARE PARTS

1. Complete set of gaskets – one required per stage plus one.
2. Impeller Driv-Lok pins – one per stage.
3. Packing Seal Type:
 - A. Two sets of packing.
 - B. "O" ring – for stuffing box housing.
5. In some instances, depending on application, it is desirable to stock complete components for one stage. This will reduce time required to get pump back in service.
6. Four sealing washers.

NECESSARY INFORMATION

In order to give quick and accurate service when ordering spare parts, the following should be submitted:

1. Pump size and type as noted on nameplate.
2. Pump serial number a noted on nameplate.
3. The name and number of the parts as shown on the section drawing.
4. Quantity required of each item.

The Sales Engineer or authorized Distributor will be available to help in planning a repair parts stock program with you.

INSTALLATION DIMENSIONS

STG	A	B
2	30.50	8.66
3	32.44	10.59
4	34.38	12.52
5	38.00	14.44
6	39.94	16.37

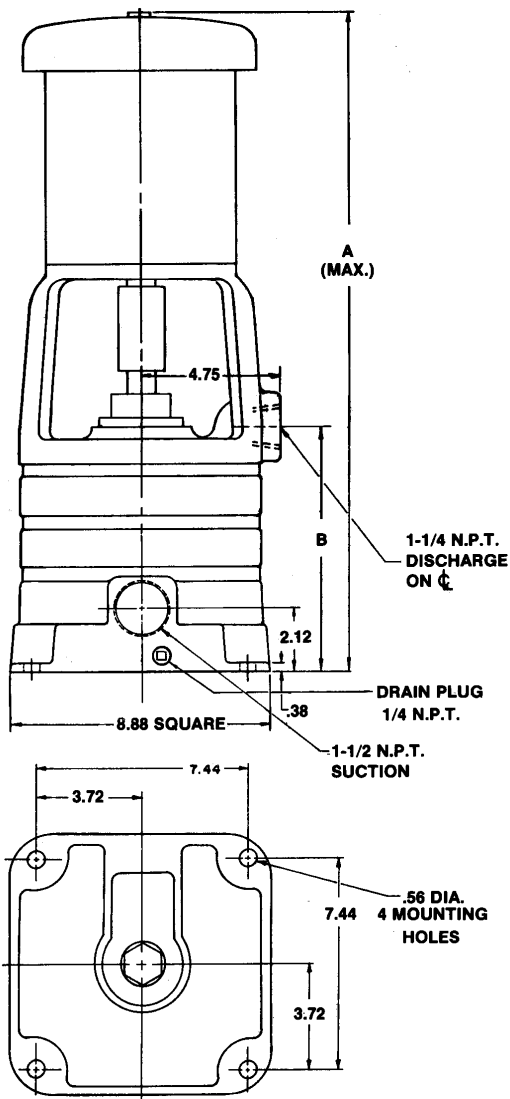

Drawing. No. 2887910

PUMP TROUBLES

FAILURE TO DELIVER RATED HEAD OR CAPACITY

1. Not up to speed.
2. Pump not primed.
3. Air leaks in suction line.
4. Incorrect rotation.
5. Discharge head above pump's rating.
6. Impeller clogged or damaged.
7. Foot valve too small or restricted at entrance.
8. Excessive suction lift. Check performance curve with Peerless Pump Company Distributor for pump's NPSH requirements.
9. Worn wear rings and impellers cause increased leakage through rings.

OVERLOAD ON MOTOR OR DRIVER

1. Speed higher than rated.
2. Total head lower than rating; i.e., pumping too much water.
3. Liquid handled is of higher specific gravity or viscosity than that for which pump was designed.
4. Mechanical Trouble – of pump or driver.

PUMP VIBRATES OR IS NOISY

1. Insufficient or insecure foundation.
2. Impeller partially clogged causing an unbalanced condition.
3. Mechanical defects; bent shaft; binding or rotating elements; worn rings.
4. Suction or discharge pipe not anchored.
5. Suction lift too high.
6. Vapor bound – not fully primed (pump is noisy).



Peerless Pump Company

P.O. Box 7026-Indianapolis, IN 46207-7026
Phone: (317) 925-9661-Fax: (317) 924-7288