

Variable speed drives Size 2A Vertical Hydroconstant®

Instructions

- Installation
- Operation
- Maintenance

Read this entire book

before attempting to install, operate or repair this drive. Properly installed, your Peerless Pump variable speed drive will give you satisfactory, dependable service. We urge that you read carefully these step-by-step instructions, to simplify any problems of installation, operation or repair.

Failure to read and comply with installation and operating instructions will void the responsibility of

the manufacturer and may also result in bodily injury as well as property damage.

This book is intended to be a permanent part of your drive installation and should be preserved in a convenient location for ready reference. If these instructions should become soiled obtain a new copy from Peerless Pump. Include drive size, and/or serial number with your request.

WARRANTY

New equipment manufactured by Seller is warranted to be free from defects in material and workmanship under normal use and service for a period of one year from date of shipment; Seller's obligation under this warranty being limited to repairing or replacing at its option any part found to its satisfaction to be so defective provided that such part is, upon request, returned to Seller's factory from which it was shipped, transportation prepaid. This warranty does not cover parts damaged by decomposition from chemical action or wear caused by abrasive materials, nor does it cover damage resulting from misuse, accident, neglect, or from improper operation, maintenance, installation, modification or adjustment. This warranty does not cover parts repaired outside Seller's factory without prior written approval. Seller makes no warranty as to starting equipment, electrical apparatus or other material not of its manufacture, since the same are usually covered by warranties of the respective manufacturers thereof.

In the event, notwithstanding the terms of this agreement, it is determined by a court of competent jurisdiction that an express warranty has been given by Seller to Purchaser with respect to the head, capacity or other like performance characteristics of said equipment, Seller's liability for breach of the same shall be limited to accepting return of such equipment F.O.B. plant of manufacture, refunding any amount paid thereon by Purchaser (less depreciation at the rate of 15% per year if Purchaser has used equipment for more than thirty (30) days) and cancelling any balance still owing on the equipment.

THIS WARRANTY IS EXPRESSLY IN LIEU OF ANY OTHER WARRANTIES, EXPRESSED OR IMPLIED, AND SELLER SPECIFICALLY DISCLAIMS ANY IMPLIED WARRANTY OF MERCHANTABILITY OR FITNESS FOR A PARTICULAR PURPOSE.



LaBour
Taber

Peerless Pump Company
2005 Dr. Martin Luther King Jr. Street
Indianapolis, IN 46202
Phone: (317) 925-9661 • Fax: (317) 924-7388

SA), Inc.

4849500

IMPORTANT SAFETY PRECAUTIONS

Pump parts, Hydroconstant drives, and the tools and rigging equipment used in installation are heavy and may easily cause personal injury if dropped or carelessly handled. The normal precautions and safety rules associated with the erection of heavy machinery, in regard to manual lifting, use of power equipment, and handling of tools, must be observed in the installation of this drive.

Petroleum-base cleaning solvents are flammable. Open flame or smoking by personnel in the vicinity of these solvents is extremely hazardous and must not be permitted.

Do not work under a heavy suspended object unless there is a positive support under it to stop its fall in

event of sling or hoist failure. Disregard of this warning could result in grave personal injury.

Before opening the conduit box of an electric motor, be certain that the current to the motor is shut off. An electrical shock from contact with live motor leads can be fatal.

Before attempting repairs to drive or pump open the disconnect switch to electric motor. This prevents accidental running of pump motor. Starting motor during pump repair activities could damage pump and may cause personal injury.

INTRODUCTION

WARNING

The drives described in this bulletin must not be installed in any manner except as specified herein, and must not be operated at speeds, horsepower loads, or temperatures other than those specified when the drive was assembled by the factory. Failure to limit operation of the drives to the conditions specified could damage the drives and may cause malfunction or damage of interconnected equipment. Violation of this warning will void the warranty and may result in serious property damage or grave personal injury.

ALLOWABLE LOADS

Size 11A Fluid Coupling
Models VC, VS & VH

MOTOR SPEED	MOTOR Hp., Max	MOTOR KW., Max
1450 RPM	30	25
1750 RPM	50	40

Size 9A Fluid Coupling
Models VC, VS & VH

MOTOR SPEED	MOTOR Hp., Max	MOTOR KW., Max
1750 RPM	15	10
2900 RPM	75	50
3500 RPM	100	75

UPON RECEIPT OF HYDROCONSTANT DRIVE:

Check carefully to see that all of the equipment has been received. Report immediately any shortages or damages to the transportation company handling the shipment, noting the extent of the damage or shortage on the freight bill and bill of lading.

Do not leave the unit exposed to weather or construction hazards. The drive may become mechanically damaged. This drive is a well designed

and carefully manufactured unit. It should be given the same attention accorded to any precision machine.

The satisfactory operation of a pump and drive depends to a large extent upon proper installation. These instructions cannot answer every question that may arise as each installation will be different. The installer and the operator of this equipment must use good judgement to adapt these procedures to the installation.

DESCRIPTION: The Hydroconstant drive consists of a fluid coupling which is designed to allow continuous, smooth variance of output shaft speed in direct response to a fluid pressure signal as may be generated by a centrifugal pump connected to the coupling. The coupling input shaft rotates at the relatively constant speed of an electric motor. The basic operating sequence is described as follows: Fluid pressure acts through the control mechanism to regulate the coupling output speed. The control mechanism varies the amount of oil, supplied by a gear pump, admitted to the coupling. As the oil continuously flows from the coupling through fixed orifices, admission of more oil increases output shaft speed, less oil reduces output shaft speed. Stabilizing the pressure signal to the control mechanism will fix the output shaft speed at a preselected ratio (always less than one) of the input speed.

WARNING

Hydroconstant drives and pumps weigh several hundred pounds. Do not work under a heavy, suspended object unless there is a positive support under it to stop its fall in the event of sling or hoist failure. Disregard of this warning could result in grave personal injury.

A SUGGESTED METHOD OF LIFTING VERTICAL HYDROCONSTANT DRIVES

Remove motors from VH and VS models before lifting to reduce weight and to increase stability of the suspended drive. Weights to be lifted can be found on the job outline drawing, or may be obtained from Peerless Pump Indianapolis factory.

Use only 1/2-13 UNC thread, drop forged eyebolts conforming to specifications and requirements of ANSI B18.15, installed in opposite corners of the drive housing. Make sure that the eyebolts are threaded into the housing a minimum length of .69 inches (17.5 mm).

Lifting lines attached to the eyebolts must share the total load equally, with lift action passing thru the center axis of the threaded eyebolt shank (0° lifting angle). The use of a properly designed spreader bar is suggested as a means to accomplish this lifting requirement.

Steady lines must be connected to the motor when lifting VC models. Provide for equalized tension on steady lines. NEVER lift the combined weight of a motor and drive by the motor lines alone. Smaller motor frames are incapable of supporting this combined weight. ALWAYS provide steady lines to the motors. Heavy motor frames can pivot the system in mid-air. NEVER try to lift a drive with the pump discharge head, column, or any other driven equipment attached to the drive housing.

A slow lift is always recommended with a maximum acceleration limit of 1.5 G. Similar methods of rigging or lifting may be employed by skilled and qualified riggers to reduce, or equal, similar lifting stress limits. NEVER reach or stand under the Hydroconstant drive, or the motor, or the combination while lifting is in progress.

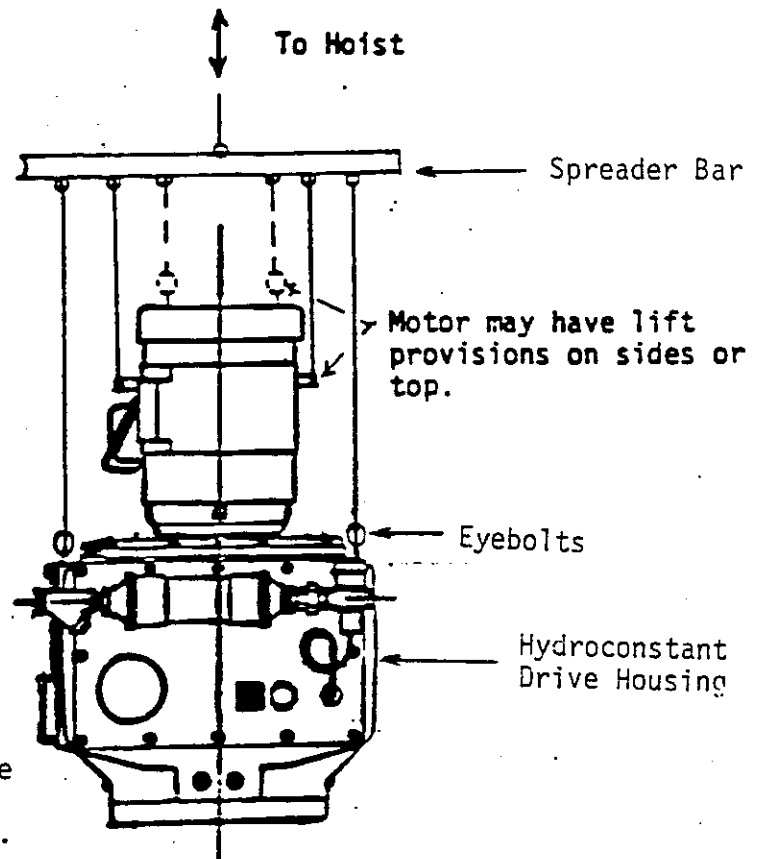

INSTALLATION

WARNING

Do not work under a heavy, suspended object unless there is a positive support under it to stop its fall in event of sling or hoist failure. Disregard of this warning could result in grave, personal injury.

LOCATION:The Hydroconstant unit should be installed in a clean, well-drained and ventilated area, and be accessible for inspection and proper care. Ample room should be provided for installation and removal. Be sure the space is vented to the outside atmosphere to avoid a rise of ambient temperature and collection of any oil vapor. Refer to bulletin furnished with pump for instructions for mounted units installation.

These cover the following:

- (A) Foundation
- (B) Mounting
- (C) Alignment (piping)
- (D) Grouting
- (E) Piping

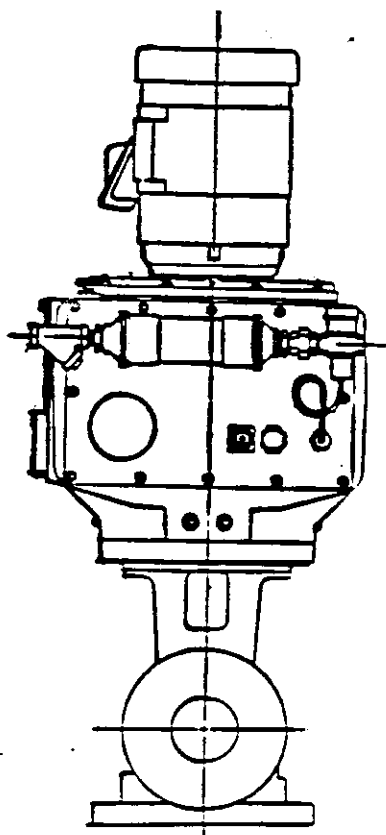

Figure 1. Model VC Hydroconstant with close coupled motor and vertical turbine pump.

WARNING

Before making electrical connection to control panel, be certain that the power supply is turned off and that the disconnect switch is open. Disregard of this warning could result in fatal electrical shock.

ELECTRICAL CONNECTIONS: Select a convenient location and hang or footmount the electrical panel. Connect power supply to the panel, and make interconnections between panel and motor in accordance with the schematic wiring diagrams supplied with the unit. All work must conform with national and local codes. Line voltage and wire capacity must match the ratings stamped on the electrical panel nameplate.

NOTE: Only items listed in job order are furnished by Peerless Pump.

WARNING

Use only qualified personnel (riggers) to lift or move vertical Hydroconstants.

NEVER lift vertical Hydroconstants using hooks or slings on shafts.

NEVER place eyebolts in tapped holes except for removal of a part to perform service work.

NEVER lift pump assemblies with vertical Hydroconstants attached.

Disregard of this warning can result in grave, personal injury and death.

CAUTION: Foundation must be firm, level and strong enough to support entire weight of vertical Hydroconstant and pump assembly without deflection. The foundation must be in full contact with machined bottom of discharge head.

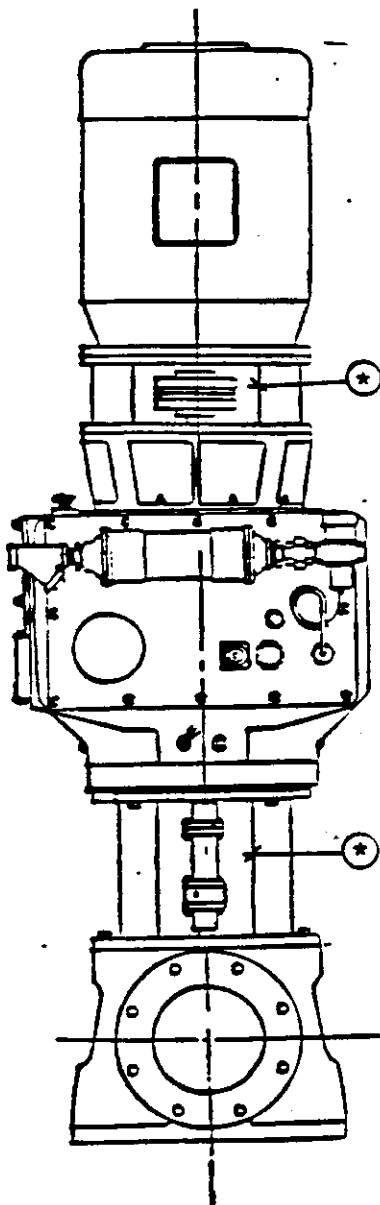

Figure 1(a)

Model VS, Vertical
Solid Shaft Motor

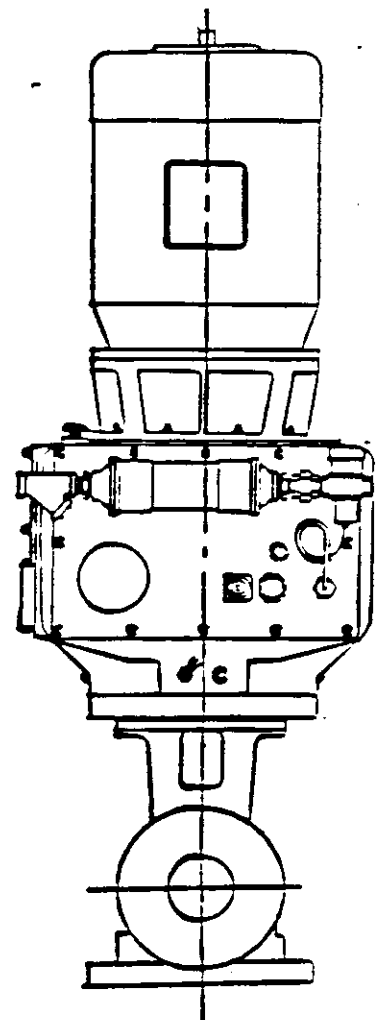

Figure 1(b)

Model VH, Vertical
hollow shaft motor
& Peerless 4x4x10C
discharge head.

Figures 1(a & b) both show vertical Hydroconstants with external coupled motors. Figure 1(a) shows a spacer output shaft coupling arrangement. Figure 1(b) shows a socket type shaft coupling arrangement. See Figures 1(d) and 1(e) for output shaft coupling details.

Warning: Coupling guards must be installed in designated locations (*) before start-up. Guards must be in place at all times when motor is running. Disregard of this warning may result in serious personal injury or death.

Caution: Use SAE GR. 8 (high strength steel) bolts with shaft coupling assembly. Do not indiscriminately substitute different grades of bolts.

Note: Discharge heads other than Peerless 4x4x10C will require a yoke (adapter) between it and the vertical Hydroconstant.

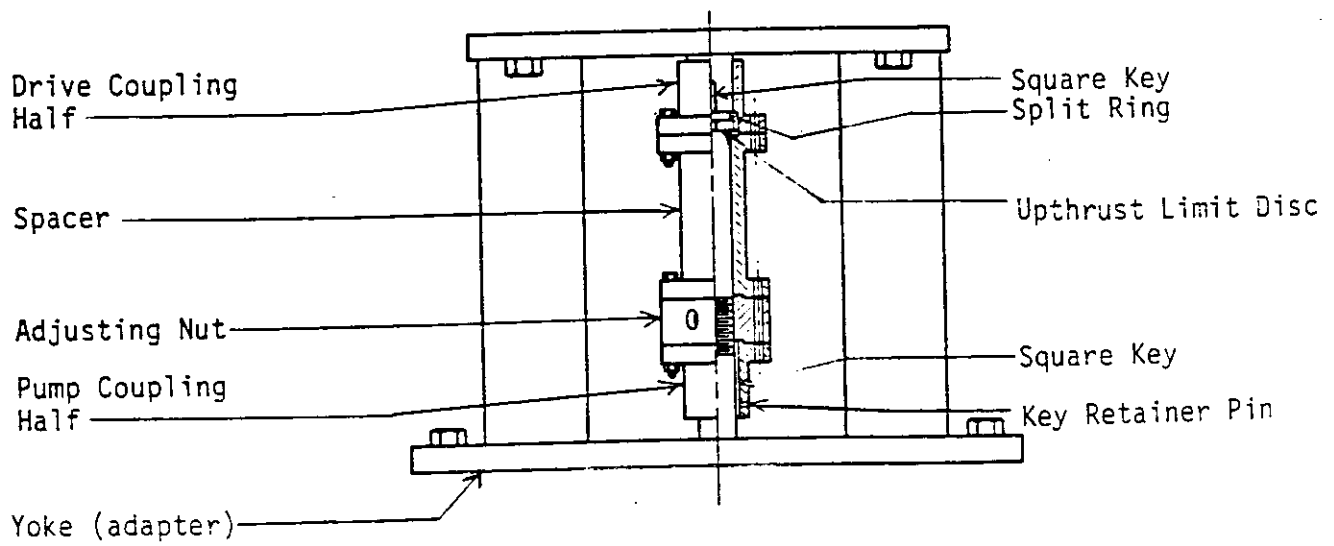
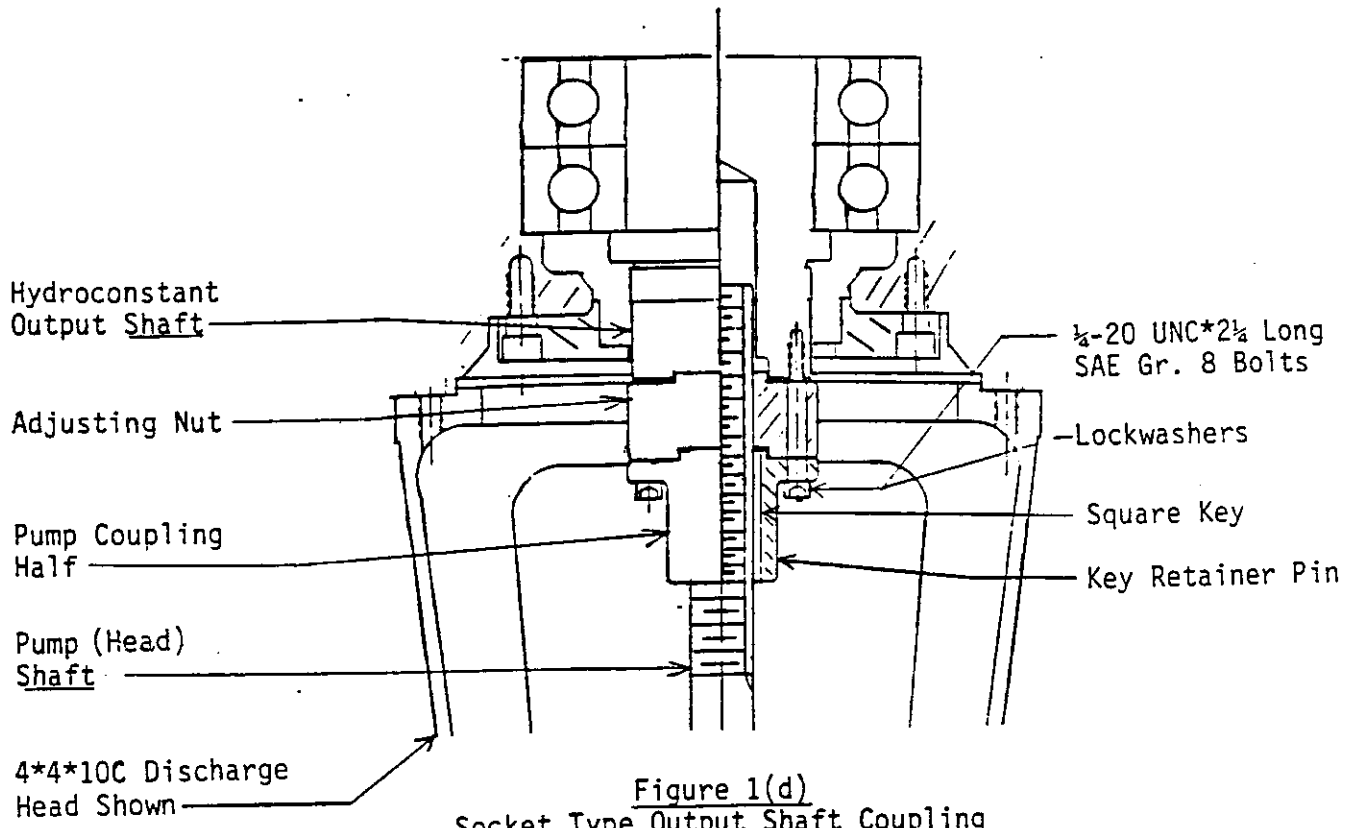

Pump Shaft Lateral:

Top column shaft on all Peerless vertical turbine pumps must be raised 1/16 to 1/8 inch (1.5 to 3 mm) from resting position. Refer to and read section in pump instruction manual pertaining to the proper setting of shaft lateral.

- A. Turn adjusting nut - Fig. 1(d) or 1(e) until gap between it and output shaft (or spacer) is equal to specified lateral setting.
- B. Replace shaft coupling bolts. Raise column shaft by tightening shaft coupling bolts. Tighten shaft coupling bolts to within: 84-90 in-lb. for 1/4-20UNC bolts, 168-178 in-lb. for 5/16-16UNC bolts.
- C. Check for free rotation of pump shaft without drag. Deeper setting pumps may have to be adjusted again with wider gap to allow for normal lateral and shaft settling.
- D. Insufficient or excessive lateral adjustments will cause the top column shaft to bind. Recheck and reset lateral.

Heat Exchanger Water Supply:

- A. Clean cooling water at 10 psig minimum pressure (70 k.pa.), 125 psig maximum pressure (860 k.pa.) must be provided to heat exchanger.
- B. Use pipe size adequate to support a minimum flow rate of 1 USGPM (.3 m³/hr.) for each 10 HP (7.5 kw) increment of drive motor used.
- C. Closed loop heat exchanger systems (cooling water returned to suction pipe, well or other main source) cannot be used for human or animal consumption, or in any application where oil contamination of pumped liquids can create problems, or where prohibited by local codes. If this method is employed, a check valve must be used between the water modulating valve (7, Fig. 3) and the return location. A thermal safety valve set for 85°F (30°C) must be installed on the discharge head.

Outdoor Installations:

- A. If the drive is exposed to freezing temperatures during periods of inactivity, water may freeze and burst heat exchangers, connecting lines, hydraulic pressure controls (1, Fig. 3) and sensing lines. Consult with factory on protection or provide for drive shutdown and complete drainage of all water.
- B. Normally supplied air breather (11, Fig. 3) is not designed to filter dust. If drive is exposed to dust laden atmosphere, oil contamination can occur which will destroy bearings and oil seals. Consult with factory on protection.

Prevention of Pump Backspin:

If pump backspin can occur, an automatic start system panel must be provided with a timed, restart lockout. Mechanical anti-reverse ratchets are not available on drive. Do not rely on check valves in pump discharge lines for prevention of backspin.

SPEED CONTROL CONNECTIONS:

A. Hydraulic Control;

Connect a 1/2 inch (12 mm) I. D. pressure sensing line between pump discharge (manifold on downstream side of check valve) and the pressure control (1, Fig. 3). Make or furnish provisions for bleeding entrapped air from pressure sensing lines. Connect only to straight sections of discharge pipe away from fittings and flanges.

B. Pneumatic Control;

Connect a 1/2 inch (12 mm) I. D. air line to pressure control (1, Fig. 3). Pump drive shaft will reach maximum speed at low air pressure and minimum speed at high air pressure.

C. Electric Control;

Read instructions furnished with system controller (control panel). Solenoid (3, Fig. 5) must be connected to system controller according to furnished wiring diagram. Voltage control range is from 0 to 12 V.D.C. Pump drive shaft will reach maximum speed at low end of voltage control range and minimum speed at high end of voltage control range.

Thermal Cutout Switch:

The thermal cutout switch is a high temperature protective device. Its use is highly recommended because prolonged operating temperatures in excess of 155°F (68°C) will decrease effective operating life of bearings and oil seals.

- The white and yellow lead wires form a normally closed connection. Connect in series with motor starter coil in control panel.
- The white and brown lead wires form a normally open connection. Connect to an alarm or indicator light.
- Enclose all three lead wires in water proof or explosion proof conduit.
- The thermal cutout switch is present to trip (change electrical connections) when operating temperature exceeds 155°F (68°C). The thermal cutout switch will reset automatically when oil temperature drops to about 140°F (60°C)

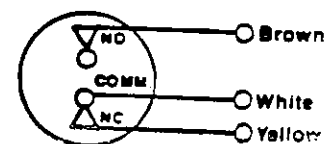
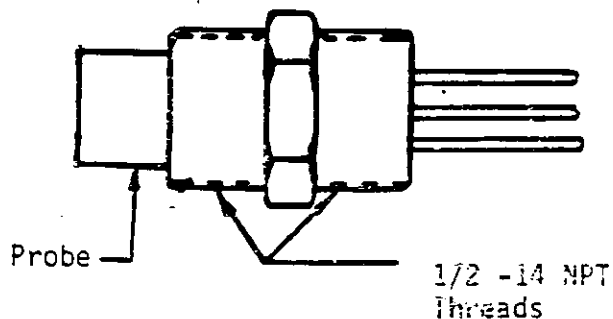

Figure 2(a) Wiring Diagram

Figure 2. Thermal Cutout Switch

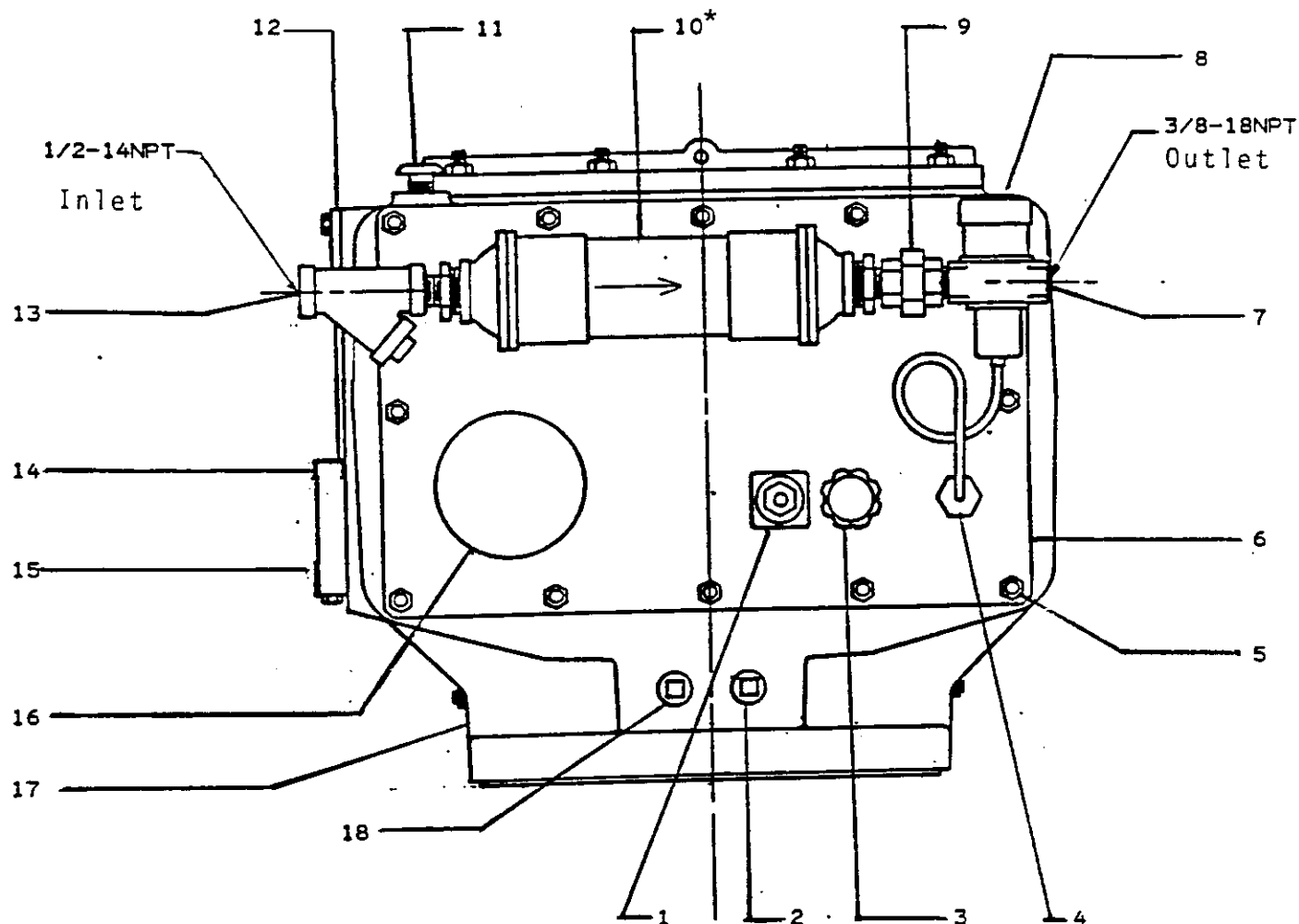

Figure 3.

Control Plate with Arrangements For Hydraulic Control

- | | |
|--|--|
| 1. Pressure Control $\frac{1}{4}$ x18NPT | 10. Heat Exchanger (single pass shown) |
| 2. Magnetic Pipe Plug | 11. Air Breather |
| 3. Pressure Adjustment Knob | 12. Access Plate |
| 4. Water Regulator Probe | 13. Water Strainer |
| 5. Hex Head Nut 3/8 X 16UNC | 14. Oil Level Gauge |
| 6. Control Plate Gasket | 15. Thermometer |
| 7. Water Modulating Valve | 16. Oil Filter |
| 8. Temperature Adjustment Knob | 17. Housing (Hydroconstant) |
| 9. Union 3/8 X 3/5 Pipe | 18. Thermal Cutout Switch |

* Double pass heat exchangers furnished on 50Hp (40KW) and above systems.

CAUTION: If cooling water supply is taken from pump discharge and hydraulic control is used, make sure pressure sensing line and heat exchanger water supply are taken from separate locations. This will help avoid control problems.

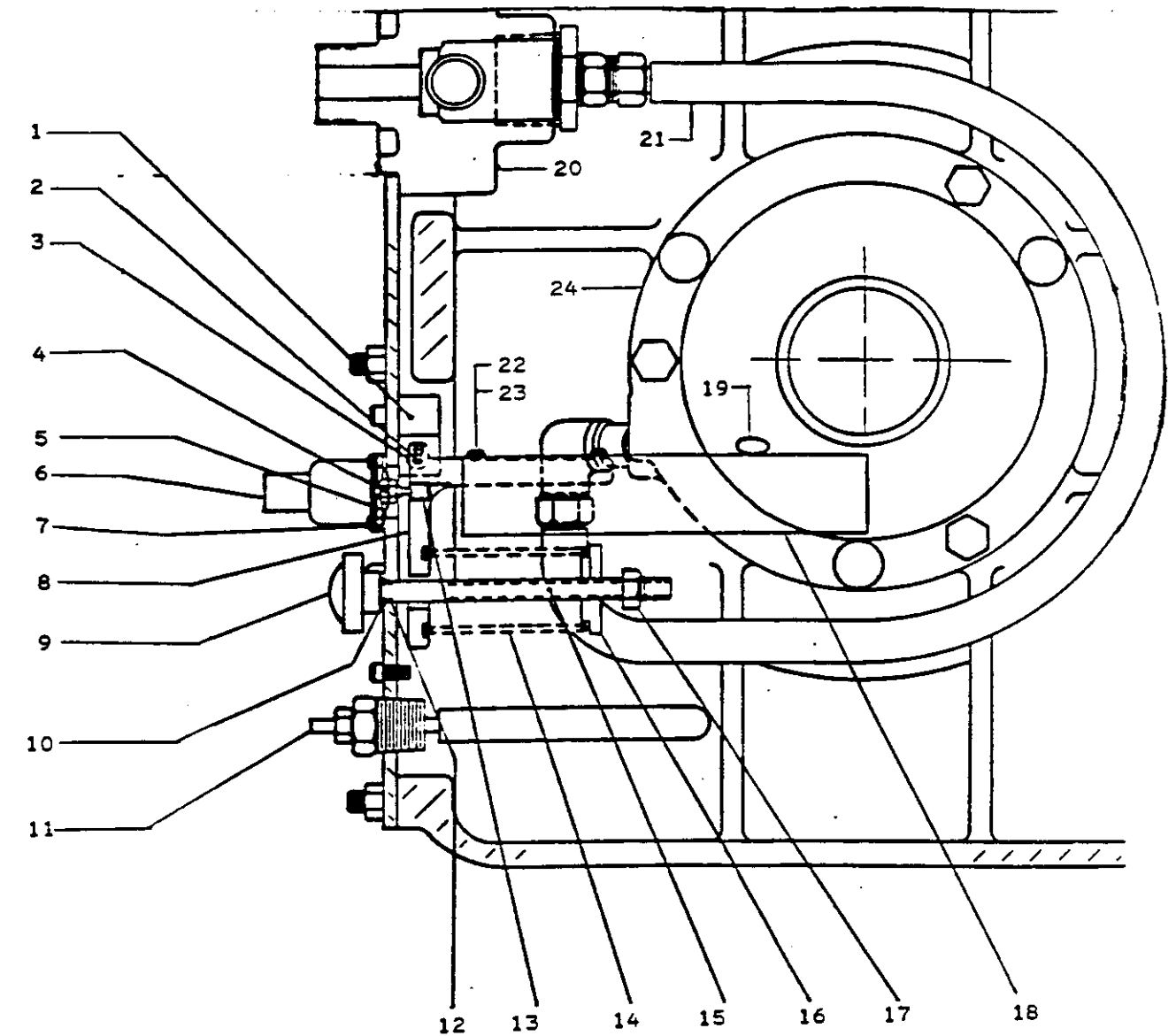

Figure 4. Cross Section of Control Plate with Hydraulic Control Parts

- | | |
|----------------------------------|----------------------------------|
| 1. Pivot Block | 13. Set Screw 5/16 - 24UNF |
| 2. Pivot Block Bearings | 14. Spring |
| 3. Pivot Block Dowel Pin | 15. Adjusting Stem |
| 4. Jam Nut $\frac{1}{2}$ - 28UNF | 16. Spring Retainer |
| 5. Diaphragm | 17. Jam Nut |
| 6. Hydraulic Pressure Control | 18. Oil Splitter |
| 7. Round Hd. Screw #8-32UNC | 19. Oil Exit Orifice |
| 8. Splitter Arm | 20. Oil Filter Adapter |
| 9. Pressure Adjustment Knob | 21. $\frac{1}{2}$ inch I.D. Hose |
| 10. Snap Ring | 22. Lockwasher |
| 11. Water Regulator Probe | 23. Round Hd. Screw |
| 12. "O" Ring | 24. Bearing Cap |

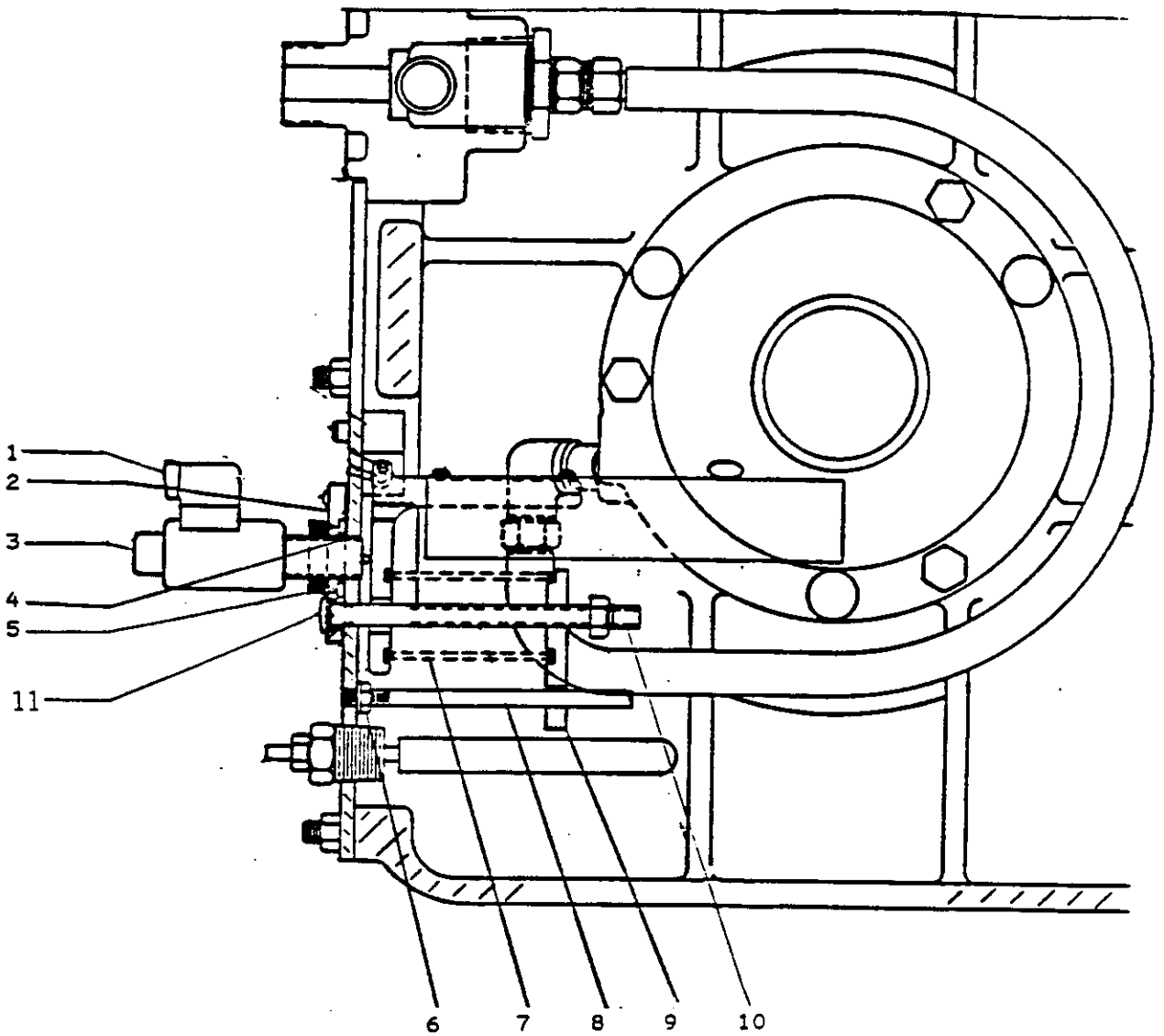

Figure 5. Cross Section of Control Plate
With Electric Control Parts.

- 1. Terminal Connector
- 2. Clamping Plate
- 3. Solenoid
- 4. Thread Seal Washer
- 5. Jam Nut

- 6. Hex Hd. Nut
- 7. Spring
- 8. Guide Rod
- 9. Spring Retainer
- 10. Adjusting Stem
- 11. Adjusting Stem Cover

OPERATION

Before Starting Hydroconstant, Check The Following:

- A. Check to see that all shaft couplings are secure and tight.
- B. Tightness of piping connections.
- C. Turn pump shaft by hand to make sure parts do not bind.
- D. Oil level is at least 1/2 inch (12 mm) above low indication line on sight glass gauge on side of housing.
- E. Close pump discharge valve. Reopen small amount.

CAUTION: Pump discharge valves must be opened part way prior to pump start-up to minimize any possible water hammering effect due to sudden pressure build up in discharge lines.

- F. Turn on power supply.

Start as follows:

1. Momentarily energize motor and observe either the rotating motor shaft or pump drive (Hydroconstant output) shaft for proper rotation. If in wrong direction, and motor is 3 phase type, disconnect main power supply, and interchange any two of the 3 power supply leads to the motor (at the electrical panel). If the motor is single phase, contact motor manufacturer for instructions on changing the rotation.

CAUTION: All Peerless vertical pumps are designed to rotate in a C.C.W. direction. Observe rotation by looking in a downward vertical direction at rotating pump or motor shaft. Prolonged reverse full speed rotation in excess of one minute may damage mechanical components inside Hydroconstant or pump.

2. Turn on water supply to the heat exchanger.
3. Place Hand-Off-Automatic switch on Automatic when supplied on control panel.

AFTER STARTING:

Using Hydraulic Control; Proceed as Follows:

1. Carefully bleed air from pressure sensing line.
2. Observe pressure gauge. Discharge pressure should become steady after a few minutes. Locate and adjust pressure control knob (3, Fig.3).

DISCHARGE PRESSURE ADJUSTMENT: Turn pressure control knob on plate clockwise to increase system pressure, counterclockwise to decrease. Change the adjustment in small amounts and wait several seconds to observe effect on pressure before another trial.

3. After discharge pressure becomes steady, slowly open or close pump discharge valve to get desired rate of water flow. Unit should operate automatically to maintain system pressure.

Using Pneumatic Control;

Adjust air pressure to pressure control (6, Fig. 4) to obtain desired discharge pressure in water lines.

Note: Changing or adjusting setting on adjusting stem (15, Fig. 4) will change spring tension (14, Fig. 4). This will change the relationship between air pressure signals and output (pump drive) shaft speed. Do not make adjustments on adjusting stem unless it is absolutely necessary.

Using Electric Control;

1. Place system controller (in control panel) on manual position. Adjust manual potentiometer in system controller. Observe the change in discharge pressure as the control voltage is changed.
2. Place system controller on automatic. Change automatic pressure setting at thumbwheel located outside of system controller (interface). Observe and take note of any difference between pressure gauges and automatic pressure reading on drive interface. Observe and take note of any pressure fluctuations. Recalibrate system controller according to instructions if necessary.

Note: Do not change setting of adjusting stem (10, Fig. 5). This will change spring tension and may cause the Hydroconstant to become uncontrollable. Do not attempt adjustments on the adjusting stem unless it is absolutely necessary.

Carefully inspect all units for water and oil leaks.

WATER LEAKS, Proceed as follows:

1. Tighten fittings adjacent to heat exchanger and pressure control.
2. If leaks persist, shut off motor, remove fittings and coat pipe threads with sealant. Replace and tighten fittings.
3. Refer to and read instructions in furnished pump bulletin to properly adjust water leakage out of packing gland on discharge head.

OIL LEAKS, Proceed as follows:

1. Tighten hex nuts on control and/or access plates.

Note: Oil leaks through stud openings in control and access plates may be stopped by removing hex nut and replacing underlying lock washer with a special sealing washer that has an inlaid O-ring.

2. If leaks persist, shut unit down and remove access plate (12, Fig. 3).

3. If there are leaks through control plate gasket, proceed to next step. If not, then coat access plate all around gasket contact area with a light coating of gasket sealant. Replace access plate and tighten hex nuts.

CAUTION: Do not coat both sides of gasket with gasket sealant. Apply only a light coating to gasket contact areas on control plate and/or on access plate. Too much gasket sealant can cause oil contamination problems.

4. Drain oil by removing pipe plugs (2, Fig. 3).

CAUTION: Oil drained from Hydroconstants and intended for reuse must be stored in a clean container. Oil contamination can have a very adverse effect on the usable operating life of bearings and oil seals.

5. Disconnect swivel fitting on oil pump outlet (1, Fig. 6). Disconnect swivel fittings on oil feed line (4, Fig. 6) if present.

6. Loosen and remove hex nuts and lockwashers on control plate. Carefully pull out control plate. Hold level and disconnect heat exchanger outlet swivel (6, Fig. 6) and oil filter inlet swivel (3, Fig. 6).

CAUTION: Do not bend oil splitter (18, Fig. 4) when removing control plate. A misshapen oil splitter can seriously impair running operation of Hydro-constant.

7. Coat gasket contact area on control plate with a light coating of gasket sealant. Replace control plate, reconnecting swivels at locations 3 and 6, Fig. 6.
8. Replace and tighten all lockwashers, hex nuts on control plate.
9. Reconnect swivel fittings at locations 1 and 4, Fig. 6.
10. Replace access plate and tighten hex nuts.

Note: O-rings in bottom (output) shaft seal are oiled prior to factory assembly. Some oil drippage after start-up may be observed. Normally this is a very small amount and will cease within one hour after start-up. If there is reason to believe oil leakage is serious, shut the motor off and drain the oil out of the Hydroconstant. Contact factory Service Department.

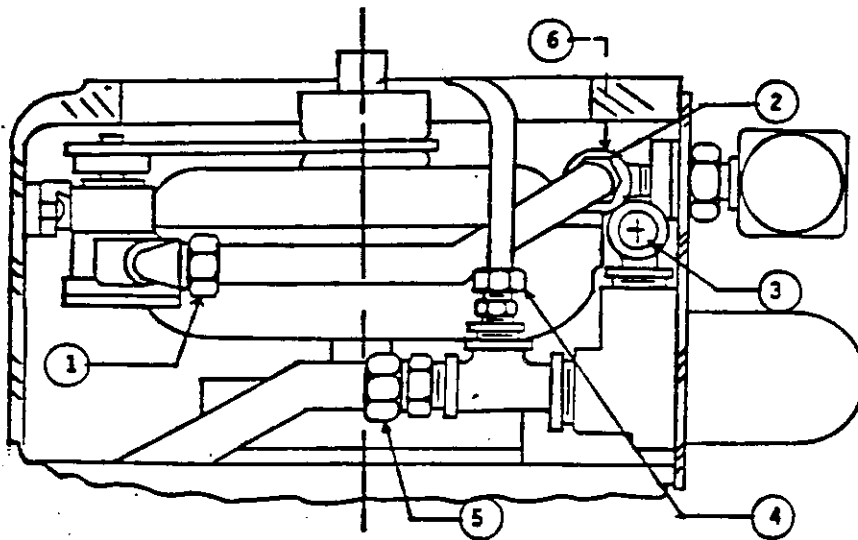

Figure 6: Inside View, Access Plate Removed, showing hose connections.

Hoses must be connected in the proper sequence before Hydroconstant can be operated:

- a. Oil pump outlet (1) must be connected to heat exchanger inlet (2).
- b. Heat exchanger outlet (6, hidden behind item #2) must be connected to oil filter inlet (3).
- c. Oil filter outlet (5) must be connected to bearing cap. (See item 21, Figure 4.)
- d. VS models will have a special oil feed line (4) to the top endbell bearing.
- e. Hydroconstants with special extra high thrust bearing stack and driven by 3500 or 2900 RPM motors will have a small flush line going to the bottom bearing cavity.

OPERATING TEMPERATURE, Adjust as follows:

1. Adjust pump discharge valve until pump shaft is rotating at 2/3 full rated motor speed. Special instruments such as a digital tachometer or strobe light will aid in this speed determination.
2. Adjust temperature control knob (8, Fig. 3) on valve on heat exchanger discharge to maintain an operating temperature of 140°F (60°C).

CAUTION: Maximum heat generation will occur when drive output shaft is rotating at 2/3 full rated motor speed. Prolonged operation with higher than recommended oil temperatures will adversely affect useful operating life of bearings and oil seals. Always make sure N/C connections of thermal cut out switch are wired in series with motor starting coil in control panel.

PERFORMANCE CHECK:

Proceed as follows if Hydroconstant fails to reach required speed or will not slow down when necessary or will not maintain proper running temperature.

1. Check and verify that the proper hydraulic, pneumatic or electric control signal at the proper strength is being sent to the control plate. If necessary, perform adjustments to bring control signal to proper strength.
2. Turn off the power supply to the motor and check the oil level. Oil level should be a minimum of 1/2 inch (12 mm) above low indicator line on sight glass gauge. See list at end of bulletin for proper oils.
3. Allow unit to cool to 90°F (32°C). Remove access plate (12, Fig. 3). Check hose connections (see figure 6). Check heat exchanger and oil filter connections.
4. Check to see that the two bleed orifices (13, Fig. 7) in coupling cover rim are not clogged. Using pins, carefully determine that the orifice diameters are as follows:

Fluid Coupling Size	Nominal Motor Speed RPM	Orifice Diameter	
		inches	mm
9A	1750 & 1450	0.125	3.175
11A	1750 & 1450	0.116	2.946
9A	3500 & 2900	0.091	2.311

CAUTION: Do not drop pins or any other objects inside fluid coupling or oil sump. Serious mechanical damage can occur if foreign objects are left inside drive.

5. Check the following:
 - a. Oil pump chain for proper tension (see Fig. 11).
 - b. Check and verify that oil pump and drive hub sprockets are level. Reset if necessary.
 - c. Make sure oil pump sprocket set screw is tight (15 to 20 in-lb of torque).

- d. Manually rotate fluid coupling assembly. Contact factory Service Department if fluid coupling cannot rotate.
6. Observe oil splitter (18, Fig. 4). Make sure oil splitter is not bent or snagged on bearing cap (24, Fig. 4). Splitter edge must be in line with edge of exit orifice in resting (0 volts or 0 pressure) position. (See figure 4).
7. If splitter appears bent or not proper location with respect to oil exit orifice, proceed as follows:
 - a. Drain oil and store in a clean container.
 - b. Refer to preceding section in bulletin pertaining to fixing oil seal leaks. Follow all steps pertaining to disconnection of swivel fittings. Carefully pull control plate out.
 - c. Straighten splitter if bent.
8. Hydraulic and Pneumatic Control Only. Proceed as follows:
 - a. Check position of splitter adjustment set screw (13, Fig. 4). The end of this screw provides a cone-shaped seat for the pointer on the pressure control (6, Fig. 4).
 - b. Reposition the pointer on the pressure control if it is not resting on the set screw cone.
 - c. The high and low speed limits may be restricted by the mechanical limits of the pressure control pointer movement. To increase maximum speed, rotate the set screw counter clockwise. To decrease minimum speed, rotate the set screw clockwise. Rotate one full turn in the desired direction, reattach the control plate to the drive, refill with oil, restart and check performance.
 - d. Contact factory Service Department if previous adjustments fail to change drive performance.
9. Electrical Control Only. Proceed as follows:
 - a. Apply and vary a 0 to 12 VDC signal to solenoid (3, Fig. 5). Check for splitter movement. If splitter moves, reattach the control plate to the drive, refill with oil, restart and check drive performance.

CAUTION: Disconnect or turn off controller at control panel before disconnecting leads to solenoid. An accidental shorting of electric leads can damage equipment and cause personal injury.
 - b. Loosen jam nut (5, Fig. 5) and carefully remove solenoid. Reapply voltage signal and check for pointer movement. Replace solenoid if there is no pointer movement.
 - c. Reattach solenoid to control plate. Reattach control plate to the drive, refill with clean oil and restart motor. Recalibrate solenoid.

Calibrate Electric Solenoid as follows:

WARNING Before making electrical connection to control panel, be certain that the power supply is turned off and that the disconnect switch is open. Disregard of this warning could result in fatal electrical shock.

1. Follow all applicable instructions pertaining to pump start up. Allow drive to warm up to normal operating temperatures. Hydroconstant must be running before solenoid can be calibrated.

CAUTION: Disconnect or turn off controller at control panel before disconnecting leads to solenoid. An accidental shorting of electric leads can damage equipment and cause personal injury.

2. Unplug terminal connection (1, Fig. 5). Loosen jam nut (5, Fig. 5). Turn solenoid out (CCW) until drive output shaft reaches maximum speed.
 3. Slowly turn solenoid in (CW) until drive output shaft starts to slow down (10 to 20 RPM drop).
- Note: Adjustments should be made slowly because drive response time can be several seconds.
4. When point of initial slowdown is found, record the speed and back solenoid out (CCW) exactly 1/2 turn.
 5. Lock solenoid in place by tightening jam nut (5, Fig. 5).
 6. Remove adjusting stem cover (11, Fig. 5). Turn adjusting stem CCW until it stops. Do not force adjusting stem beyond its stop.
 7. Connect terminal connector (1, Fig. 5) to controller. Turn on controller.
 8. Put controller in manual position (see instruction furnished with control panel).
 9. Adjust potentiometer to obtain a reading of 5 to 5-1/2 volts. (See voltmeter attached to controller.) Hydroconstant should slow down.
 10. Slowly turn adjusting stem (10, Fig. 5) CW until drive reaches maximum speed recorded in step 4. Readjust potentiometer as necessary to maintain 5 volts.
 11. Replace adjusting stem cover (11, Fig. 5). Check drive performance by varying solenoid control voltage. The Hydroconstant drive should reach minimum speed at 12 volts and maximum speed below 5 volts.
 12. Place controller in automatic position. (See controller instruction manual.)

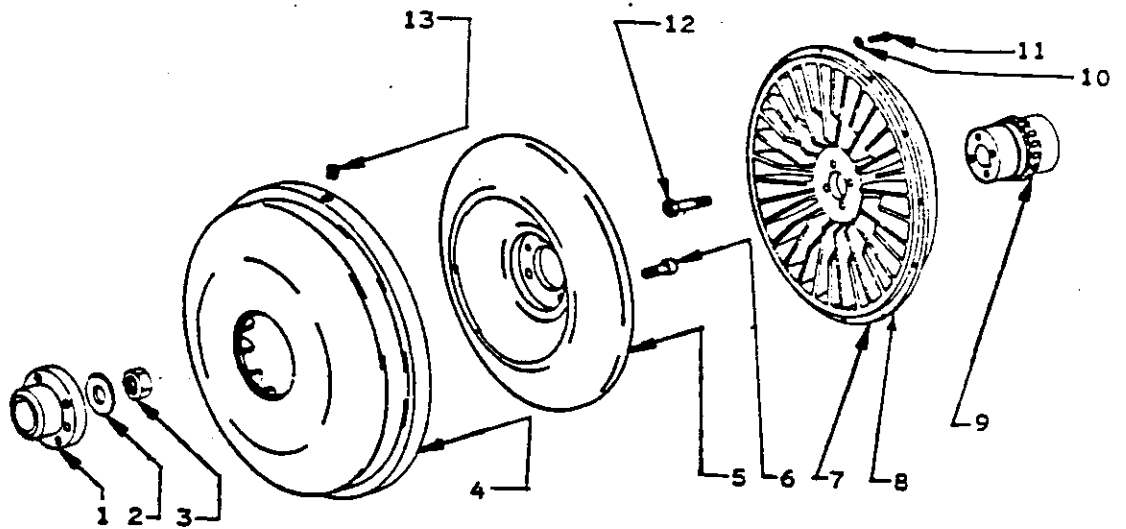

Figure 7. Fluid Coupling Assembly

- | | |
|--------------------------------|------------------------|
| 1. Output Hub | 8. Input Coupling Half |
| 2. Washer | 9. Drive Hub |
| 3. Jam Nut (3/4-16UNF) | 10. Washer |
| 4. Coupling Cover | 11. Socket Hd. Screw |
| 5. Output Coupling Half | 12. Hex Hd. Bolt |
| 6. Hex Hd. Bolt | 13. Bleed Orifice |
| 7. Coupling Gasket (Not Shown) | |

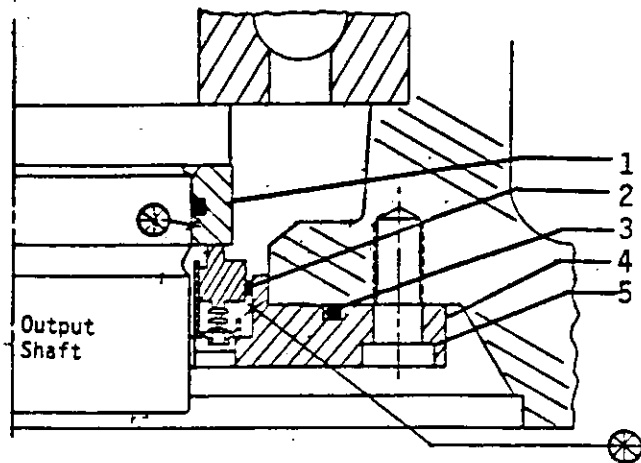

Figure 8. Output Shaft Seal Assembly

- | | |
|-----------------------|---------------------|
| 1. Seal Seat & O-Ring | 5. Socket Hd. Screw |
| 2. Oil Seal | |
| 3. O-Ring Gasket | |
| 4. Seal Retainer | |

⊗ Designated surfaces must not be damaged or nicked

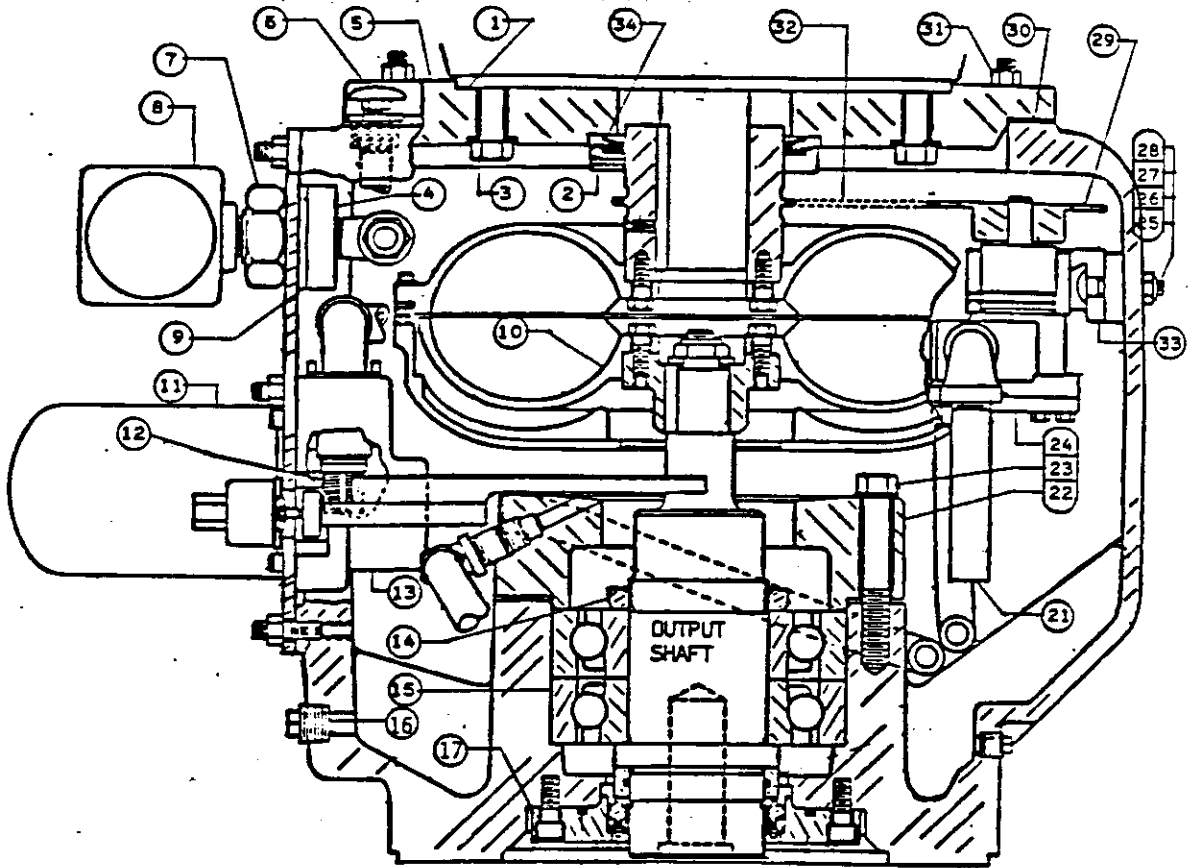

Figure 9. Basic Hydroconstant Cross Section

REF. NO. DESCRIPTION

REF. NO. DESCRIPTION

- | | | | |
|-----|----------------------|-----|----------------------------|
| ① | Motor Gasket | 17. | Output Shaft Seal Assembly |
| ② | V-Ring Retainer | 21. | Suction Hose |
| 3. | Hex Hd. Bolt | 22. | Bearing Cap |
| ④ | Cooler Adapter | 23. | Hex Hd. Bolt |
| ⑤ | Motor Adapter | 24. | Oil Pump |
| 6. | Air Breather | 25. | Carriage Bolt |
| 7. | Jam Nut | 26. | Seal Washer |
| 8. | Heat Exchanger | 27. | Countersunk Washer |
| 9. | Cooler Gasket | 28. | Hex Hd. Nut |
| 10. | Fluid Coupling Assy. | 29. | Oil Pump Sprocket |
| 11. | Oil Filter | 30. | Input Adapter Gasket |
| 12. | Bypass Valve | 31. | Hex Hd. Nut |
| 13. | Filter Adapter | 32. | Roller Chain |
| 14. | Bearing Locknut | 33. | Oil Pump Bracket |
| 15. | Thrust Bearings | ③④ | V-Ring Seal |
| 16. | Pipe Plug | | |

① Used with close coupled motors (VC models) only

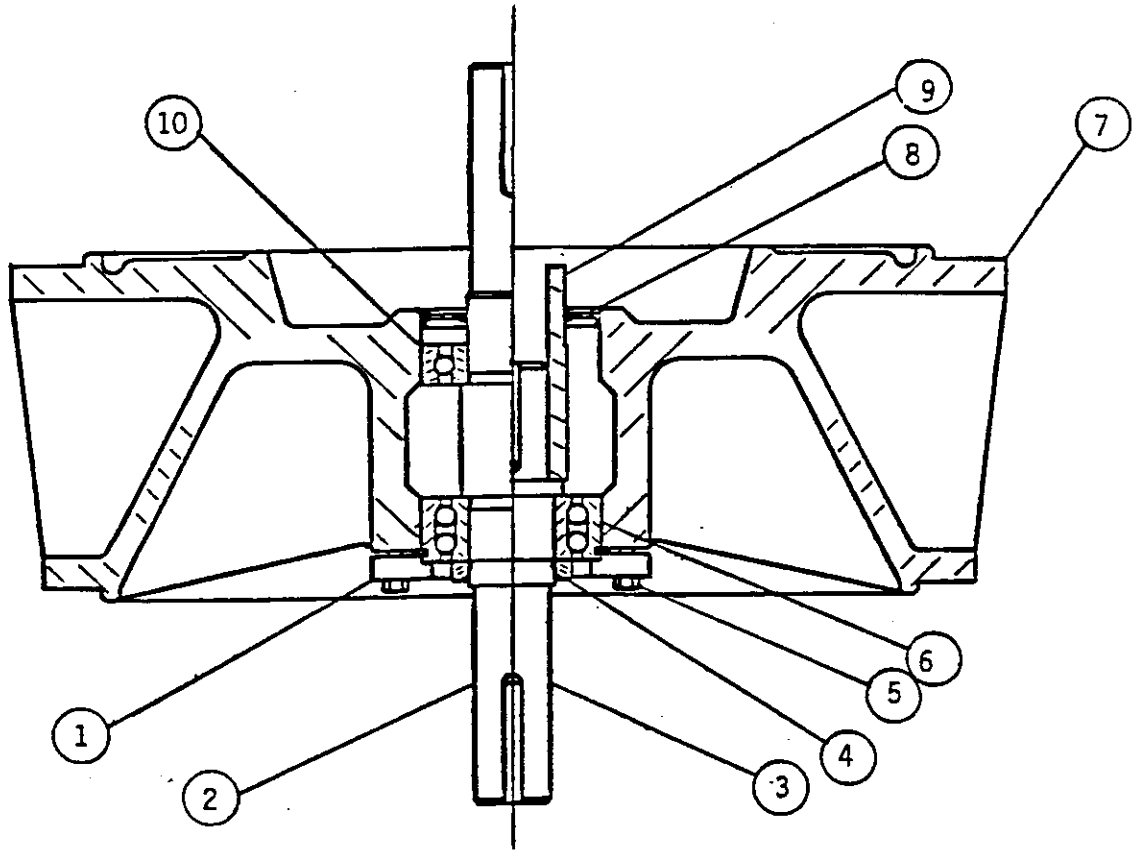

Figure 10. INPUT ENDBELL VS & VH MODELS

- | | |
|--------------------------|-----------------------------|
| 1. Bearing Cover | 6. Ball Bearing |
| 2. Input Shaft (VS only) | 7. Input Endbell |
| 3. Input Shaft (VH only) | 8. Oil Seal |
| 4. Bearing Locknut | 9. Shaft Coupling (VH only) |
| 5. Hex Head Bolt | 10. Ball Bearing (VS only) |

MAINTENANCE

PERIODIC INSPECTION: At regular intervals, inspect Hydroconstant as follows.

1. Check oil level. Oil level must be above low level mark on sight glass gauge while Hydroconstant is running.
2. Check for leaks at all pressure points; oil, around drain plugs, control plate, air breather and shaft seals; water, control pressure lines and heat exchanger.

WARNING

Before working on electrical equipment, insure that power to the electrical control panel is disconnected. Failure to do this may result in a fatal electrical shock.

3. Check electrical operation of controls on control panel.
4. Check inlet strainer in cooling water line for accumulation of sediment. Clean as necessary to avoid cooling water stoppage.

HEAT EXCHANGER:

The heat exchanger may require periodic cleaning. The water side may be cleaned with water softeners or by removing the cast iron headers at the ends and cleaning the water tubes with rods or brushes. The oil side can be cleaned using a methylene chloride compound.

LUBRICATION:

The internal parts are splash lubricated by the coupling oil. Follow motor manufacturer's instructions to lubricate motor bearings. Lubricate pump bearings, if used, as instructed in bulletin furnished with pump.

OIL CHANGE:

When run continuously, oil should be drained at least once a year (9,000 hours of operation). Disconnect (shut off) power to the motor. Wait until oil temperature is below 90°F (32°C), and remove a pipe plug on low end of housing. Remove all the rest of the pipe plugs and drain all sump cavities. Clean and replace pipe plugs. Fill with new clean oil to proper level on sight glass gauge. Approximate capacity is 14 quarts (13 liters).

OIL FILTER:

Replace oil filter every time oil is changed. Use only "Pall" model No. "HC9540SUPH4H" (Peerless part number "2689240-000").

CAUTION: Do not add or drain oil or loosen oil filter while Hydroconstant is running. Hot oil splashage can cause personal injury. Do not attempt repair or maintenance procedures or oil changes with oil temperature above 90°F (32°C). Painful and hazardous burns may result.

REPAIR:

Motor; motor repair should be made by a repair shop authorized by the specific motor manufacturer noted on motor nameplate. Pump; refer to and follow instructions in bulletin furnished with pump. Control panel; repair must be made by licensed electricians or factory service personnel. Hydroconstant; refer to appropriate disassembly and reassembly sections in this bulletin.

**INSTRUCTIONS FOR ADJUSTMENT OF
ROLLER CHAIN TENSION**

USE VERY LIGHT ("ONE POUND") FORCE TO DEPRESS CHAIN AT THE MIDSPAN WHILE MEASURING DEFLECTION. RE-POSITION THE OIL PUMP IF DEFLECTION IS NOT AS SHOWN.

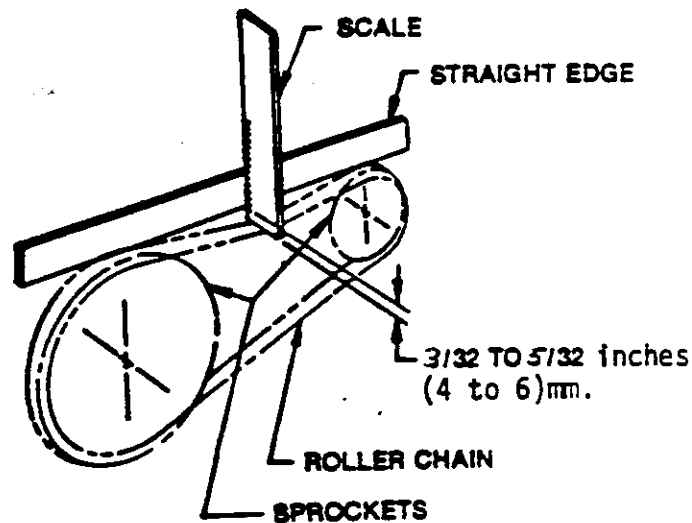

Figure 11. Chain Tension Adjustments

Acceptable Oils for Hydroconstant Use

Supplier	Product Name
Amoco	American Industrial 68
Atlantic Richfield	Duro AW S315
Chevron	GST 68
Shell Oil Co.	Tellus 68
Exxon	Terresstic 68
Standard Oil (Ohio)	Factovis 52
Sun Oil Co.	Sunvis 931
Texaco	Rando H.D. 68
Union Oil Co.	Unax RX 315

These oils all are non-detergent mineral oils with viscosity of 68 centistokes at 100°F (38°C). All these oils have additives which give them foam and oxidation resistant properties. Other oils which are not listed but meet the same specifications may be used.

Notice: Materials of construction, specifications, dimensions, design features, and application information, where shown in this bulletin, are subject to change and/or modification without notice by Peerless Pump at their option.



Peerless Pump Company

2005 Dr. Martin Luther King Jr. Street

Indianapolis, IN 46202

Phone: (317) 925-9661 • Fax: (317) 924-7388