

Variable Speed Fluid Drives Size 3C Vertical Hydroconstant[®] Drives Types VC, VS and VH

Instructions

- Installation
- Operation
- Maintenance

Read this entire book

before attempting to install, operate or repair this drive. Properly installed, your Peerless Pump variable speed drive will give you satisfactory, dependable service. We urge that you read carefully these step-by-step instructions, to simplify any problems of installation, operation or repair.

Failure to read and comply with installation and operating instructions will void the responsibility of

the manufacturer and may also result in bodily injury as well as property damage.

This book is intended to be a permanent part of your drive installation and should be preserved in a convenient location for ready reference. If these instructions should become soiled obtain a new copy from Peerless Pump. Include drive size, and/or serial number with your request.

WARRANTY

New equipment manufactured by Seller is warranted to be free from defects in material and workmanship under normal use and service for a period of one year from date of shipment; Seller's obligation under this warranty being limited to repairing or replacing at its option any part found to its satisfaction to be so defective provided that such part is, upon request, returned to Seller's factory from which it was shipped, transportation prepaid. This warranty does not cover parts damaged by decomposition from chemical action or wear caused by abrasive materials, nor does it cover damage resulting from misuse, accident, neglect, or from improper operation, maintenance, installation, modification or adjustment. This warranty does not cover parts repaired outside Seller's factory without prior written approval. Seller makes no warranty as to starting equipment, electrical apparatus or other material not of its manufacture, since the same are usually covered by warranties of the respective manufacturers thereof.

In the event, notwithstanding the terms of this agreement, it is determined by a court of competent jurisdiction that an express warranty has been given by Seller to Purchaser with respect to the head, capacity or other like performance characteristics of said equipment, Seller's liability for breach of the same shall be limited to accepting return of such equipment F.O.B. plant of manufacture, refunding any amount paid thereon by Purchaser (less depreciation at the rate of 15% per year if Purchaser has used equipment for more than thirty (30) days) and cancelling any balance still owing on the equipment.

THIS WARRANTY IS EXPRESSLY IN LIEU OF ANY OTHER WARRANTIES, EXPRESSED OR IMPLIED, AND SELLER SPECIFICALLY DISCLAIMS ANY IMPLIED WARRANTY OF MERCHANTABILITY OR FITNESS FOR A PARTICULAR PURPOSE.



Peerless Pump Company
2005 Dr. Martin Luther King Jr. Street
Indianapolis, IN 46202
Phone: (317) 925-9661 • Fax: (317) 924-7388

B-4850271

IMPORTANT SAFETY PRECAUTIONS

Pump parts, Hydroconstant drives, and the tools and rigging equipment used in installation are heavy and may easily cause personal injury if dropped or carelessly handled. The normal precautions and safety rules associated with the erection of heavy machinery, in regard to manual lifting, use of power equipment, and handling of tools, must be observed in the installation of this drive.

Petroleum-base cleaning solvents are flammable. Open flame or smoking by personnel in the vicinity of these solvents is extremely hazardous and must not be permitted.

Do not work under a heavy suspended object unless there is a positive support under it to stop its fall in

event of sling or hoist failure. Disregard of this warning could result in grave personal injury.

Before opening the conduit box of an electric motor, be certain that the current to the motor is shut off. An electrical shock from contact with live motor leads can be fatal.

Before attempting repairs to drive or pump open the disconnect switch to electric motor. This prevents accidental running of pump motor. Starting motor during pump repair activities could damage pump and may cause personal injury.

INTRODUCTION

WARNING

The drives described in this bulletin must not be installed in any manner except as specified herein, and must not be operated at speeds, horsepower loads, or temperatures other than those specified when the drive was assembled by the factory. Failure to limit operation of the drives to the conditions specified could damage the drives and may cause malfunction or damage of interconnected equipment. Violation of this warning will void the warranty and may result in serious property damage or grave personal injury.

ALLOWABLE LOADS

| Hydraulic (Fluid) Coupling Size | Motor Speed (RPM) | Motor Size - Max. | |
|------------------------------------|----------------------|-------------------|-----|
| | | HP | KW |
| 14 | 1750 | 125 | 90 |
| 17 | 1750 | 250 | 175 |
| 14 | 1450 | 60 | 40 |
| 17 | 1450 | 200 | 150 |

UPON RECEIPT OF HYDROCONSTANT DRIVE: Check carefully to see that all of the equipment has been received. Report immediately any shortages or damages to the transportation company handling the shipment, noting the extent of the damage or shortage on the freight bill and bill of lading.

Do not leave the unit exposed to weather or construction hazards. The drive may become mechanically damaged. This drive is a well designed and carefully manufactured unit. It should be given the same attention accorded to any precision machine.

The satisfactory operation of a pump and drive depends to a large extent upon proper installation. These instructions cannot answer every question that may arise as each installation will be different. The installer and the operator of this equipment must use good judgement to adapt these procedures to the installation.

DESCRIPTION: The Hydroconstant drive consists of a fluid coupling which is designed to allow continuous, smooth variance of output shaft speed in direct response to a fluid pressure signal as may be generated by a centrifugal pump connected to the coupling. The coupling input shaft rotates at the relatively constant speed of an electric motor. The basic operating sequence is described as follows: Fluid pressure acts through the control mechanism to regulate the coupling output speed. The control mechanism varies the amount of oil, supplied by a gear pump, admitted to the coupling. As the oil continuously flows from the coupling through fixed orifices, admission of more oil increases output shaft speed, less oil reduces output shaft speed. Stabilizing the pressure signal to the control mechanism will fix the output shaft speed at a preselected ratio (always less than one) of the input speed.

WARNING

Hydroconstant drives and pumps weigh several hundred pounds. Do not work under a heavy, suspended object unless there is a positive support under it to stop its fall in the event of sling or hoist failure. Disregard of this warning could result in grave personal injury.

A SUGGESTED METHOD OF LIFTING VERTICAL HYDROCONSTANT DRIVES

Remove motors from VH and VS models before lifting to reduce weight and to increase stability of the suspended drive. Weights to be lifted can be found on the job outline drawing, or may be obtained from Peerless Pump Indianapolis factory.

Use only 1/2-13 UNC thread, drop forged eyebolts conforming to specifications and requirements of ANSI B18.15, installed in opposite corners of the drive housing. Make sure that the eyebolts are threaded into the housing a minimum length of .69 inches (17.5 mm).

Lifting lines attached to the eyebolts must share the total load equally, with lift action passing thru the center axis of the threaded eyebolt shank (0° lifting angle). The use of a properly designed spreader bar is suggested as a means to accomplish this lifting requirement.

Steady lines must be connected to the motor when lifting VC models. Provide for equalized tension on steady lines. **NEVER** lift the combined weight of a motor and drive by the motor lines alone. Smaller motor frames are incapable of supporting this combined weight. **ALWAYS** provide steady lines to the motors. Heavy motor frames can pivot the system in mid-air. **NEVER** try to lift a drive with the pump discharge head, column, or any other driven equipment attached to the drive housing.

A slow lift is always recommended with a maximum acceleration limit of 1.5 G. Similar methods of rigging or lifting may be employed by skilled and qualified riggers to reduce, or equal, similar lifting stress limits. **NEVER** reach or stand under the Hydroconstant drive, or the motor, or the combination while lifting is in progress.

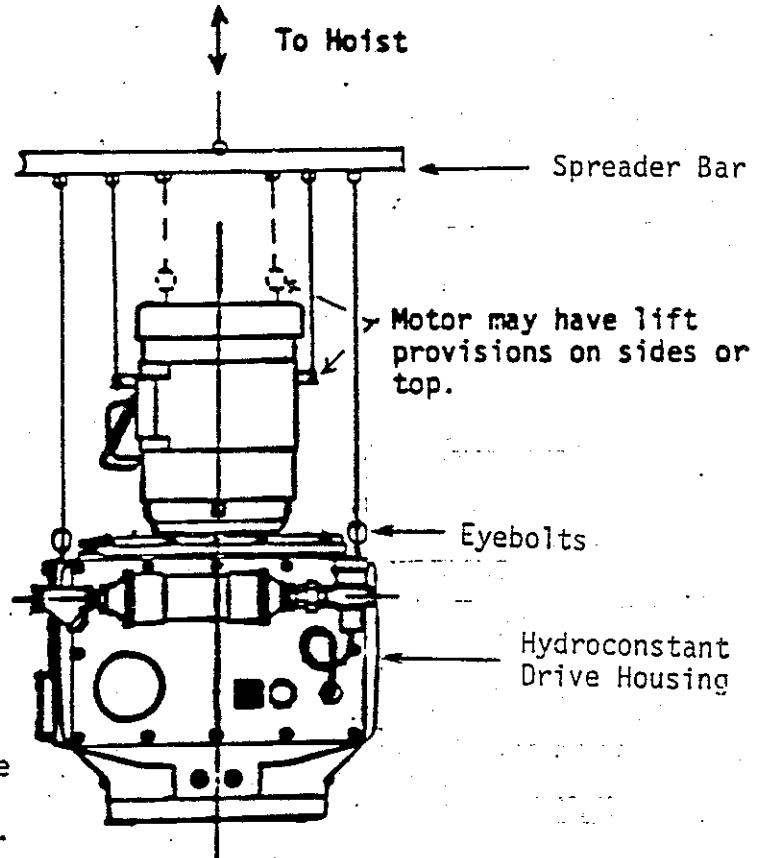

INSTALLATION

WARNING

Do not work under a heavy, suspended object unless there is a positive support under it to stop its fall in event of sling or hoist failure. Disregard of this warning could result in grave, personal injury.

LOCATION: The Hydroconstant unit should be installed in a clean, well-drained and ventilated area, and be accessible for inspection and proper care. Ample room should be provided for installation and removal. Be sure the space is vented to the outside atmosphere to avoid a rise of ambient temperature and collection of any oil vapor. Refer to bulletin furnished with pump for instructions for base mounted units installation.

These cover the following:

- (A) Foundation
- (B) Mounting
- (C) Alignment
- (D) Grouting
- (E) Piping

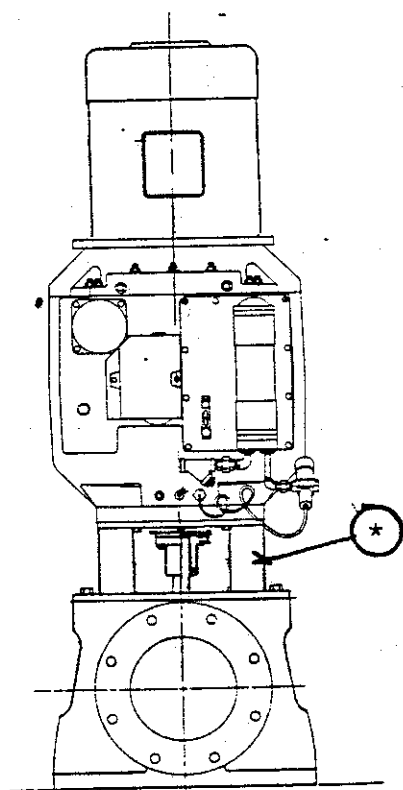

Figure 1. Model VC Hydroconstant with close coupled motor and vertical turbine pump.

WARNING

Before making electrical connection to control panel, be certain that the power supply is turned off and that the disconnect switch is open. Disregard of this warning could result in fatal electrical shock.

ELECTRICAL CONNECTIONS: Select a convenient location and hang or footmount the electrical panel. Connect power supply to the panel, and make interconnections between panel and motor in accordance with the schematic wiring diagrams supplied with the unit. All work must conform with national and local codes. Line voltage and wire capacity must match the ratings stamped on the electrical panel nameplate.

NOTE

Only items listed in job order are furnished by Peerless Pump.

WARNING

Use only qualified personnel or trained riggers to move or lift vertical Hydroconstants.

NEVER lift vertical Hydroconstants using hooks or slings on shafts.

NEVER place eyebolts in tapped holes except for removal of a part to perform service work.

NEVER lift pump assemblies with vertical Hydroconstants attached.

NEVER pick up a vertical Hydroconstant or pump assembly by an attached yoke/ adapter.

ALWAYS follow approved lifting instructions and safety precautions.

DISREGARD of these warnings can result in equipment damage, serious personal injury, or death

CAUTION

Foundation must be firm, level and strong enough to support entire weight of vertical Hydroconstant and pump assembly without deflection. The foundation must be in full contact with machined bottom of discharge head.

WARNING

Hydroconstant yoke/adapters are designed for compression support of drives and motors. Do not lift drives and pump assembly by attached yoke/adapters. Failure to follow approved lifting methods and safety precautions can result in equipment damage, serious personal injury or death.

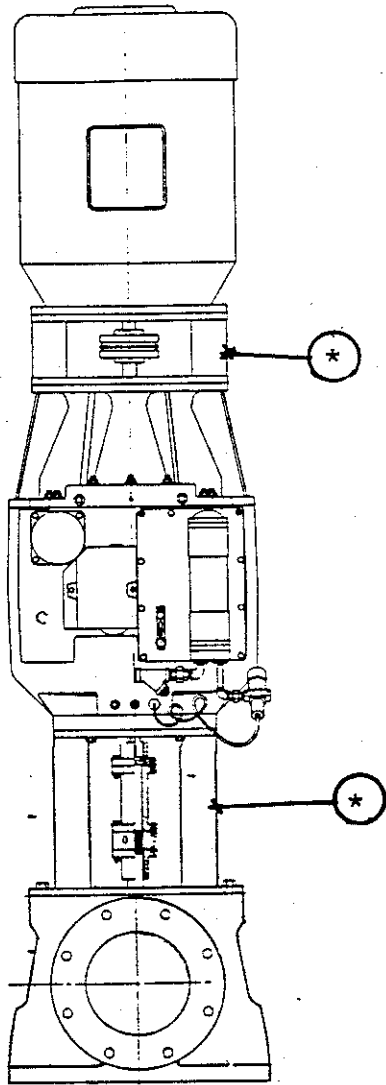

Figure 1(a)

Model VS, Vertical
Solid Shaft Motor

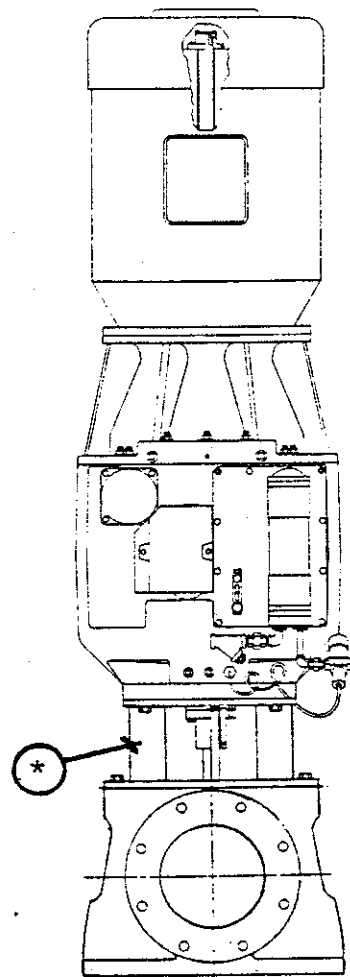

Figure 1(b)

Model VH, Vertical
hollow shaft motor

Figures 1(a & b) both show vertical Hydroconstants with external coupled motors. Figure 1(a) shows a spacer output shaft coupling arrangement. Figure 1(b) shows a socket type shaft coupling arrangement. See Figures 1(d) and 1(e) for output shaft coupling details.

Warning Coupling guards must be installed in designated locations (*) before start-up. Guards must be in place at all times when motor is running. Disregard of this warning may result in serious personal injury or death.

Caution Use SAE GR. 8 (high strength steel) bolts with shaft coupling assembly. Do not indiscriminately substitute different grades of bolts.

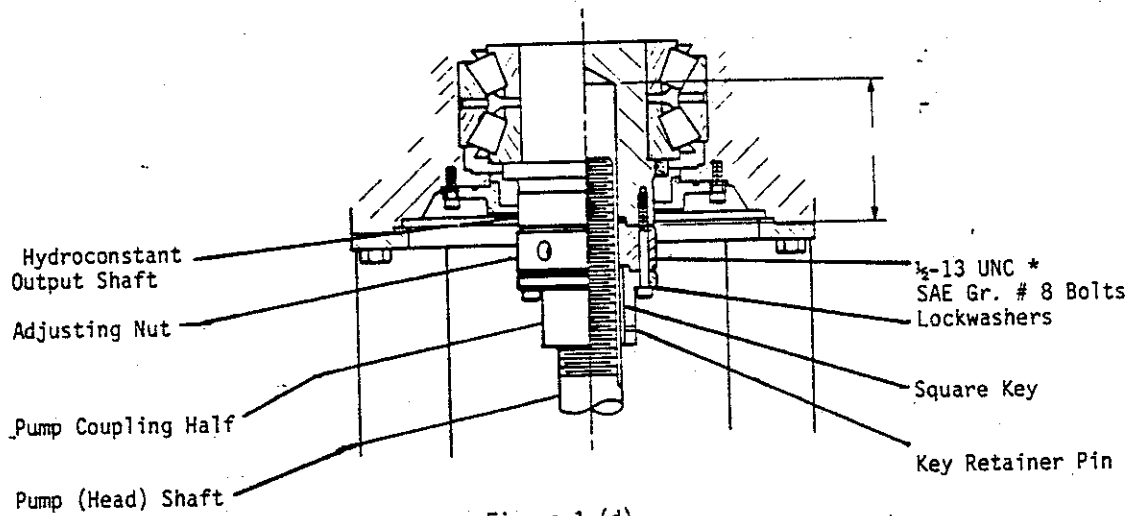

Figure 1 (d)
Socket Type Output Shaft Coupling

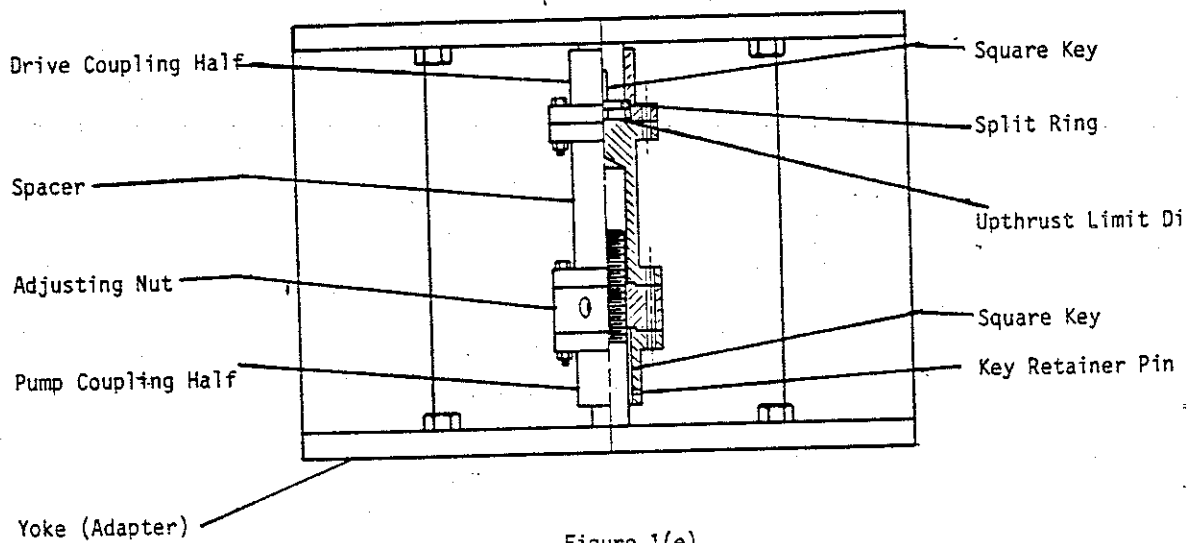

Figure 1(e)
Spacer Type Output Shaft Coupling

Pump Shaft Lateral:

Top column shaft on all Peerless vertical turbine pumps must be raised 1/16 to 1/8 inch (1.5 to 3 mm) from resting position. Refer to and read section in pump instruction manual pertaining to the proper setting of shaft lateral.

- A. Turn adjusting nut - Fig. 1(d) or 1(e) until gap between it and output shaft (or spacer) is equal to specified lateral setting.
- B. Replace shaft coupling bolts. Raise column shaft by tightening shaft coupling bolts. Tighten shaft coupling bolts to within: 72 to 75 Ft-Lbs for $\frac{1}{2}$ -13 UNC bolts.
- C. Check for free rotation of pump shaft without drag. Deeper setting pumps may have to be adjusted again with wider gap to allow for normal lateral and shaft settling.
- D. Insufficient or excessive lateral adjustments will cause the top column shaft to bind. Recheck and reset lateral.

Heat Exchanger Water Supply:

- A. Clean cooling water at 20 psig minimum pressure (70 k.pa.), 125 psig maximum pressure (860 k.pa.) must be provided to heat exchanger.
- B. Use pipe size adequate to support a minimum flow rate of 1 USGPM (.3 m³/hr.) for each 10 HP (7.5 kw) increment of drive motor used.
- C. Closed loop heat exchanger systems (cooling water returned to suction pipe, well or other main source) cannot be used for human or animal consumption, or in any application where oil contamination of pumped liquids can create problems, or where prohibited by local codes. If this method is employed, a check valve must be used between the water modulating valve (7, Fig. 3) and the return location. A thermal safety valve set for 85°F (30°C) must be installed on the discharge head.

Outdoor Installations:

- A. If the drive is exposed to freezing temperatures during periods of inactivity, water may freeze and burst heat exchangers, connecting lines, hydraulic pressure controls (12, Fig. 3) and sensing lines. Consult with factory on protection or provide for drive shutdown and complete drainage of all water.
- B. Normally supplied air breather (, Fig. ?) is not designed to filter dust. If drive is exposed to dust laden atmosphere, oil contamination can occur which will destroy bearings and oil seals. Consult with factory on protection.

Prevention of Pump Backspin:

If pump backspin can occur, an automatic start system panel must be provided with a timed, restart lockout. Mechanical anti-reverse ratchets are not available on drive. Do not rely on check valves in pump discharge lines for prevention of backspin.

SPEED CONTROL CONNECTIONS:

A. Hydraulic Control;

Connect a 1/2 inch (12 mm) I. D. pressure sensing line between pump discharge (manifold on downstream side of check valve) and the pressure control (1, Fig. 4). Make or furnish provisions for bleeding entrapped air from pressure sensing lines. Connect only to straight sections of discharge pipe away from fittings and flanges.

B. Pneumatic Control;

Connect a 1/4 inch (6 mm) I. D. air line to pressure control (1, Fig. 4). Pump drive shaft will reach maximum speed at low air pressure and minimum speed at high air pressure.

C. Electric Control;

Read instructions furnished with system controller (control panel). Solenoid (1, Fig. 5) must be connected to system controller according to furnished wiring diagram. Voltage control range is from 0 to 12 V.D.C. Pump drive shaft will reach maximum speed at low end of voltage control range and minimum speed at high end of voltage control range.

Thermal Cutout Switch:

The thermal cutout switch is a high temperature protective device. Its use is highly recommended because prolonged operating temperatures in excess of 155°F (68°C) will decrease effective operating life of bearings and oil seals.

- A. The white and yellow lead wires form a normally closed connection. Connect in series with motor starter coil in control panel.
- B. The white and brown lead wires form a normally open connection. Connect to an alarm or indicator light.
- C. Enclose all three lead wires in water proof or explosion proof conduit.
- D. The thermal cutout switch is present to trip (change electrical connections) when operating temperature exceeds 155°F (68°C). The thermal cutout switch will reset automatically when oil temperature drops to about 140°F (60°C)

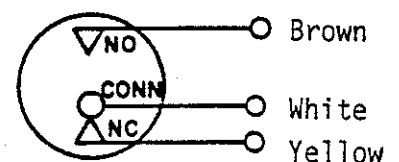
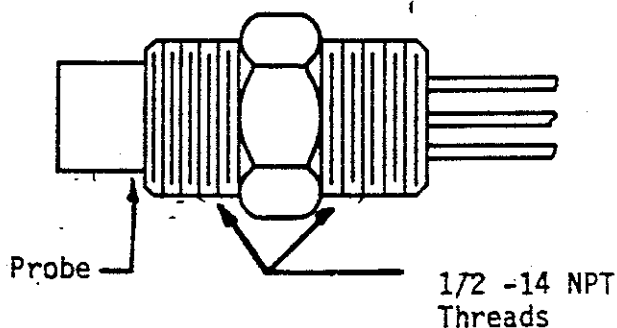

Figure 2(a) Wiring Diagram

Figure 2. Thermal Cutout Switch

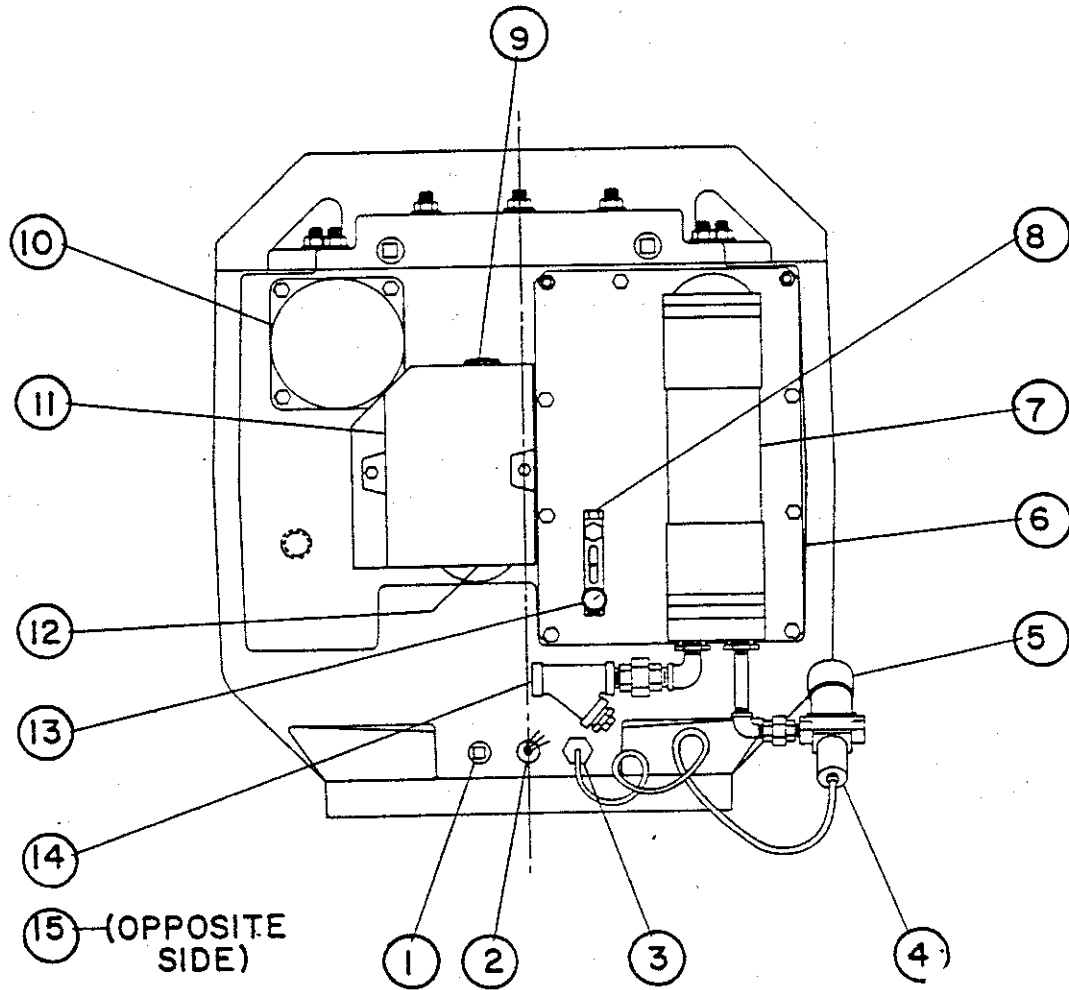

Figure 3. Front View of Hydroconstant

- | | |
|--------------------------------|--|
| 1. Pipe Plug 1/2-14 NPT | 8. Oil Level Gage |
| 2. Thermal Cutout Switch | 9. Pressure Adjustment Knob |
| 3. Water Modulating Probe | 10. Oil Filter |
| ** 4. Water Modulating Valve | 11. Control Cover |
| 5. Temperature Adjustment Knob | 12. Control Connection (see Figures 4 & 5) |
| 6. Heat Exchanger Mount Plate | 13. Thermometer |
| 7. Heat Exchanger | * 14. Water Strainer |
| | 15. Access Plate |

*Heat exchanger inlet, 1/2-14 NPT on 50 to 100 HP systems, 1-11 NPT on 125 to 250 HP systems.

**Heat exchanger outlet, 3/8-18 NPT on 50 to 100 HP systems, 1/2-14 NPT on 125 to 150 HP systems, and 3/4-14 NPT on 200 to 250 systems.

CAUTION If cooling water supply is taken from pump discharge and hydraulic control is used, make sure pressure sensing line and heat exchanger water supply are taken from separate locations. This will help avoid control problems.

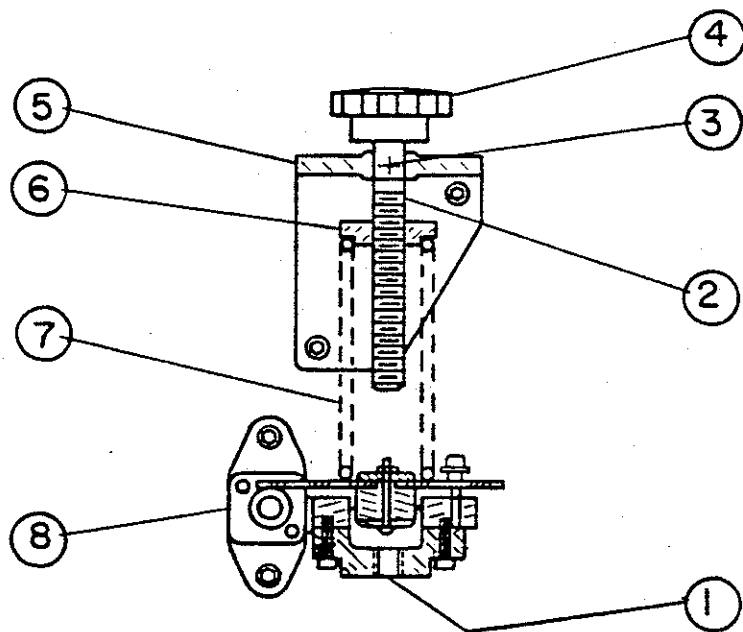

Figure 4. Hydraulic and Pneumatic Speed Control Assembly.
Remove control cover (11, Fig. 3) to view.

1. Pressure connection (1/4-18 NPT)
2. Spring adjustment screw
3. Setscrew
4. Spring (pressure) adjustment knob
5. Adjusting screw bracket
6. Spring retainer
7. Control spring
8. Pressure control assembly (See Fig. 6 for details.)

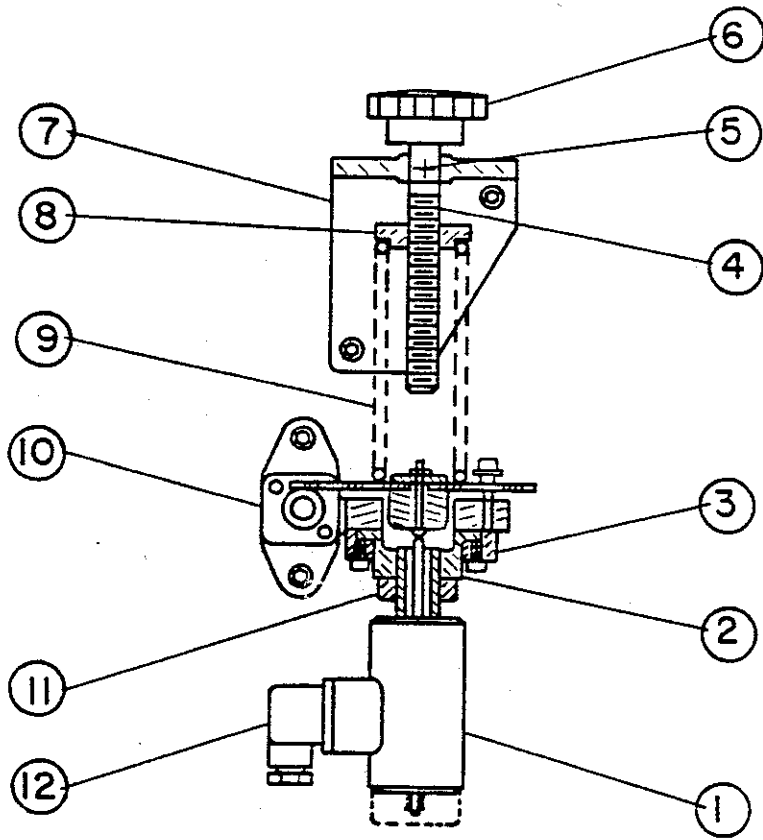

Figure 5. Electric Speed Control Assembly.
Remove control cover (11, Fig. 3) to view.

- | | |
|----------------------------|-------------------------------|
| 1. Proportional solenoid | 7. Adjusting screw bracket |
| 2. Slip ring | 8. Spring retainer |
| 3. Slip ring clamp | 9. Control spring |
| 4. Spring adjustment screw | 10. Pressure control assembly |
| 5. Setscrew | 11. Locknut |
| 6. Spring adjustment knob | 12. Conduit connector |

OPERATION

Before Starting Hydroconstant, Check The Following:

- A. Check to see that all shaft couplings are secure and tight.
- B. Tightness of piping connections.
- C. Turn pump shaft by hand to make sure parts do not bind.
- D. Oil level is at least 1/2 inch (12 mm) above low indication line on sight glass gauge on side of housing.
- E. Close pump discharge valve. Reopen small amount.

CAUTION Pump discharge valves must be opened part way prior to pump start-up to minimize any possible water hammering effect due to sudden pressure build up in discharge lines.

- F. Turn on power supply.

Start as follows:

1. Momentarily energize motor and observe either the rotating motor shaft or pump drive (Hydroconstant output) shaft for proper rotation. If in wrong direction, and motor is 3 phase type, disconnect main power supply, and interchange any two of the 3 power supply leads to the motor (at the electrical panel). If the motor is single phase, contact motor manufacturer for instructions on changing the rotation.

CAUTION All Peerless vertical pumps are designed to rotate in a C.C.W. direction. Observe rotation by looking in a downward vertical direction at rotating pump or motor shaft. Prolonged reverse full speed rotation in excess of one minute may damage mechanical components inside Hydroconstant or pump.

2. Turn on water supply to the heat exchanger.
3. Place Hand-Off-Automatic switch on Automatic when supplied on control panel.

AFTER STARTING:

Using Hydraulic Control; Proceed as Follows:

1. Carefully bleed air from pressure sensing line.
2. Observe pressure gauge. Discharge pressure should become steady after a few minutes. Locate and adjust pressure control knob (9, Fig.3).

DISCHARGE PRESSURE ADJUSTMENT: Turn pressure control knob on plate clockwise to increase system pressure, counterclockwise to decrease. Change adjustment in small amounts and wait several seconds to observe effect on pressure before another trial.

3. After discharge pressure becomes steady, slowly open or close pump discharge valve to get desired rate of water flow. Unit should operate automatically to maintain system pressure.

Using Pneumatic Control;

Adjust air pressure to pressure control (1, Fig. 4) to obtain desired discharge pressure in water lines.

Note: Changing or adjusting setting on adjusting stem (2, Fig. 4) will change spring tension (.7, Fig. 4). This will change the relationship between air pressure signals and output (pump drive) shaft speed. Do not make adjustments on adjusting stem unless it is absolutely necessary.

Using Electric Control;

1. Place system controller (in control panel) on manual position. Adjust manual potentiometer in system controller. Observe the change in discharge pressure as the control voltage is changed.
2. Place system controller on automatic. Change automatic pressure setting at thumbwheel located outside of system controller (interface). Observe and take note of any difference between pressure gauges and automatic pressure reading on drive interface. Observe and take note of any pressure fluctuations. Recalibrate system controller according to instructions if necessary.

Note: Do not change setting of adjusting stem (4, Fig. 5). This will change spring tension and may cause the Hydroconstant to become uncontrollable. Do not attempt adjustments on the adjusting stem unless it is absolutely necessary.

Carefully inspect all units for water and oil leaks.

WATER LEAKS, Proceed as follows:

1. Tighten fittings adjacent to heat exchanger and pressure control.
2. If leaks persist, shut off motor, remove fittings and coat pipe threads with sealant. Replace and tighten fittings.
3. Refer to and read instructions in furnished pump bulletin to properly adjust water leakage out of packing gland on discharge head.

OIL LEAKS, Proceed as follows:

1. Tighten hex nuts on mount and/or access plates (6 & 15, Fig. 3).

Note: Oil leaks through stud openings in mount and access plates may be stopped by removing hex nut and replacing underlying lock washer with a special sealing washer that has an inlaid O-ring.

If oil leaks persist, proceed as follows:

1. Shut unit down and allow to cool to 90°F (32°C).
2. Access plate: Remove and apply a light coating of gasket sealant to gasket contact area on access plate. Replace access plate and tighten hex nuts.

CAUTION Do not coat both sides of gasket with gasket sealant. Apply only a light coating to gasket contact areas on removable plates. Too much gasket sealant can cause oil contamination problems.

3. Heat exchanger mount plate: Remove pipe plug (1, Fig. 3). Drain oil and store in a clean container. Remove mount plate and apply a light coating of gasket sealant to gasket contact area on mount plate. Replace mount plate and tighten hex nuts.
4. Replace pipe plug (1, Fig. 3). Remove air breather. Refill Hydroconstant through air breather opening. Remove small pipe plug on top of housing to vent air during refill.

Note: O-rings in bottom (output) shaft seal are oiled prior to factory assembly. Some oil drippage after start-up may be observed. Normally, this is a very small amount and will cease within one hour after start-up. If there is reason to believe oil leakage is serious, shut the motor off and drain the oil out of the Hydroconstant. Contact Factory Service Department.

CAUTION Oil drained from Hydroconstants and intended for reuse must be stored in a clean container. Oil contamination can have a very adverse effect on the usable operating life of bearings and oil seals.

OPERATING TEMPERATURE, Adjust as follows:

1. Adjust pump discharge valve until pump shaft is rotating at 2/3 full rated motor speed. Special instruments such as a digital tachometer or strobe light will aid in this speed determination.
2. Adjust temperature control knob (5, Fig. 3) on valve on heat exchanger discharge to maintain an operating temperature of 140°F (60°C).

CAUTION Maximum heat generation will occur when drive output shaft is rotating at 2/3 full rated motor speed. Prolonged operation with higher than recommended oil temperatures will adversely affect useful operating life of bearings and oil seals. Always make sure N/C connections of thermal cut out switch are wired in series with motor starting coil in control panel.

PERFORMANCE CHECK: SIZE 3CV HYDROCONSTANT

Proceed as follows if Hydroconstant fails to reach required speed or will not slow down when necessary or will not maintain proper running temperature.

1. Check and verify that the proper hydraulic, pneumatic or electric control signal at the proper strength is being sent to the control plate. If necessary, perform adjustments to bring control signals to proper strength. Check and verify heat exchanger water supply is turned on.
2. Turn off power supply to motor and check oil level. Oil level should be a minimum of 1/2 inch (12mm) above low indicator line on sight glass gage. See list at end of bulletin for proper oils.
3. Allow unit to cool to 90°F (32°C). Remove access plate (15, Fig. 7). Check and verify proper hose connection sequence (3 and 13, Fig. 7).
4. Check to see that the three bleed orifices (20, Fig. 8) in fluid coupling (21, Fig. 8) are not clogged. Using pins, carefully verify that the orifice diameters are as follows:

| Fluid Coupling Size | Nominal Motor Speed RPM | Orifice Diameter | |
|---------------------------|-------------------------------|------------------|-------|
| | | Inches | mm |
| 14A | 1750 & 1450 | 0.125 | 3.175 |
| 17A | 1750 & 1450 | 0.140 | 3.560 |

CAUTION Do not drop pins or any other objects inside fluid coupling or oil sump. Serious mechanical damage can occur if foreign objects are left inside drive.

5. Check oil pump assembly (16, Fig. 8). Verify that the roller chain (19, Fig. 8) is in place around the oil pump sprocket and the drive hub sprocket teeth. Check oil pump chain for proper tension (see Fig. 12).
6. Check mechanical operation of oil splitter assembly (2, 22 & 23, Fig. 8) by applying a signal to the speed control assembly. Make sure gear teeth are engaged. Make sure splitter arm rotates with change in control signal. If necessary, recalibrate electric speed control parts by following instructions in next section.
7. Further checking and part replacements will require disassembly. Always follow approved instructions and safety procedures when disassembling a vertical Hydroconstant.

CALIBRATE ELECTRIC SOLENOID: Proceed as follows.

WARNING

Before working on electrical equipment, insure that power to the electrical control panel is disconnected. Failure to do this may result in a fatal electrical shock.

CAUTION

Disconnect or turn off controller at control panel before disconnecting leads to solenoid. An accidental shorting of electric leads can damage equipment and cause personal injury.

1. Follow all applicable instructions pertaining to pump start-up. Allow drive to warm up to normal operating temperature. Hydroconstant must be running before solenoid can be calibrated.
2. Unscrew the locking screw in the conduit connector (12, Fig. 5) and unplug the connector.
3. Unlock the locknut at the base of solenoid (11, Fig. 5).
4. Unscrew the two set screws in the slip ring clamp (3, Fig. 5).
5. Hold the solenoid still in one hand while turning the slip ring (2, Fig. 5) CW until the output shaft speed of the drive stops increasing. Check and verify this is the full rated speed.
6. Very slowly turn the slip ring back CCW while holding the solenoid still. Adjustments must be made slowly because the drive response time can be several seconds. Stop turning when the drive output shaft starts to slow down (a 10 to 20 RPM drop).
7. When the point of initial slow down is found, record the speed and then turn the slip ring CW exactly 1/2 turn while holding the solenoid stationary.
8. Lock the solenoid in place by tightening the 2 set screws in the slip ring clamp (3, Fig. 5).
9. Tighten locknut (11, Fig. 5).
10. Loosen the set screw on the adjusting screw bracket (5, Fig. 5).
11. Using a flat blade screw driver, unscrew the spring adjustment screw (4, Fig. 5) until it stops. Do not force spring adjustment screw beyond its stop.
12. Plug the conduit connector (12, Fig. 5) to solenoid and lock (tighten screw) in place.
13. Put controller in manual voltage control mode as described by manufacturer's instructions.
14. Adjust voltage control to obtain a reading of 5 to 5-1/2 volts. (See voltmeter on controller interface.) Hydroconstant should slow down.

15. Very slowly increase the spring tension by turning the spring adjustment screw CW until the output shaft reaches the maximum speed recorded in step 7. Readjust voltage as necessary to maintain 5 volts.
16. Tighten the set screw on the adjustment screw bracket.
17. Place system controller in automatic position. (Refer to system controller instructions.)

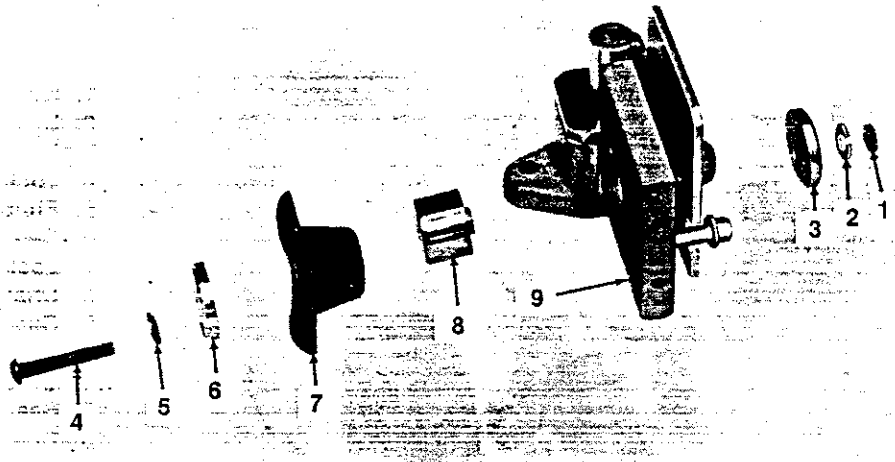

- | | |
|--------------------|----------------------|
| 1. Nut | 6. Diaphragm cap |
| 2. Lockwasher | 7. Rolling diaphragm |
| 3. Piston retainer | 8. Piston |
| 4. Screw | 9. Control bracket |
| 5. Seal | |

Figure 6. Rolling Diaphragm Replacement

DIAPHRAGM REPLACEMENT: Proceed as follows to replace rolling diaphragm:

1. Remove Control cover (see figure 1).
2. Disconnect tubing (5, figure 2) at pressure retainer (6).
3. Turn pressure control screw (7) counterclockwise to completely relax spring (8).
4. Remove four screws (9) and withdraw pressure retainer (6).
5. Disassemble in the sequence of index numbers on figure 5 to remove rolling diaphragm.
6. Coat diaphragm, piston, and bore mating surfaces with Molykote "Z" powder. Install new rolling diaphragm and reassemble in the reverse of disassembly. Piston (8) MUST be against fabric side of diaphragm (7). Diaphragm must not be kinked. It must roll freely inside the bore of control bracket (9).
7. Make certain diaphragm flange is flat against control bracket (9), and install pressure retainer (6, figure 2) and four screws (9). Tighten securely. Manually move splitter arm to make sure piston movement is free of any drag through entire length of travel.
8. Center the spring (8) on splitter arm (10) and turn pressure control screw (7) clockwise to remove slack.
9. Reconnect tubing (5) at pressure retainer.
10. Follow instructions for initial start to place in operation. Adjust pressure to proper value with pressure control screw.

NOTE: Further disassembly of piston control assembly is not required, nor is removal from the top plate. Relative positions of these parts are precisely set when assembled by the manufacturer. If altered the coupling will not operate properly.

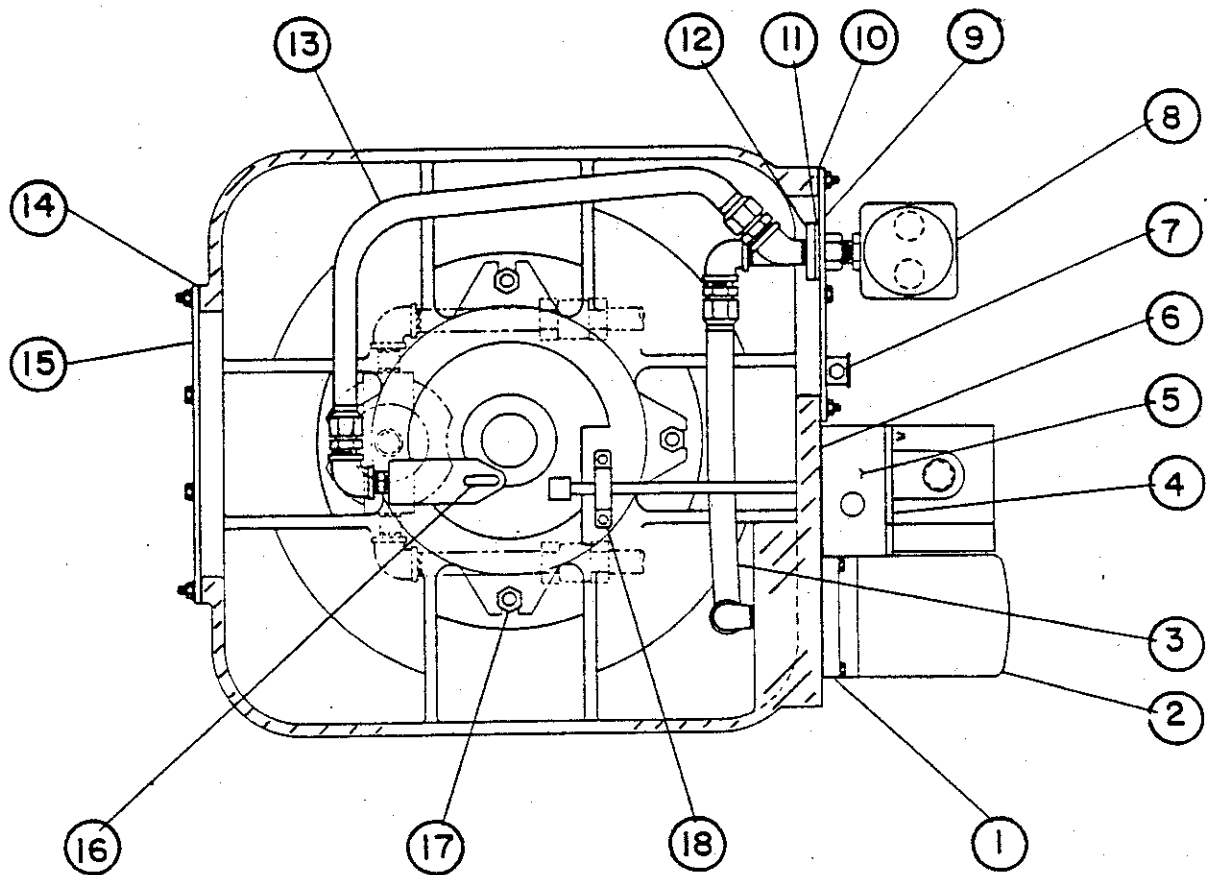

Figure 7. Hydroconstant Cross Section

- | | |
|-------------------------------|-----------------------------------|
| 1. Oil filter base | 10. Gasket |
| 2. Oil filter | 11. Heat exchanger adapter gasket |
| 3. Hose assembly | 12. Heat exchanger adapter |
| 4. Control plate | 13. Hose assembly |
| 5. Gear housing | 14. Gasket |
| 6. Gasket | 15. Access plate |
| 7. Oil level gauge | 16. Oil exit nozzle |
| 8. Heat exchanger | 17. Locknut |
| 9. Heat exchanger mount plate | 18. Pillow block bearing |

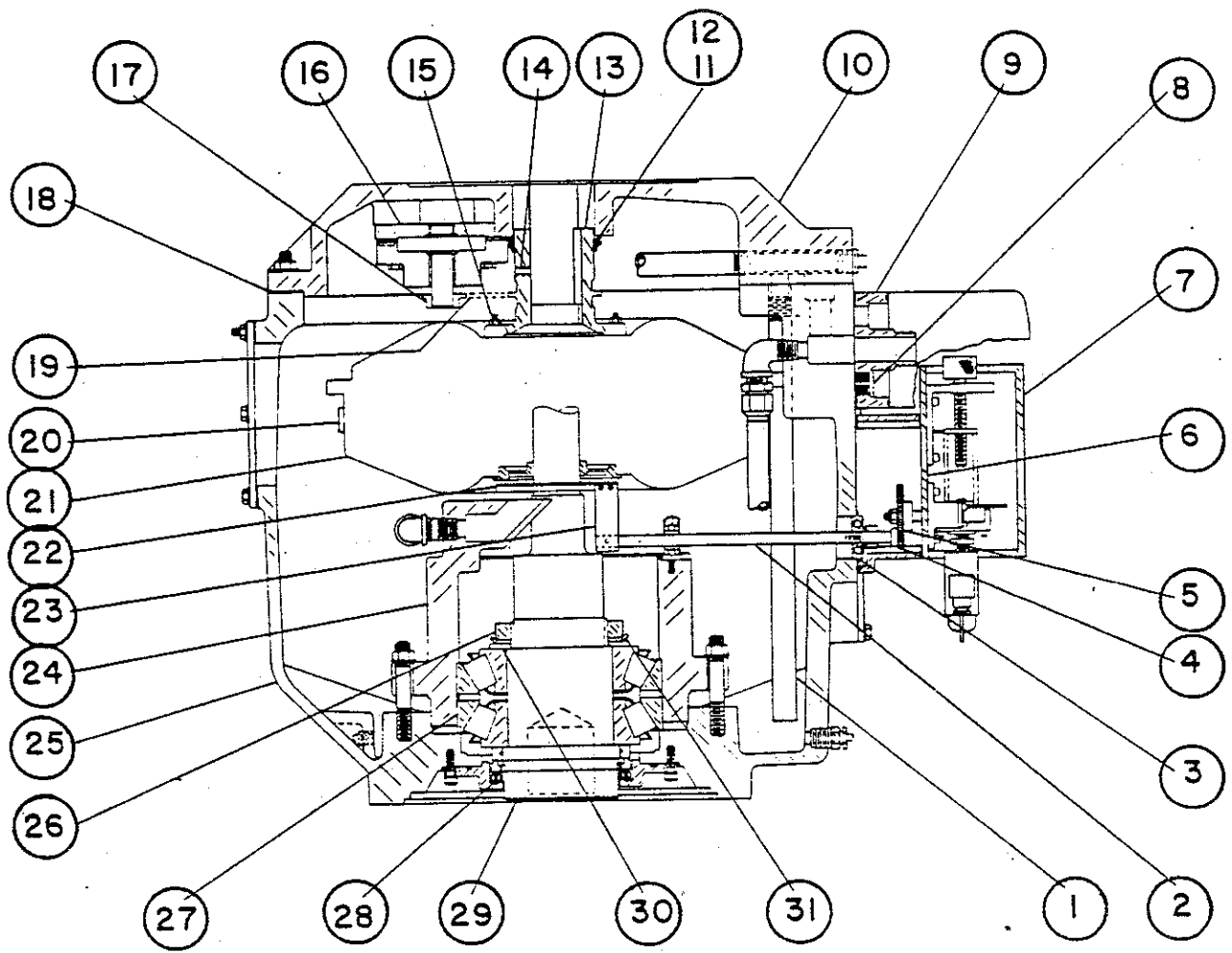

Figure 8. Hydrconstant Cross Section

- | | |
|--------------------------|--------------------------------|
| 1. Oil pump suction pipe | 16. Oil pump assembly |
| 2. Oil splitter rod | 17. Oil pump sprocket |
| 3. Support bearing | 18. Gasket |
| 4. Spur gear (21 tooth) | 19. Roller chain |
| 5. Spur gear (66 tooth) | 20. Bleed orifice |
| 6. Control plate | 21. Fluid coupling |
| 7. Control cover | 22. Oil splitter (deflector) |
| 8. Bypass valve | 23. Splitter arm |
| 9. Oil filter base | 24. Bearing cap |
| 10. Motor adapter | 25. Main housing |
| 11. V-ring seal | 26. Bearing locknut |
| 12. V-ring retainer | 27. Thrust bearing |
| 13. Drive hub | 28. Output shaft seal assembly |
| 14. Setscrew | 29. Output shaft |
| 15. Locknut | 30. Bearing spacer plate |
| | 31. Bearing lockwasher |

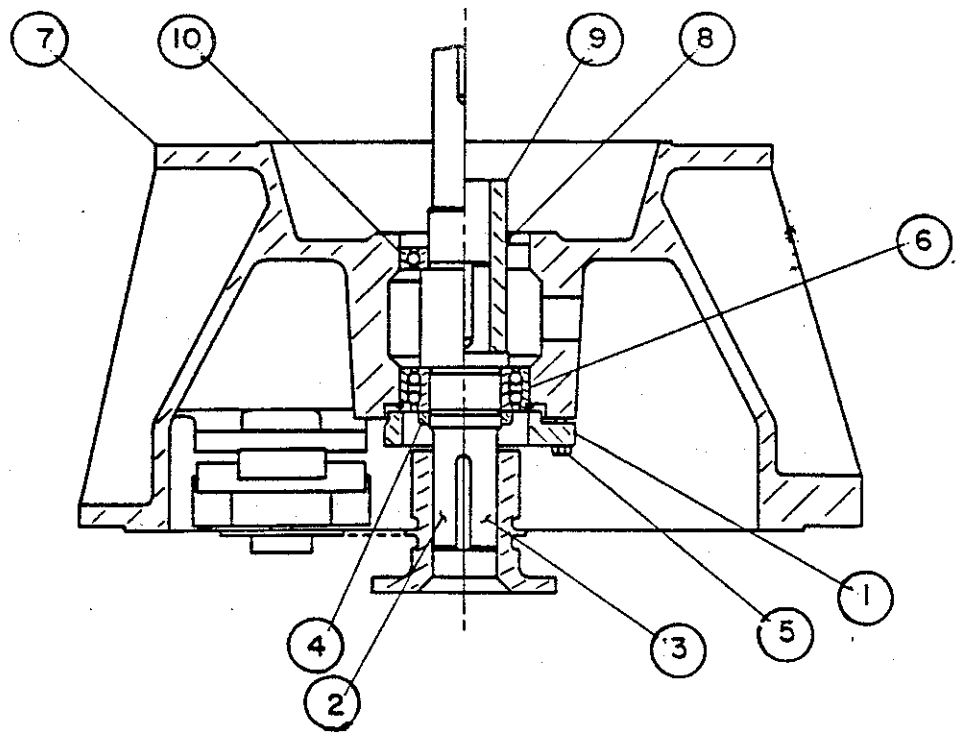

Figure 9. INPUT ENDBELL VS & VH MODELS

- | | |
|--------------------------|-----------------------------|
| 1. Bearing Cover | 6. Ball Bearing |
| 2. Input Shaft (VS only) | 7. Input Endbell |
| 3. Input Shaft (VH only) | 8. Oil Seal |
| 4. Bearing Locknut | 9. Shaft Coupling (VH only) |
| 5. Hex Head Bolt | 10. Ball Bearing (VS only) |

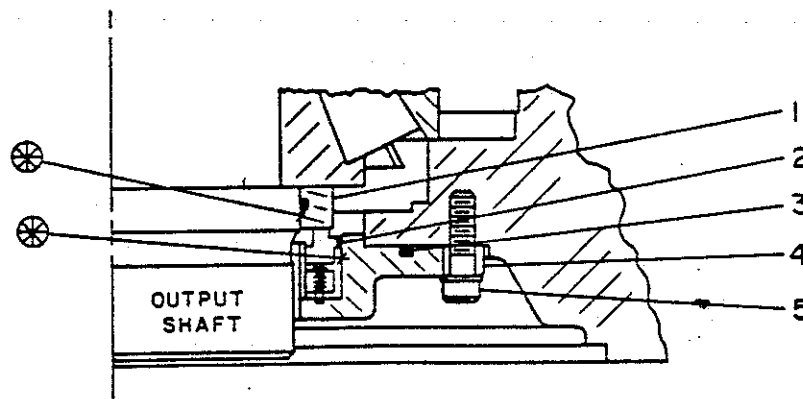

Figure 10. Output Shaft Seal Assembly

- | | |
|-----------------------|---------------------|
| 1. Seal Seat & O-Ring | 5. Socket Hd. Screw |
| 2. Oil Seal | |
| 3. O-Ring Gasket | |
| 4. Seal Retainer | |

⊗ Designated surfaces must not be damaged or nicked

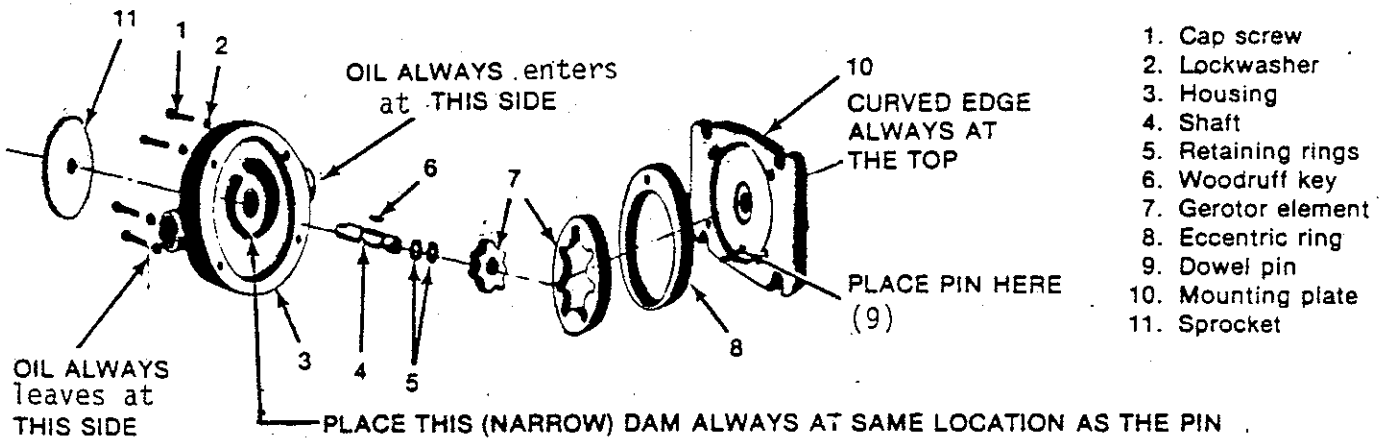

Figure 11. Oil Pump Assembly

INSTRUCTIONS FOR ADJUSTMENT OF ROLLER CHAIN TENSION

USE VERY LIGHT ("ONE POUND") FORCE TO DEPRESS CHAIN AT THE MIDSPAN WHILE MEASURING/DEFLECTION. RE-POSITION THE OIL PUMP IF DEFLECTION IS NOT AS SHOWN

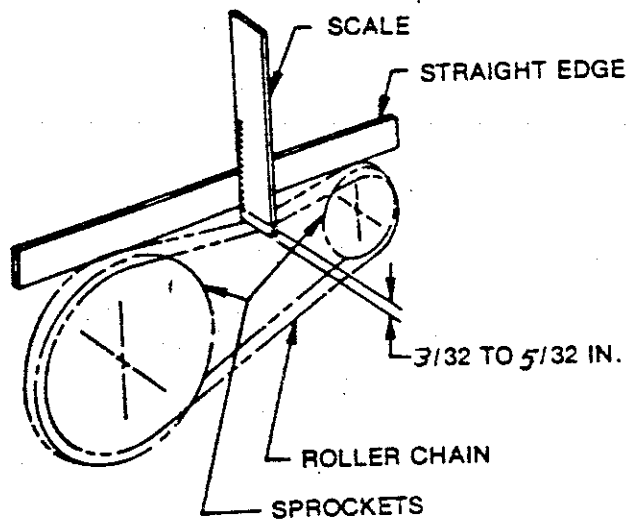

Figure 12. Chain Tension Adjustment

MAINTENANCE

PERIODIC INSPECTION: At regular intervals, inspect Hydroconstant as follows.

1. Check oil level. Oil level must be above low level mark on sight glass gauge while Hydroconstant is running.
2. Check for leaks at all pressure points; oil, around drain plugs, control plate, air breather and shaft seals; water, control pressure lines and heat exchanger.

WARNING Before working on electrical equipment, insure that power to the electrical control panel is disconnected. Failure to do this may result in a fatal electrical shock.

3. Check electrical operation of controls on control panel.
4. Check inlet strainer in cooling water line for accumulation of sediment. Clean as necessary to avoid cooling water stoppage.

HEAT EXCHANGER:

The heat exchanger may require periodic cleaning. The water side may be cleaned with water softeners or by removing the cast iron headers at the ends and cleaning the water tubes with rods or brushes. The oil side can be cleaned using a methylene chloride compound.

LUBRICATION:

The internal parts are splash lubricated by the coupling oil. Follow motor manufacturer's instructions to lubricate motor bearings. Lubricate pump bearings, if used, as instructed in bulletin furnished with pump.

OIL CHANGE:

When run continuously, oil should be drained at least once a year (9,000 hours of operation). Disconnect (shut off) power to the motor. Wait until oil temperature is below 90°F (32°C), and remove a pipe plug on low end of housing. Remove all the rest of the pipe plugs and drain all sump cavities. Clean and replace pipe plugs. Fill with new clean oil to proper level on sight glass gauge. Approximate capacity is 14 Gal. (53 liters).

OIL FILTER:

Replace oil filter every time oil is changed. Use only "Pall" model No. HC9500SUP4H (Peerless part number "2689477-000").

CAUTION Do not add or drain oil or loosen oil filter while Hydroconstant is running. Hot oil splashage can cause personal injury. Do not attempt repair or maintenance procedures or oil changes with oil temperature above 90°F (32°C). Painful and hazardous burns may result.

Acceptable Oils for Hydroconstant Use

| Supplier | Product Name |
|--------------------|---------------|
| Amoco | Rycon 68 |
| Atlantic Richfield | Duro AW 68 |
| Chevron | GST 68 |
| Shell Oil Co. | Tellus 68 |
| Exxon | Terresstic 68 |
| Standard Oil | Rycon 68 |
| Texaco | Rando HD 68 |
| Union Oil Co. | Unax AW 68 |
| Gulf | Harmony 68 |

These oils all are non-detergent mineral oils with viscosity of 68 centistokes at 100°F (38°C). All these oils have additives which give them foam and oxidation resistant properties. Other oils which are not listed but meet the same specifications may be used.

Notice: Materials of construction, specifications, dimensions, design features, and application information, where shown in this bulletin, are subject to change and/or modification without notice by Peerless Pump at their option.



LaBour
Taber

Peerless Pump Company
2005 Dr. Martin Luther King Jr. Street
Indianapolis, IN 46202
Phone: (317) 925-9661 • Fax: (317) 924-7388

A member of the Sterling Fluid Systems Group

Sterling Fluid Systems (USA), Inc.

P.O. Box 7026 • Indianapolis, IN 46207-7026
Phone: (317) 925-9661 • Fax: (317) 924-7388