

Vertical sump pumps

Types LB2A, LH2A, LB3A, LB4A

Instructions

- Installation
- Operation
- Maintenance

Read this entire book

before attempting to install, operate or repair this pump. Properly installed, our Peerless sump pump will give you satisfactory, dependable service. We urge that you read carefully these step-by-step instructions, to simplify any problems of installation, operation or repair.

Failure to read and comply with Installation and operating instructions will void the responsibility of

the manufacturer and may also result in bodily injury as well as property damage.

This book is intended to be a permanent part of your pump installation and should be preserved in a convenient location for ready reference. If these instructions should become soiled obtain a new copy from Peerless Pump. Include pump model, and/or serial number with your request.

WARRANTY

New equipment manufactured by Seller is warranted to be free from defects in material and workmanship under normal use and service for a period of one year from date of shipment; Seller's obligation under this warranty being limited to repairing or replacing at its option any part found to its satisfaction to be so defective provided that such part is, upon request, returned to Seller's factory from which it was shipped, transportation prepaid. This warranty does not cover parts damaged by decomposition from chemical action or wear caused by abrasive materials, nor does it cover damage resulting from misuse, accident, neglect, or from improper operation, maintenance, installation, modification or adjustment. This warranty does not cover parts repaired outside Seller's factory without prior written approval. Seller makes no warranty as to starting equipment, electrical apparatus or other material not of its manufacture, since the same are usually covered by warranties of the respective manufacturers thereof.

In the event, notwithstanding the terms of this agreement, it is determined by a court of competent jurisdiction that an express warranty has been given by Seller to Purchaser with respect to the head, capacity or other like performance characteristics of said equipment, Seller's liability for breach of the same shall be limited to accepting return of such equipment F.O.B. plant of manufacture, refunding any amount paid thereon by Purchaser (less depreciation at the rate of 15% per year if Purchaser has used equipment for more than thirty (30) days) and cancelling any balance still owing on the equipment.

THIS WARRANTY IS EXPRESSLY IN LIEU OF ANY OTHER WARRANTIES, EXPRESSED OR IMPLIED, AND SELLER SPECIFICALLY DISCLAIMS ANY IMPLIED WARRANTY OF MERCHANTABILITY OR FITNESS FOR A PARTICULAR PURPOSE.



Peerless Pump Company
2005 Dr. Martin Luther King Jr. Street
Indianapolis, IN 46202
Phone: (317) 925-9661 • Fax: (317) 924-7388

2899981
REV 12/76

IMPORTANT SAFETY PRECAUTIONS

Pump parts, and the tools and rigging equipment used in installation, are heavy and may easily cause personal injury if dropped or carelessly handled. The normal precautions and safety rules associated with the erection of heavy machinery, in regard to manual lifting, use of power equipment, and handling of tools, must be observed in the installation of this pump.

Petroleum-base cleaning solvents are flammable. Open flame or smoking by personnel in the vicinity of these solvents is extremely hazardous and must not be permitted.

Do not work under a suspended object unless there is a positive support under it to stop its fall in event of sling or hoist failure. Disregard of this warning could result in grave personal injury.

Before handling any wiring or performing any wiring connections, be certain that the electric power supply source is shut off. An electrical shock from contact with live wires or leads can be fatal.

Due to automatic switch or controller operation of sump pumps, tie the main disconnect switch open or remove fuses from main lines before attempting lubrication, mechanical and electrical examinations, or repairs. Attach a card "DO NOT CLOSE SWITCH - PUMP REPAIR IN PROGRESS". Disregard of this warning may result in serious personal injury or death.

One piece shafts are up to 15 feet long and are heavy. Provide good support and use care while withdrawing [inserting] to keep from bending.

WARNING

The pumps described in this bulletin must not be installed in any manner except as specified herein, and must be operated at intermittent duty service only for dewatering service of usual sump or bilge nature within corrosion limits of standard materials of construction. Maximum temperature of fluid handled must not exceed 90°F [32°C]. Pumping element must be submerged at all times. The pumps described in this bulletin are also subject to limitations and notes attached to the following Pump Data table. Violation of this warning will void the warranty and may result in serious property damage or grave personal injury.

PUMP DATA

Pump Type	Discharge Connection NPT (45° Elbow)	Intermediate Bearing Interval, Ft	Minimum Basin Sizes, Inches				
			Discharge above Floorplate		Discharge below Floorplate		
			Simplex	Duplex	Simplex	Duplex	
			Round or Square	Round or Square	Round or Square	Round	Square
LB2A	2	(2)	24	36	X	X	X
LH2A	2	4.0 (2)	30	36	48	60	48
LB3A	3	6.0 (3)					
LB4A	4						

- Notes:
- (1) Maximum speed for all types: 1750 rpm.
 - (2) Medium to heavy duty applications.
 - (3) Light duty applications.

INTRODUCTION

UPON RECEIPT OF SUMP PUMP: Check carefully to see that all of the equipment has been received. Report immediately any shortages or damages to the transportation company handling the shipment noting the extent of the damage or shortage on the freight bill and bill of lading.

Do not leave the unit exposed to weather or construction hazards. The pump may become mechanically damaged. This pump is a well designed and carefully manufactured unit. It should be given the same attention accorded to any precision machine.

The satisfactory operation of a pump depends to a large extent upon proper installation. These instructions cannot answer every question that may arise as each installation will be different. The installer and

the operator of this equipment must use good judgement to adapt these procedures to the installation.

INSTALLATION

WARNING

Pump parts, and the tools and rigging equipment used in installing pumps, are heavy and may easily cause personal injury if dropped or carelessly handled. The normal precautions and safety rules associated with the erection of heavy machinery, in regard to manual lifting, use of power equipment, and handling of tools, must be observed in the installation of this pump.

LOCATION: Install the sump pump where it will be accessible for inspection and maintenance. Observe the following;

1. Locate the receiver (basin) and pump so that liquid flows into the basin by gravity.
2. Install basin so that the basin cover is not below grade level. If below grade level, water may collect on the cover.

SETTING BASIN: Dig a pit of sufficient depth and diameter to accommodate the basin and pipe connections. Note the following:

1. If pit bottom is soft or soggy, prepare a gravel or concrete slab (or equivalent bed) to support basin.
2. Set the basin on the bed, turned to orient the pump discharge connection properly. If necessary, level basin with wedges or shims.
3. Fill the space around the basin with firmly tamped gravel, or similar material.

BASIN COVER: Set the basin cover on the basin, locating pump discharge connection as required. Use a pliable, non-hardening sealer at the split (if that type cover is used) and install and tighten flange bolts. If a basin cover with manhole or access hatch as shown in figure 1 is used, the cover may be permanently set before pump installation.

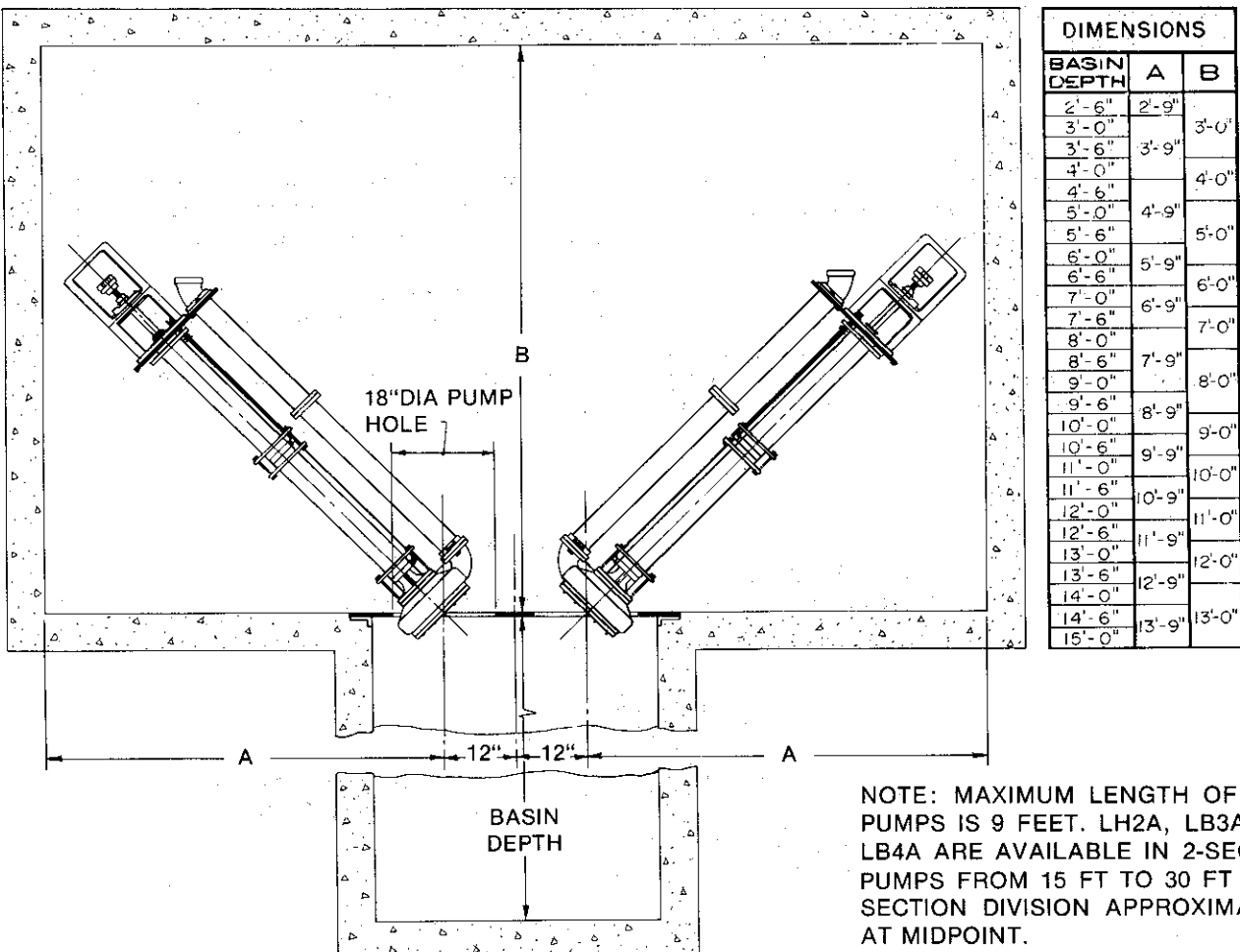

Figure 1. Pump Room Clearance for Installation and Removal of Vertical Sump Pumps

CAUTION The pump impeller must rotate in the direction shown by the arrow on the discharge casing.

WARNING Make certain that power supply disconnect switch is tied open, or fuses have been removed from the load side, when making connections to an electric motor. Failure to observe this warning could result in fatal electrical shock.

MOTOR ROTATION: Prior to setting the pump in the basin check the direction of rotation of three phase motors as follows:

1. Temporarily connect motor leads to power source.
2. Momentarily energize motor to just start turning.
3. Observe that motor rotation is clockwise when looking at end of motor opposite shaft extension.
4. If rotation is not correct, assure disconnection of power supply, then interchange any two leads to the motor. Reconnect power supply and repeat step 2 to check rotation again.
5. Mark the leads and power supply to identify for permanent connection later.
6. Disconnect power supply.

PUMP INSTALLATION: Flush the drainage system with water and clean the basin. Foreign material occasionally found in new systems could damage or plug the pump if not removed.

For One-Section Pump:

1. If a cutless rubber casing bearing is used on LH2A, LB3A or LB4A models, the lower Caplug plug (41, figure 6) in the hanger pipe (22) just above the

discharge casing (29) should be removed to allow this opening to act as a flushing relief port for the clear water supply which lubricates the rubber bearing.

WARNING Do not work under a suspended object unless there is a positive support under it to stop its fall in event of sling or hoist failure. Disregard of this warning could result in grave personal injury.

2. Using a suitable hoist or lifting means, ease the unit slowly through the basin cover hole (see figure 1) and lower the pump into the basin.
3. To block moisture and gas exchange between the basin pool and surrounding areas, the pump floor plate should be sealed to the basin cover as shown in figure 2.
4. Check for proper position of discharge pipe connection.
5. Secure the pump floor plate to the basin cover with cap screws.

For Two-Section Pump: Two-section sump pumps are shipped with motor and upper and lower sections separated. The sections are usually marked for proper assembly at installation. If not marked, align the grease line holes in the companion flanges when joining the sections. Proceed as follows:

1. Apply a little clean light oil on the O-ring (34, figure 6) and end of the discharge pipe. If not already done, round-off the pipe end with a file.
2. With a rotary push, insert the lower discharge pipe section into the packing flange (35).
3. Temporarily secure discharge pipe to lower section of pump.

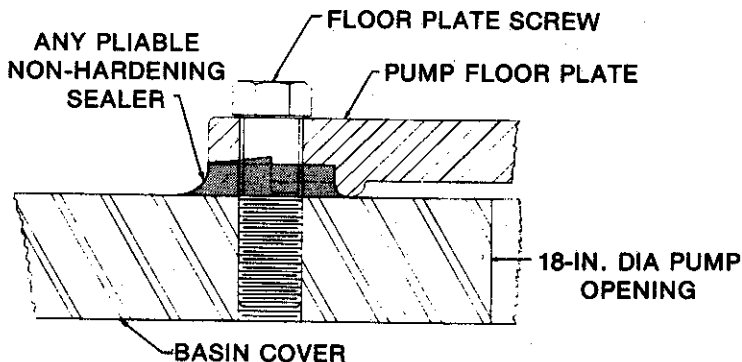

Figure 2. Sealing Pump Floor Plate

4. If a cutless rubber casing bearing is used on LH2A, LB3A or LB4A models, the lower Caplug plug (41) in the hanger pipe (22) just above the discharge casing (29) should be removed to allow this opening to act as a flushing relief port for the clear water supply which lubricates the rubber bearing.

WARNING

Do not work under a suspended object unless there is a positive support under it to stop its fall in event of sling or hoist failure. Disregard of this warning could result in grave personal injury.

5. Lower the bottom section of pump and discharge pipe into the sump and set to one side.

6. Screw upper section of discharge pipe into discharge elbow (78, figure 7).

7. Lower the upper section of the pump into position and rest on 4-inch blocks between the pump floor plate (19, figure 6) and basin cover.

8. Move the lower section into position, aligning match marks (or grease line holes).

9. Rotate shaft to align taper pin (75, figure 7) hole with hole in coupling (76). Raise lower section to engage coupling and secure with screws (45, figure 6) and washers and nuts (42). Do not tighten nuts at this time.

10. Turn shaft to align hole for taper pin (75, figure 7), insert pin and tap to seat solidly. Install caplugs (41) in hanger pipe (22).

11. Tighten nuts (42, figure 6) securely.

12. Make sure that rubber gasket is between discharge pipe flanges, align screw holes and attach screws and nuts, tightening securely.

13. Rotate shaft (2) by hand to check that there is no rubbing of impeller. If impeller rubs, refer to step 12 of Assembly for clearance adjustment.

14. Install grease lines and grease fittings.

MOUNTING MOTOR: Install keys in slots of motor and pump shafts. Slide motor half coupling (55, figure 6) on motor shaft and pump half coupling (56) on pump shaft, temporarily holding with set screws (58).

1. Install coupling flexible member (57) in pump coupling half. Flexible members may be in two parts with wire ring or in single part with side split.

2. Clean mounting surfaces of motor flange and bearing pedestal or motor adapter (1, figure 5 or 6).

3. Set motor on the adapter, aligning and engaging motor half coupling with flexible member. When

motor is seated in adapter, turn shaft by hand. If no binding, install and tighten motor screws securely.

4. Loosen set screws (58, figure 6) as required and slide half couplings toward each other to completely engage flexible member. Tighten set screws securely.

5. Connect motor leads as previously marked, using flexible conduit at the motor.

PIPING: The discharge pipe line of the pump should include a union, a horizontal swing check valve, and a gate valve, all near the pump. The line should be run to a point above the sewer level so as to drop into the sewer from above. This arrangement permits easy removal of the unit for repairs or cleaning and helps to prevent sewer water backing up through the discharge pipe.

The discharge pipe should not be smaller in size than the discharge connection on the pump. Where runs are long, they should be at least one or two sizes larger.

It is important that the pipe connections to the unit be so made that there is no pipe strain upon the pump.

FLOAT CONTROLS: The float control (when furnished) provides automatic operation of the pump unit.

On liquid level rise the float raises the float rod with its fixed buttons until the lower button trips the float switch, starting the pump. As the liquid level drops, the upper float button trips the switch to the off position, stopping the pump.

When the pumping unit consists of two pumps (duplex installation) in a common receiver it is desirable to provide automatic alternation of the pumps. Alternate operation of the pumps insures equal wear and keeps both units in good running condition.

Alternating control provides alternate operation of the two pumping units on successive cycles as long as a single pump can handle the pump load. However, under peak flow conditions, when the liquid level continues to rise more rapidly than can be handled by one pump, both units are automatically placed in operation.

INSTALLING AND REGULATING THE STANDARD FLOAT CONTROL: Locate the float mechanism where provided for on the floor plate or basin cover. This should be so arranged that the float is not disturbed by strong water currents and the moving element is able to rise and fall freely.

The usual float switch equipment consists of a float rod, float, guide pipe for float rod, switch stand assembly and float rod adjusting buttons.

1. Float rod button
2. Hollow head set screw
3. Float rod
4. Float rod seal housing
5. Hex head cap screw
6. Reducing pipe coupling
7. Float rod guide pipe
8. Float
9. Float lock nut
10. Float rod bushing
11. Switch stand assembly
12. Lock washer (2)
13. Round head machine screw (2)
14. Float switch
15. Felt washer
16. Cap

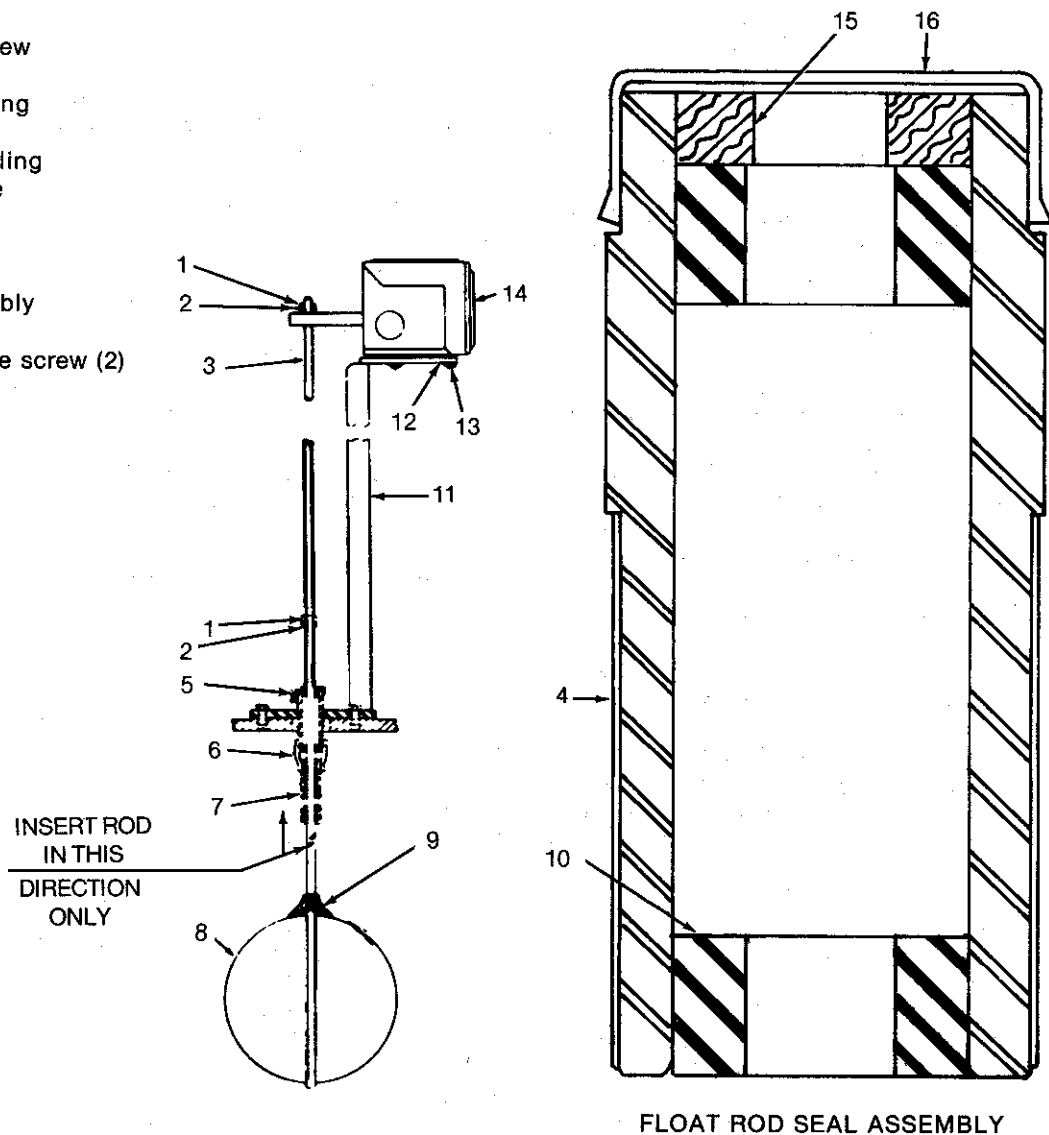

Figure 3. Float Rod Installation

1. Fasten the switch stand assembly (11, figure 3) to the floor plate or basin cover over the hole provided.
2. Insert the top section of bare float rod (3).
3. Slip one button (1) onto the top of the rod, insert the top end of the rod up through the float switch (14) lever eye and suspend the rod on the seal assembly by fixing this button (1) temporarily on the float rod just above the float rod seal.

There may be more than one set of float rod and guide pipe sections. They must be installed in alternate sections (of rod then guide pipe) for the entire quantity furnished before attaching the float.

4. From below the basin cover, screw on the float lock nut (9) and then the float (8), tightening them against each other as a jam lock.

6

5. To maintain prime and insure maximum efficiency of the pump, adjust the top button to trip the float switch (down position of lever arm) at a water level just above the top of the discharge casing. At this low water limit or shut-off point, the bottom button should be set on the float rod at least 1 inch above the seal assembly, if the maximum high-low water differential setting is desired. The operation levels for the pump should be so adjusted that it runs at reasonable intervals.

Peerless Pump has three types of automatic alternation available: electric alternating float switch, mechanical cam type rod alternators, and manual transfer sleeves. If your installation is furnished with one of these and an instruction bulletin is desired, request Peerless Pump bulletin entitled "Float Controls and High Water Alarms for Sump and Sewage Pumps".

CONTROLS: If the motor horsepower and current fall within the rating of the float switch, an automatic across-the-line type magnetic starter is generally not required for single phase installations, depending on applicable local and national electrical codes and requirements of the local power company. In any three phase installation the float switch is only used to pilot a magnetic starter which is furnished by the installer.

It is recommended that a suitable overload protector, or an across-the-line automatic starter be installed in the motor circuit to prevent motor burn-outs if an overload should occur. The float switches provided will not protect a single phase motor circuit from overloads.

FUSES: It is recommended that Fusetron (dual element) fuses be used if no other thermal or motor overload protecting device is used. Care must be taken in selecting the proper size Fusetron. When a fuse blows it indicates that something is wrong,

either in the motor, pump, switch, fuse rating or service. Do not replace a fuse until you find and remove the cause of the blowout.

WARNING Before handling any wiring or performing any wiring connections, be certain that the electric power supply source is shut off. An electrical shock from contact with live wires or leads can be fatal.

WIRING: Connect the electric service to the controls and make inter-control electrical connections when necessary according to wiring instructions accompanying the switches; using conduit and wire sizes as required by local and national codes. Typical wiring diagrams are illustrated in figure 4. A length of flexible conduit should be used adjacent to the motor for convenience in pump or motor repair. Be sure the voltage and frequency indicated on motor nameplates are the same as those of the service provided.

LUBRICATION

WARNING Due to automatic switch or controller operation of sump pumps, tie the main disconnect switch open or remove fuses from main lines before attempting lubrication, mechanical and electrical examinations, or repairs. Attach a card "DO NOT CLOSE SWITCH - PUMP REPAIR IN PROGRESS". Disregard of this warning may result in serious personal injury or death.

BALL THRUST BEARING: The thrust bearing for type LB2A pump requires no lubrication. This bearing is charged and sealed with lifetime supply. The other models have a ball thrust bearing located in the pedestal, below the motor coupling. Lubricate separately through a zerk alemite fitting located in the bearing cap. In general the bearing should be lubricated every three to six months, depending upon service. ALWAYS GREASE SPARINGLY. Use a high grade Lithium soap base grease meeting National Lubricating Grease Institute Grade 2 specification.

SLEEVE GUIDE BEARINGS: Sleeve guide bearings for the type LB2A pump are self lubricating. Lubrication for sleeve guide bearings on other models is provided through separate grease lines. It is recommended that bearings be lubricated with any of the following lubricants or approved equal: Arco

Litholine EP-1 Grease, or Shell's Alvania EP. The bearings should be greased before starting the pump, and at weekly intervals thereafter, depending on service. Standard units are fitted with zerk alemite fittings located on the pump pedestal at the pump floor plate.

CUTLESS RUBBER CASING BEARING: Rubber casing bearings are generally furnished on LH2A, LB3A and LB4A models when the liquid being pumped contains some sand or other similar abrasive materials.

Pumps furnished with lower rubber casing bearings are provided with stainless steel shafts. Do not use a rubber casing bearing with a steel pumpshaft.

If pump shaft is supplied with Cutless rubber bearings, provide a supply of clear water to the lower bearing (first above discharge casing). This line is usually supplied without a grease fitting at the floor plate and is tagged to indicate that a clear water supply is needed. Adjust the supply at 3 to 5 psi above the pump discharge pressure.

FLOAT ROD SEAL HOUSING: At approximately weekly intervals, lubricate the float rod seal assembly (figure 3) felt washer saturating it with SAE 30 oil.

OPERATION

WARNING Due to automatic switch or controller operation of sump pumps, tie the main disconnect switch open or remove fuses from main lines before attempting lubrication, mechanical and electrical examinations, or repairs. Attach a card "DO NOT CLOSE SWITCH - PUMP REPAIR IN PROGRESS". Disregard of this warning may result in serious personal injury or death.

1. Turn shaft by hand and see that it rotates freely. Failure of shaft to turn freely may be caused by packing gland being too tightly drawn or by impeller binding in casing (refer to instruction on how to adjust impeller, maintenance).

2. See that voltage and frequency on motor nameplate are the same as service provided.

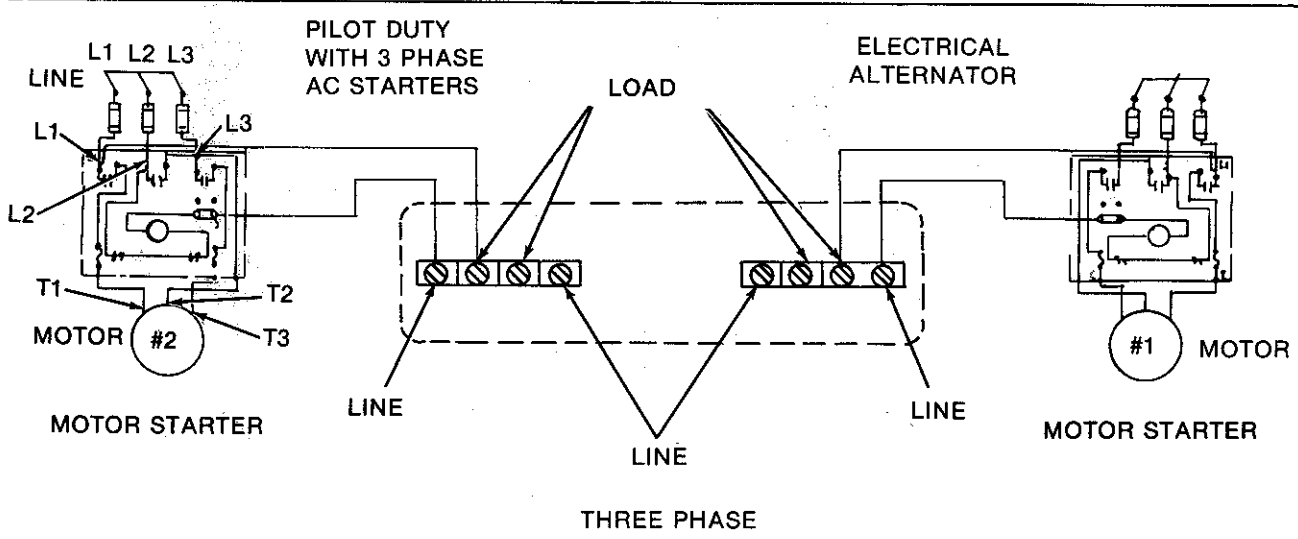
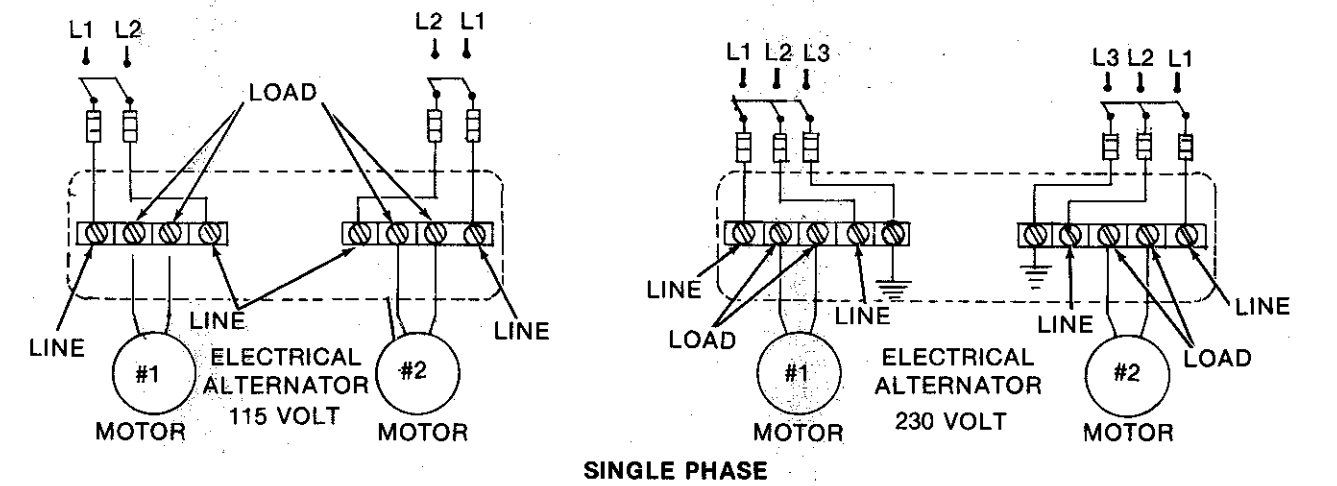
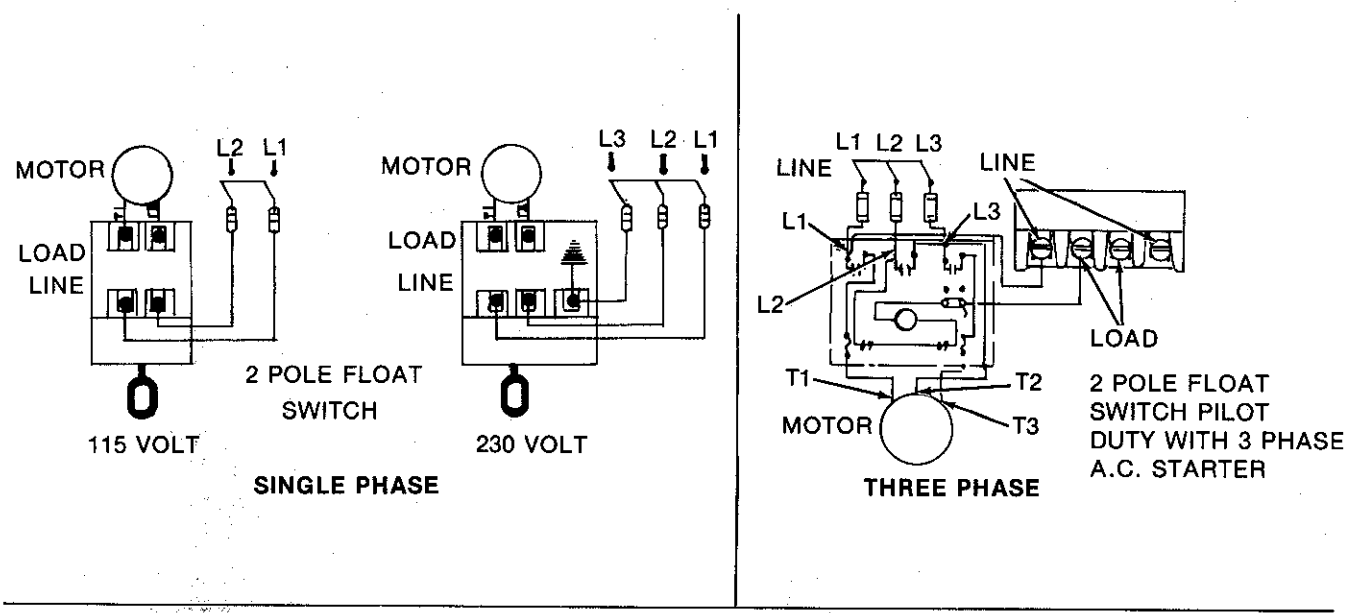

Figure 4. Typical Control Wiring Diagrams

3. Most motors are of the dual voltage type. Be sure motor leads are wired for the voltage used.
4. See that the proper fuses are installed.
5. See that switches are regulated for operation and that thermal units are "set".
6. Check motor rotation direction by momentary switch contact. Motor must rotate in same direction as arrow indicated on pump floor plate.

STARTING: Close the discharge gate valve fully, reopen just a small amount (a 'crack') and close the motor disconnect switch. The pump will not operate unless the float control switch is closed. If a manual bypass circuit switch has been used, the pump may be run independently of the water level controls by turning it to "on" or manual position.

AFTER STARTING: Note the following:

1. Slowly open the discharge gate valve.
2. Note operation of the float control mechanism. Observe a complete start-stop cycle for freedom of float. See that the float switch closes and opens properly as basin fills and is emptied by the pump. The operation of the unit should be absolutely automatic.
3. See that pipe connections do not leak.
4. See that the pump and motor rotate in a clockwise direction when looking down on the motor.
5. Observe operation of pump closely for the first day and at regular intervals for ten days. A new machine is frequently stiff and tight, and therefore the unit should be watched to note performance.

MAINTENANCE

TROUBLESHOOTING: The following troubles may occur. To correct trouble check for the possible causes given.

WARNING Due to automatic switch or controller operation of sump pumps, tie the main disconnect switch open or remove fuses from main lines before attempting lubrication, mechanical and electrical examinations, or repairs. Attach a card "DO NOT CLOSE SWITCH - PUMP REPAIR IN PROGRESS". Disregard of this warning may result in serious personal injury or death.

- d. Control switches worn or arcing.
- e. Motor windings grounded or internal centrifugal switch malfunctioning.
- f. Motor overloading.
- g. Discharge head is lower than anticipated.

3. Pump Runs Continuously:

- a. Check pump rotation.
- b. See if check valve in discharge line is stuck.
- c. Check discharge head, see if beyond pump rating.
- d. Check inflow rate to basin; see if inflow is excessive.
- e. See if shaft is intact and if the impeller rotates.
- f. Check to see if pump is air bound.
- g. Check float and float switch assembly.

CARE OF EQUIPMENT: Life of a sump pump can be considerably prolonged by following a few simple rules:

1. Maintain proper adjustment of the packing gland; change packing when deteriorated.
2. Keep inside and outside of motor and controls free of moisture, oil and dirt. If necessary, blow out their interiors with a bellows. If switch contacts become corroded or pitted they should be smoothed and treated with vaseline, or replaced.
3. See that the pump does not stand idle for very long periods. If necessary, start pump manually to see that the shaft is free.
4. Follow lubrication instructions.

1. Pump Fails to Operate:

- a. Shaft binding or impeller blocked.
- b. A blown fuse, tripped or loose thermal unit.
- c. Switch contacts corroded, circuit shorted, or connections broken somewhere in circuit.
- d. Wiring hook-up or service provided incorrect, or switches not "set" for operation.
- e. Motor windings grounded or internal centrifugal switch malfunctioning.
- f. Electric or phase failure.
- g. Float control mechanism not functioning, or float water-logged.
- h. Float rod buttons may be improperly adjusted or slipping on float controlled pumps.

2. Blown Fuse, Tripped Thermal Unit:

- a. Fuse or thermal unit used of incorrect rating or surrounding area too hot.
- b. Shaft stuck or not rotating freely.
- c. Loose or broken connection somewhere in circuit.

PERIODIC INSPECTION: Reread WARNING at the beginning of this Maintenance section. To insure the best operation of the pump, make a systematic inspection at least once a week, and check the following:

1. See that the pump starts and stops when the float or controller makes or breaks contact, and that the pump empties the sump.
2. See that the float mechanism or controller responds properly to rising and falling water levels in the sump.
3. See that the motor comes quickly up to speed, and maintains a constant rotation rate.
4. See that the operation of the pump is not excessively noisy.

PACKING RENEWAL: Packing for type LB2A consists of two rings, Anchor No. 524, and three rings, Anchor No. 118. Rings No. 524 are 1/8 inch thick, are harder than No. 118, and must always be installed on top of the packing box. Packing for other types consists of three rings of Garlock No. 235, 3/8-inch square packing. The packing is cut on one side to slip around the pump shaft. Never add one or two rings of packing on top of old packing. If packing can no longer be taken up by the packing gland adjustment, complete repacking is required.

Remove all old packing.

When replacing packing, ring joints must be staggered.

Packing should be drawn up only snug.

Rotate shaft occasionally when packing the pump to insure free movement.

WARNING Tie the disconnect switch open or remove fuses from lines before attempting to remove pump from the basin. Attach a card "DO NOT CLOSE SWITCH - PUMP REPAIR IN PROGRESS." Disregard of this warning may result in fatal electrical shock.

REMOVAL: Remove the sump pump in the following manner (see figure 1):

1. Shut off or blank the system drain (inflow) line to the basin.
2. Close the gate valve in the discharge line.
3. Open disconnect switch at power supply. Tie switch open and attach card to prevent closing accidentally.
4. Disconnect the union or flange of the discharge pipe above the floorplate.

For type LB2A pump (see figure 5):

1. Unbolt and remove motor from bearing pedestal (1).
2. Remove coupling flexible member (57, figure 6), loosen set screw (58) and slide off pump half coupling (56). Remove Woodruff key (3, figure 5) from shaft.
3. Remove mounting bolts from pump floor plate (33).
4. Lift pump out of receiver and lay across saw horses or other suitable support to facilitate disassembly.

For one section pump models LB3A, LB4A and LH2A (see figure 6):

1. Remove cap screws (8) and nuts (11). Remove motor with motor adapter (1) and set to one side. (motor coupling half (55) should separate from the coupling flexible member (57) as the adapter and motor are withdrawn.)
2. Remove coupling flexible member (57), loosen set screw (58) and slide off pump half coupling (56). Remove key (3) from shaft.
3. Remove the cap screws attaching the floor plate (19) to the basin cover and lift pump from basin.
4. Lay across saw horses or other suitable support to facilitate disassembly.

WARNING Do not work under a heavy suspended object unless there is a positive support under it to stop its fall in event of sling or hoist failure. Disregard of this warning could result in grave personal injury.

For two-section pump models LH2A, LB3A and LB4A (see figures 6 and 7): Drain, or bail, all liquid from the basin. Proceed as follows:

1. Block pump up with a suitable support between discharge casing and basin floor to hold the lower section firm while dismantling it from the upper section.
2. Disconnect and remove all grease line tubing to prevent damage when handling the pump. Be sure to mark grease lines to facilitate reassembly. Plug all grease line openings so that no dirt gets into lines and bearings.

NOTE: Mark all hanger pipe connections so that they may be reassembled in their original positions in relation to their positions to the grease lines and locations in the pump column.

3. Remove the two cap plug protectors (41, figure 7) from the hanger pipe (22). The two cap protectors are located 180° apart and are at the point where the shaft is coupled together near the middle of the pump.

4. Turn the upper shaft (74) until the small end of the taper pin (75) in the shaft coupling (76) is in line with one of the holes in the hanger pipe.

5. Drive the taper pin from its small end until it can be removed from the opposite hole in the hanger pipe.

6. Remove cap screws (7, figure 6) from the bearing cap (6). Do not disturb setting of lock nut (4) and bearing adapter (5).

7. Raise shaft approximately 4 inches so that the lower end of the upper shaft (74, figure 7) clears the top of the coupling (76). Block in place with a 4 inch piece of wood between the bottom of the bearing (9, figure 6) and the bearing pedestal (12) to keep shaft in a raised position.

8. Unbolt the flange connection in the pump discharge line at point B (figure 7) and temporarily secure to the hanger pipe.

9. At hanger pipe A, which is the joint closest to the opening left by the removal of the caplug plug (41), remove bolts (45, figure 6) and nuts (42) joining hanger pipe and intermediate bearing assembly, and remove lower section of pump.

10. Remove lower section of discharge pipe (77, figure 7) from packing flange (35, figure 6) by using a pulling twisting motion.

11. To remove upper section of discharge pipe from discharge elbow (78, figure 7) unscrew with counter-clockwise turns as viewed from point B.

12. Remove separated upper and lower sections of the pump from the basin. Lay across suitable supports or saw horses.

DISASSEMBLY: For type LB2A pump (see figure 5)

1. Remove Esna nut (4) from shaft (2).

2. Unscrew set screw (6) from bearing adapter (5). Note that dog point of screw seats in the milled slot provided in the pump shaft (2).

3. Unscrew socket head cap screws (7) and remove bearing cap (8).

4. Slide off bearing assembly unit (8, 29 & 30) from the shaft.

5. Remove screws (9) from packing plate (10).

6. Remove screws (27) and remove suction casing (25).

CAUTION One piece shafts are up to 15 feet long and are heavy. Provide good support and use care while withdrawing to keep from bending.

7. Remove the impeller (24) and shaft (2) from the pump by first pushing the shaft at the coupling end until the impeller clears the discharge casing (23). When clear, pull shaft free of pump from impeller end. Retain packing plate (10).

8. Unscrew nuts from studs (15 and 20) and bolts (17) to remove hanger pipes. Pumps built for basins 3 feet deep or less have only one hanger pipe assembly.

9. Remove discharge pipe (34) from discharge elbow (31) by using a twisting and pulling motion.

10. Remove hanger pipes (16) and packing box (11).

11. Bearing pedestal (1) may be removed by unscrewing nuts (14).

12. To remove ball bearing (29) from adapter (5) pry retaining ring (30) from slot in adapter. When pried loose slide off ring and slip bearing from adapter.

13. To remove impeller (24) from shaft (2) loosen set screw (21), remove cap screw (36), (37) and impeller washer (22) and slide impeller off. When clear, remove key.

14. Packing rings (32) in discharge casing (23) and discharge elbow (31) may be pried out with a screw driver.

15. To remove the sleeve bearings (19) use hammer and drift.

16. Remove packing (13) from packing box (11). Refer to Packing Renewal under maintenance.

For types LB3A, LB4A and LH2A (see figure 6):

Mark hanger pipe (22, figure 6) flanges prior to disassembly for grease line (21) locations, and proper hanger pipe location (hanger pipes are usually not the same length).

1. Remove cap screws (31) and suction cover (30) (strainer (54) when present). Block impeller (28) to keep shaft (2) from turning.

2. Remove packing plate (18) and packing (17).

3. With 7/8-inch open end wrench, remove nut (4) by turning in a counter-clockwise direction as viewed from coupling end.

4. Remove bearing cap (6) by removing screws (7).

5. With spanner wrench, unscrew bearing adapter (5) with its bearing (9) from its seat in the bearing pedestal by turning in a counter-clockwise direction as viewed from the coupling end.

CAUTION One piece shafts are up to 15 feet long and are heavy. Provide good support and use care while withdrawing to keep from bending.

6. Remove impeller block. Shaft and impeller assembly are now free to be removed from the pump. Withdraw from casing end.

7. With a 5/8-inch thin wall socket wrench, unscrew impeller nut (27) by turning counter-clockwise (as viewed from bottom of pump).

8. Remove grease lines (21).

9. To remove discharge casing (29), remove nuts (38) or capscrews (39B) holding hanger pipe assembly (22), nuts (33), screws attaching flange (35) to the discharge casing.

10. With a pulling twisting motion, withdraw discharge pipe from discharge elbow (52).

11. With a pulling twisting motion, remove packing flange (35) from discharge pipe (48).

1. Bearing pedestal
2. Shaft
3. Woodruff key
4. Esna nut
5. Bearing adapter
6. Set screw
7. Socket head cap screw
8. Bearing cap Assy.
9. Socket head cap screw
10. Packing plate
11. Packing box
12. Pedestal gasket
13. Packing set
14. Nut
15. Stud
16. Hanger pipe Assy.
17. Hex. head bolt
18. Bearing housing
19. Bearing
20. Stud
21. Set screw
22. Impeller lockwasher
23. Discharge casing
24. Impeller
25. Suction casing
26. Washer
27. Hex. head cap screw
28. Strainer
29. Ball bearing
30. Retaining ring
31. Discharge elbow
32. Ring gasket
33. Floor plate
34. Discharge pipe
35. Gasket
36. Impeller screw
37. Grease fitting

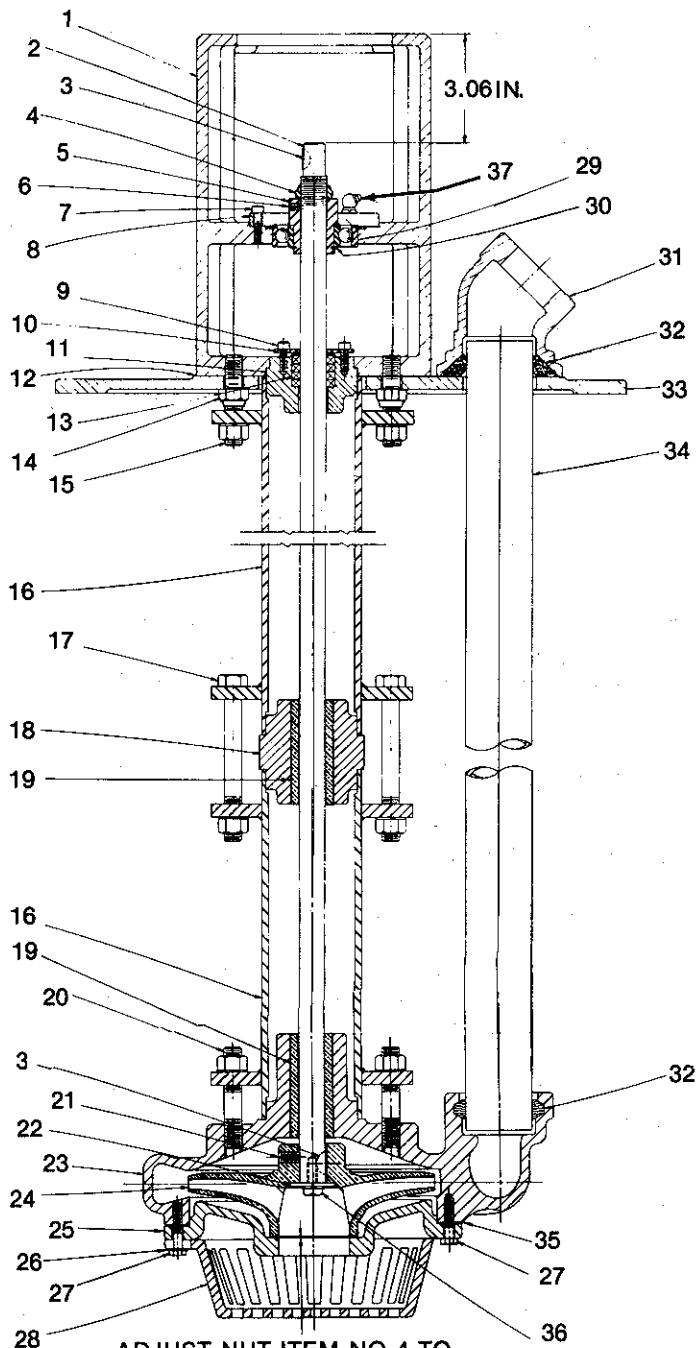

ADJUST NUT ITEM NO 4 TO
OBTAIN 0.012-0.015 CLEARANCE
BETWEEN IMPELLER AND SUCTION CASING

Figure 5. Type LB2A Sump Pump

1. Motor adapter
2. Shaft
3. Pump coupling key
4. Elastic stop nut
5. Bearing adapter
6. Bearing cap
7. Hex head cap screw
8. Hex head cap screw
- *9. Ball bearing
10. Snap ring
11. Hex nut
12. Bearing pedestal
13. Grease fitting
14. Connector and neoprene grommet
- 15A. Hex head cap screw
- 15B. Stud
16. Socket head cap screw
- *17. Packing set
18. Packing plate
19. Floor plate
20. Hex nut
21. Grease line
22. Hanger pipe assembly
23. 90° male elbow
- *24. Shaft seal
25. Impeller key
26. Impeller washer
27. Impeller nut
28. Impeller
29. Discharge casing
30. Suction cover
31. Hex head cap screw
32. Suction cover gasket
33. Hex nut and hex head cap screw
34. "O" ring
35. Packing flange
36. Lower bearing housing
- *37. Discharge casing sleeve bearing
38. Hex nut and washer
- 39A. Stud
- 39B. Hex head cap screw and washer
40. Packing housing
41. Dust cap
42. Hex nut and washer
43. Intermediate bearing housing
- *44. Intermediate sleeve bearing
45. Hex head cap screw
46. Stud
47. Hex nut and washer
48. Discharge pipe
49. Hex nut
50. "O" ring
51. Hex head cap screw
52. Discharge elbow
53. Grease fitting
54. Strainer assembly
55. Motor half coupling
56. Pump half coupling
57. Coupling flexible member
58. Set screw

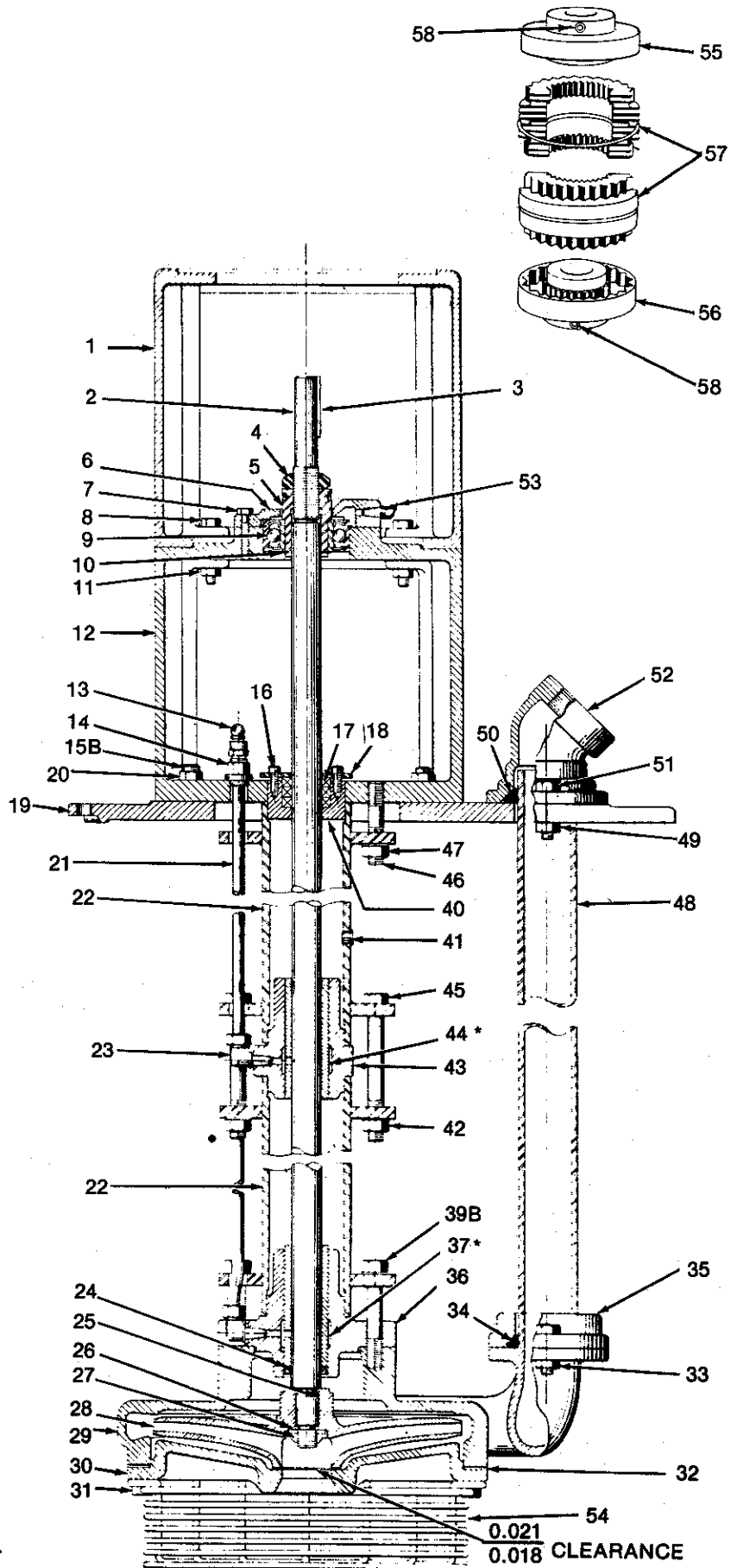

*Recommended spare parts for two years.

Figure 6. LH2A, LB3A and LB4A Sump Pump

- 22. Hanger pipe
- 41. Caplug plug
- 74. Upper shaft
- 75. Taper pins
- 76. Shaft coupling
- 77. Lower discharge pipe
- 78. Discharge elbow
- 79. Upper discharge pipe
- 80. Lower pump shaft

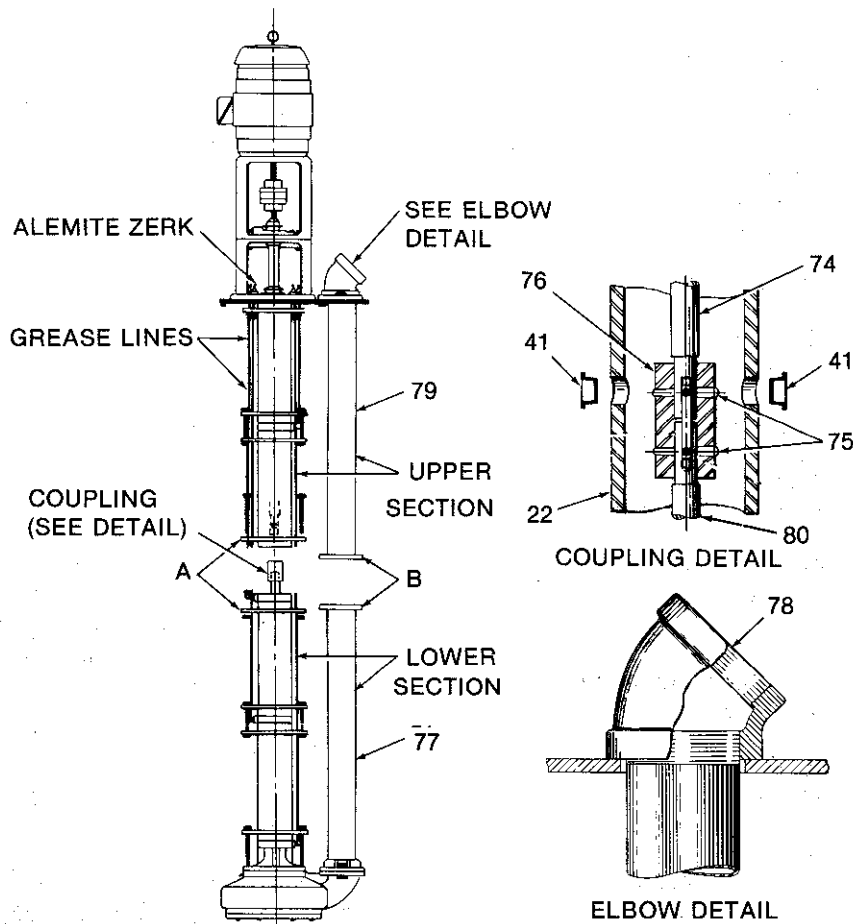

Figure 7. Two-Section Sump Pump

NOTE: On two section pump, discharge pipe is threaded to discharge elbow.

12. To remove discharge elbow, unscrew nuts (49) joining elbow and pump floor plate (19).

13. To remove intermediate bearing housing (43) unscrew nuts (42) joining hanger pipe assemblies and pull sections apart.

14. To remove bearing pedestal (12) from pump floor plate (19) unscrew nuts (20).

15. To remove ball bearing (9) from bearing adapter (12) remove snap ring (10) with snap ring pliers, or pry loose from its seat in bearing adapter with a screwdriver. Remove bearing by pressing it from the adapter.

16. To remove sleeve bearing (37 or 44) from bearing housing (43), or from lower bearing housing (36) (see figure (6)), use a drift and drive bearing from its housing.

CAUTION Refer motor to a repair shop authorized by the motor manufacturer for repairs. It is not recommended that user attempt to make repairs on this type motor under any circumstances. Attempt to repair unit by unauthorized personnel voids manufacturer's warranty.

WARNING Petroleum base cleaning solvents are flammable. Open flame or smoking by personnel in the vicinity of these solvents is extremely hazardous and must not be permitted. Disregard of this Warning can result in serious bodily harm and could be fatal.

CLEANING: Pump parts may be cleaned with petroleum base solvent if desired.

Metal parts (except motor) may be soaked in solvent if necessary.

Use a bristle brush (not metal or wire) to remove tightly adhering deposits.

Wipe the exterior of motor housing with a solvent-dampened cloth.

Blow parts dry with clean, dry, compressed air.

Clean ball bearings in the following manner:

1. Place bearings in wire basket - so there is space for cleaner to reach all parts.
2. Immerse in Stoddard solvent. Agitate basket until old grease is thoroughly loosened and can be flushed out.

- Place bearing on a screened surface.
- Using a spray gun with air filter and clean Stoddard solvent, flush each bearing until all grease and sludge is removed.

WARNING Never spin ball bearings. Spinning a dry ball bearing can cause damage. Spinning any ball bearing by an air blast can cause bearing to fly apart resulting in possible fatal injury.

- Blow solvent out of bearings with dry, filtered air.
- Lubricate bearings immediately after cleaning with light spindle oil and place them in a covered container.

INSPECTION: Inspect pump parts for cracks, dents, nicks, scratches or other damage affecting serviceability or sealing.

Test cleaned and oiled bearings by rotating slowly with the hands. If worn, rough, noisy, loose or flatted, replace with new. Check bearing end play to be 0.006 inch maximum for single row. Do not unwrap new bearings until ready to be installed.

REPAIR: Remove burrs, nicks or scratches from non-critical surfaces with a fine stone or crocus cloth.

When ordering replacement parts always furnish data stamped on nameplate attached to the pump. Give the figure number, index number and part name as shown on figures 5 through 7.

BEARING REPLACEMENT: Install sleeve bearings in the following manner:

NOTE: The same bearing is used at both the intermediate and the lower bearing housings for each specific model of the same shaft size. LB2A pumps have 3/4-inch shaft while all others have 1-inch shaft.

- Thoroughly clean bore of bearing housing, avoid using abrasives.

- Set sleeve bearing on shouldered arbor and press in housing bore perpendicular to support face.

- For LB3A, LB4A and LH2A sump pumps, align grease hole visually, or blow air through grease line opening in bearing housing to insure that grease lubrication hole in bearing is positioned within the channel of the bearing housing (see figure 8).

- Check fit of bearing to shaft and if binding occurs ream bearing tube 0.003 to 0.005 inch larger than the shaft OD.

- For type LB2A pump use a shouldered arbor to press bearing (19, figure 5) in approximately flush

with bearing housing (18) or discharge casing (23). Do not machine bearing bore.

ASSEMBLY: For type LB2A pump (see figure 6), reverse the disassembly procedure, observing the following:

- Replace all worn parts, order parts by part numbers, and give the pump serial number stamped on the nameplate.
- File off all burrs made on the machined surfaces.
- It is good practice to use new gaskets, particularly gaskets (32) and (35).
- Be sure machined tongue and groove registers are clean and smooth.
- Apply soap or oil at the ends of the discharge pipe when inserting it in the discharge ell and discharge casing. If new pipe is used, break corners with a file.

Setting and Adjusting the Impeller:

- With the stop nut (4) and the set screw (6) loose, position the impeller so that the bottom end rests on the suction casing (25).
- Tighten the stop nut (4) against the adapter (5) until the impeller (24) clears the suction casing (25) by 0.012 to 0.015 inch as shown in figure 5.
- After the stop nut (4) has been adjusted, tighten the set screw (6). Be sure the set screw is properly positioned in the milled slot provided in the shaft. The milled slot for the set screw is directly below the milled slot for the Woodruff key (3).
- Re-check the impeller clearance.
- Turn the shaft by hand to see if the impeller is rubbing.
- To raise the impeller, loosen the set screw (6) and tighten the stop nut (4). When positioned, retighten the set screw.

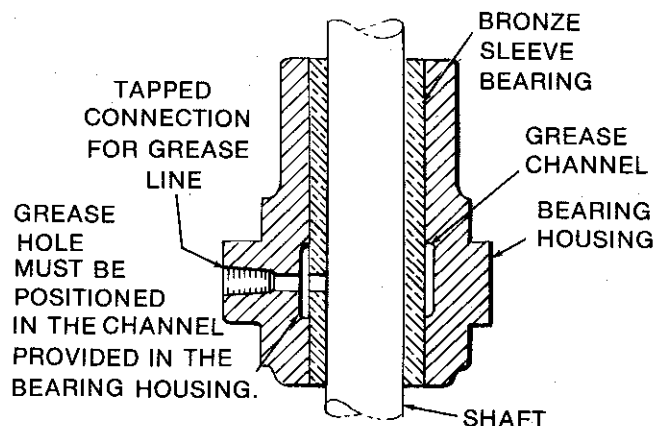

Figure 8. Installation of Sleeve Bearing for Types LB3A, LB4A and LH2A



Peerless Pump Company
LaBour
Taber

Peerless Pump Company
2005 Dr. Martin Luther King Jr. Street
Indianapolis, IN 46202
Phone: (317) 925-9661 • Fax: (317) 924-7388

7. To lower the impeller, loosen the set screw (6) and the stop nut (4) and lightly tap the shaft at the coupling until the shaft drops. When positioned, retighten the set screw.

Assemble the LB3A, LB4A and LH2A sump pumps as follows (see figure 6):

1. Press bearing (9) on adapter (5) by applying force ONLY to inner race and install snap ring (10). Be sure ring seats in groove all around.
2. Assemble hanger pipe (22), matching the marks applied during disassembly, together with grease lines (21) and associated parts that may have been removed.
3. If bearing pedestal (12) was removed, locate on floor plate (19) and attach nuts (20). Tighten securely.
4. Install new O-ring (50) in discharge ell (52), locate on floor plate and attach screws (51) and nuts (49). Tighten securely.
5. If not already done, round both ends of discharge pipe (48) with a file. Apply soap or light oil to both ends of pipe and insert one end in discharge ell with a twisting push. Slide packing flange (35) and a new O-ring (34) on the other end of discharge pipe.
6. Install discharge casing (29). Attach screws (39B) or nuts (38). Slide packing flange (35) against casing and attach screws and nuts (33). Tighten all securely.
7. Insert key (25) in shaft (2) slot and install impeller (28) on shaft. Using a hardwood block or bronze rod, tap the impeller to a firm seat on the shaft. Install washer (26) and nut (27) and tighten securely.
8. Install a new shaft seal (24), with lip pointing toward sleeve bearing (37), in lower bearing housing (36). Make sure seal is not cocked and seated all around in housing.

When the pump casing has been provided with a cutless rubber bearing, shaft seal (24) is not furnished and should not be used.

9. Apply a thin coat of light oil or grease over entire length of shaft and insert shaft through seal and bearings.

10. Install suction cover (30), strainer (54) when used and attach screws (31) tightening securely.

11. Install bearing adapter (5) on shaft and turn clockwise until bearing (9) seats in pedestal (12). Install bearing cap (6) and screws (7), tightening securely.

12. Adjust impeller clearance as follows:

a. Block shaft at pump coupling to keep shaft from turning.

b. With spanner wrench, turn bearing adapter (5) counterclockwise until impeller lightly touches suction cover (30). The shaft should be rotated during this adjustment in order to feel when impeller begins to rub.

c. When impeller rubs, turn bearing adapter (5) slowly clockwise until impeller is free. This method of adjustment will give approximate impeller clearance of 0.018 to 0.021 inch as illustrated in figure 6). Clearance may be checked with feeler gage.

d. When impeller clearance is correct, install and tighten nut (4). Manually rotate impeller to check that there is no rubbing.

13. Install new packing (17), packing plate (18) and screws (16).

14. Install coupling key (3), pump coupling half (56), flexible member (57) and temporarily secure with set screw (58).

15. Install motor as directed in Mounting Motor, under Installation.

16. Refer to one-section Pump Installation instructions at the beginning of this bulletin to reinstall the pump in the basin.

For Two-Section LH2A, LB3A and LB4A Pumps: Assemble upper and lower sections in the same manner as for the one-section pump applying steps 1 thru 11, and being sure to align match marks applied during disassembly. Refer at this time to the two-section Pump Installation instructions at the beginning of this bulletin to reinstall the pump in the basin. After such reinstallation, again continue with the one-section pump instruction steps 12 thru 15 to complete reassembly and adjustments.

Notice: Materials of construction, specifications, dimensions, design features, and application information, where shown in this bulletin, are subject to change and/or modification without notice by Peerless Pump at their option.