

SEALTRODE TERMINAL HOUSING ASSEMBLY



Peerless Pump Company
2005 Dr. Martin Luther King Jr. Street
Indianapolis, IN 46202
Phone: (317) 925-9661 • Fax: (317) 924-7388

IMPORTANT SAFETY PRECAUTIONS

Control assembly and the tools and lifting equipment used in installation are heavy and may easily cause personal injury if dropped or carelessly handled. The normal precautions and safety rules associated with the installation or repair of machinery, in regard to manual lifting, use of power equipment, and handling of tools, must be observed in the installation of this controller.

Petroleum-base cleaning solvents are flammable. Smoking by personnel, open flame, or other activity which could ignite vapors in the vicinity of these solvents is extremely hazardous and must not be permitted.

Do not work under a suspended object unless there is a positive support under it to stop its

fall in event of sling or hoist failure.

Before attempting examination, handling or repair, be certain that the electrical power supply is shut off. An electrical shock from contact with live wires or cords can be fatal.

Before opening the conduit box of an electric motor, a switch cover, starter or panel door, be certain that the power supply is shut off. An electrical shock from contact with live leads can be fatal.

Before attempting repairs to installation, disconnect power supply. Controls are automatic. This prevents accidental running of pump motor. Starting motor during repair activities could damage pump and may cause personal injury.

INTRODUCTION

UPON RECEIPT OF CONTROL EQUIPMENT: Check carefully to see that all of the equipment has been received. Report immediately any shortages or damages to the transportation company handling the shipment, noting the extent of the damage or shortage on the freight bill and bill of lading.

Do not leave the unit exposed to weather or construction hazards. The controller may become mechanically damaged. This controller is a well designed

and carefully manufactured unit. It should be given the same attention accorded to any precision machine.

The satisfactory operation of this controller depends to a large extent upon proper installation. These instructions cannot answer every question that may arise as each installation will be different. The installer and the operator of this equipment must use good judgement to adapt these procedures to the installation.

INSTALLATION

WARNING

Do not work under a suspended object unless there is a positive support under it to stop its fall in event of sling or hoist failure. Disregard of this warning could result in grave personal injury.

ELECTRODE HOUSING: If furnished in two or more sections, screw the 1½" pipe (Electrode Housing) together with couplings provided. Screw the bulb assembly (20) (21) (22) (23) to the bottom of the 1½" Electrode Housing. Be sure to use a good pipe thread compound to insure a water tight connection.

To protect and facilitate installation, roll the flexible bulb into a compact bundle about its vertical axis and

temporarily encircle the roll with tape to secure. Carefully lower the Electrode Housing assembly, bulb first, through the opening in the cover over the basin until the mounting flange rests on the basin cover. Remove tape.

MOUNTING FLANGE: The SEALTRODE® Series P Pump Controller is furnished with one of two styles of mounting flanges: standard for mounting on metal basin covers, and style F for concrete mounting, both illustrated on page 5.

The Mounting Flange (15) has been preset at the factory for the correct basin depth and should require no further adjustment. Refer to page 5 for factory settings.

TERMINAL HOUSING ASSEMBLY: For aid in installation the factory has pre-assembled the terminal housing (27) reducer tee (12) and compression coupling (13) together. This assembly also includes the suspension wires (18), electrodes (19) and fill-vent tee (5).

Remove tape from and straighten the electrode wires. Remove kinks if necessary. Make sure all wires are marked. Wire "A" is the longest, wire "B" is the next longest, etc.

Feed electrodes (19) and wires (18) into the Electrode Housing, being careful not to tangle or twist wires. Place terminal housing assembly on top of Electrode Housing (17) and press down on terminal housing assembly until pipe is inside of compression coupling (13). Hold the terminal housing in position and screw the cap on the compression coupling until the assembly is secured to the electrode housing (17).

VENT: Atmospheric venting is required for this unit to operate. In normal, non-explosive atmospheres, venting is accomplished via the small pierced hole in the metal closure installed in the side opening of the fill-vent tee. If the terminal housing is to be installed in an explosive atmosphere, pry the metal closure from the tee and discard. The exposed vent opening should be connected to uncontaminated air by means of pipe or tubing. The opening is threaded behind the closure to accommodate a 3/4" pipe fitting.

CAUTION

Never block, plug or close off vent openings. Inspect closure for presence of pierced hole and add if missing. This device will not function without venting.

FILLING FLEXIBLE BULB: Fill the basin with water to a level approximately 4" below the cap to which the bulb is attached. Remove the plug from the top of the fill-vent tee. Tee is located near the terminal housing. Pour in the electrolytic solution (a mixture of 3 1/2 quarts of distilled water and one (1) package of sodium bicarbonate.) Replace the top plug.

WARNING

Before attempting repairs to installation, disconnect the power supply. Controls are automatic. This prevents accidental running of pump motor. Starting motor during repair activities could damage pump and may cause personal injury.

WIRING: Remove the cover (1) from the terminal housing and install conduit from the housing to the control box. Use 14 AWG wire with 600 volts rated

insulation and 3/64 inch minimum insulation wall thickness to connect the letter coded wires to the indicated terminals in the control box. Be sure electric current is the same as that stamped on the control box nameplate. Wire per wiring diagram supplied with control panel. If diagram is lost or misplaced copies may be obtained from your local Peerless representative.

NOTE: When the SEALTRODE® Control Box is remotely located the distance from the SEALTRODE® in the pumping station to the control box or panel should not exceed 100 feet.

Two separate metallic conduits are required from the pumping station to the building housing the control, one for the SEALTRODE® wires and one for the wires between the motors and controls.

GENERAL: The installation of the controller is now completed and the level within the 1 1/2" Electrode Housing will faithfully duplicate the liquid level in the basin ... actuating the control as the liquid rises and falls and making and breaking contact with the electrodes.

HOW TO ADJUST ELECTRODE SETTING: The electrode elevations have been pre-set at the factory and no further adjustment should be necessary. Should it be desirable, however, to readjust the factory settings refer to page 5 and note the assembly arrangement for anchoring the wires within the terminal housing. Also refer to page 5 and note and select the proper letter coded wire to be adjusted.

To adjust electrode remove the terminal housing cover (1) and slowly loosen the compression fitting (8) just enough to be able to slide the selected suspension wire up or down as required. When adjustment has been made, re-tighten the compression fitting.

There is sufficient suspension wire coiled inside the terminal housing to permit each electrode to be lowered a maximum of one foot, with the exception of the lowest electrode, which is the pump cut-out electrode with suspension wire labeled "A". The low electrode wire marked "A" is already positioned near the bottom of the 1 1/2" Electrode Housing and should not be lowered further. This also applies to electrode wire mark A1 or A2.

BELOW GRADE MOUNTING: When installing below grade make electrical connections above grade. There are 48 inches of suspension wire furnished past the terminal housing for below grade mounting.

CAUTION

Do not allow the liquid level in the basin to submerge the terminal housing.

OPERATION

As the liquid level rises in the wet well, a hydrostatic pressure on the flexible bulb is exerted. The hydrostatic pressure tends to squeeze the bulb, causing a displacement of its liquid. The displaced liquid rises in the electrode housing toward the electrodes. The liquid level within the electrode housing will always be equal to the level of the liquid in which the controller is submerged, since the density of both liquids are equal. As the liquid within the electrode housing rises and falls, it makes and breaks electrical circuits with the electrodes, thereby actuating the pump starters through the controller relays.

CAUTION

This controller should not be used in liquids having a temperature exceeding 140°F. or less than 35°F.

MAINTENANCE

The SEALTRODE® Series P Controller, if properly installed, requires little or no maintenance. It has no moving parts, except for the control relays which should be inspected semi-annually for worn or pitted contactors.

It is recommended that the operation of the controller be observed for several complete operating cycles when making routine maintenance and inspection of the pump.

REFILLING FLEXIBLE BULB: The electrolytic solution within the control bulb should seldom, if ever, be replenished because of evaporation. However, should it become necessary to replenish the liquid within the bulb, proceed in the following manner:

1. Refer to installation print showing the setting of the electrodes.
2. Note the setting of the highest electrode and what circuit it controls.

WARNING

Before attempting repairs to installation, disconnect the power supply. Controls are automatic. This prevents accidental running of pump motor. Starting motor during repair activities could damage pump and may cause personal injury.

3. Disconnect all electrical devices (pump starters) which are not controlled by the highest electrode to prevent their operation during the process of refilling the bulb.
4. Fill the basin to the highest electrode setting and then slowly pour distilled water thru the tee. Fill the connection until the high electrode circuit operates. When the circuit operates, add an additional quart of water.
5. In the event that the bulb has been over-filled, and the pumps do not cut-off, remove and empty the bulb and refill ... as outlined on page 3 under the heading "Filling Flexible Bulb".

LOCATING TROUBLE

IF THE PUMP FAILS TO START:

1. Make sure sodium bicarbonate has been added to water.
2. Check the electrical service, making sure the current characteristics are the same as that stamped on the control box nameplate.
3. Check to see if the control wiring is in accordance with the wiring diagram supplied with controller.
4. Determine if the electrical power at the control box has been interrupted or disconnected.
5. Check set screw (14) and make certain it is tight.
6. Short circuit the pump start electrode terminals in the control box with a piece of insulated wire. This should be done by a qualified electrician. If the pump operates check the following:
 - a. Inspect the wiring from the terminals in the control box to the controller terminal housing making sure that all connections are clean and tight. Look for broken wires.
 - b. Check the wire connections at the electrodes to see if they are broken.
 - c. Check to see if the flexible bulb has been damaged. If the bulb is damaged, liquid from the basin may have entered the housing and coated the electrodes with grease or oil. Grease and oil will insulate the electrodes.
 - d. Check the bulb for loss of electrolytic solution.
 - e. Check the setting of the pump cut-in electrode. It may be set too high.
 - f. Check for proper open venting of housing.
7. If the pump fails to operate after short circuiting the electrode terminals in the control, check the following:
 - a. Check the ground wire, making sure that it is not broken and terminal connections are clean and tight.
 - b. Check the control box for burned out transformer or relay coils.
 - c. Check the relay contacts to see if they are corroded, worn or pitted.
8. If the pump fails to cut off check the following:
 - a. Check the wire connections and insulation in the terminal housing and control box, making sure they are not forming a short circuit by being grounded to the box or housing.
 - b. Check the electrodes, making sure they are properly shielded. An electrode not properly shielded may form a short circuit with the electrode housing.
 - c. Check the relay contacts in the control box to see if they are stuck.
 - d. Too much liquid in the flexible bulb. Excessive liquid in the bulb will keep the low pump cut-off electrode submerged and the pump cut-in relay will not open.

SEALTRODE® TERMINAL HOUSING ASSEMBLY

for Pilot and Duplex Combination

Series P

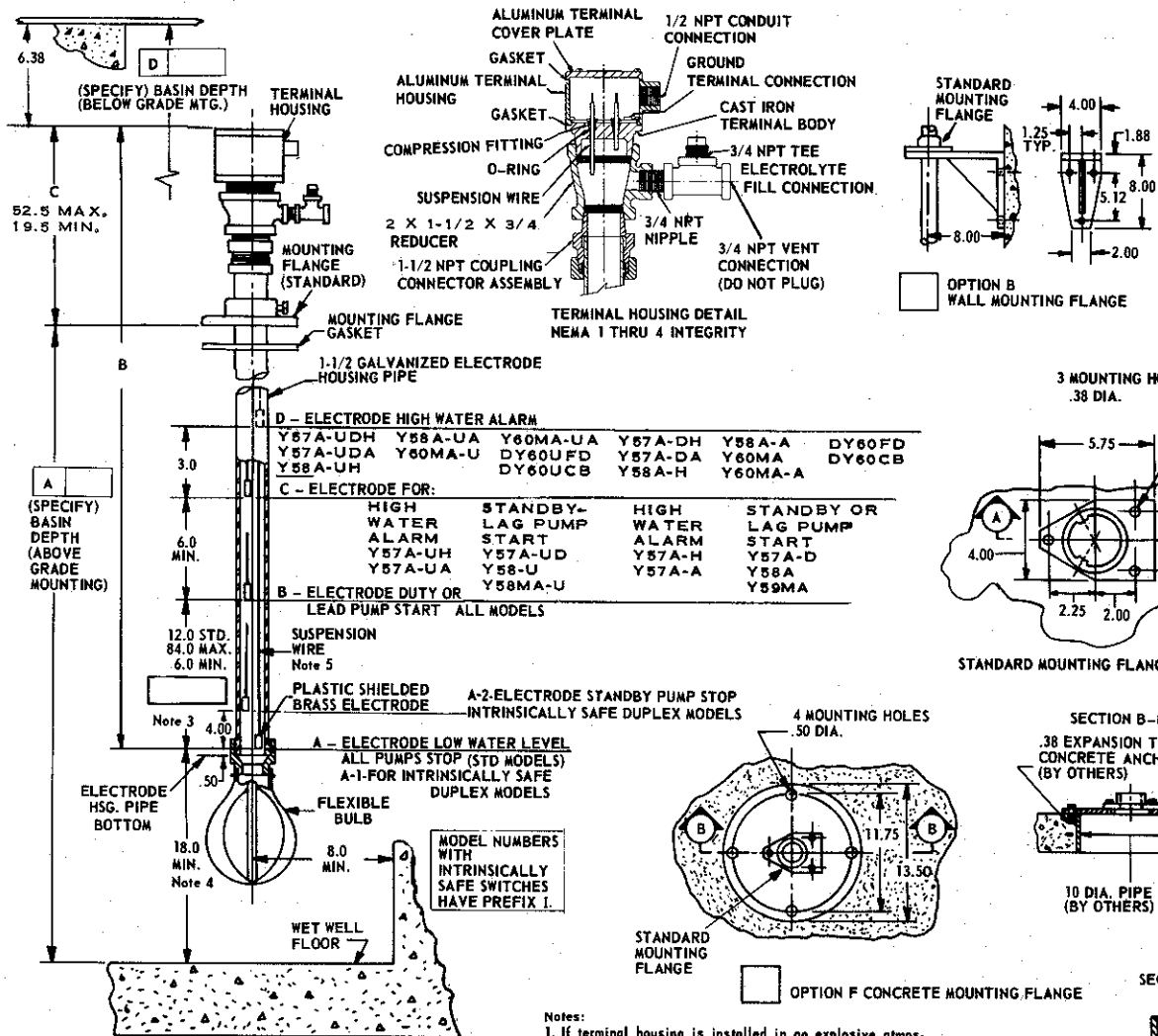

ABOVE GRADE MOUNTING DIMENSIONS (Standard Electrode Housing Pipe)						
Basin Depth	A		Option No.	B	C = B + 18.0 - Basin Depth	Weight Lbs.
	From Ft.-In.	To Ft.-In.				
3-0	5-9	8-3	53	70.5		20
6-0	8-9	11-3	83	106.5		30
9-0	11-9	14-3	113	142.5		40
12-0	14-9	17-3	143	178.5		50
15-0	17-9	20-3	173	214.5		60
18-0	20-9	23-3	203	250.5		70
21-0	23-9	26-3	233	286.5		80
24-0	26-9	29-3	263	322.5		90
27-0	29-9		293	358.5		100

BELOW GRADE MOUNTING DIMENSIONS (Special Length Electrode Housing Pipe)			
Basin Depth	B = Basin Depth - 24.38	C	Wt. Lbs.
	Minimum B Dim. is 43.62	13.62	7 Lbs. + 3 Lbs. per each foot Basin Depth

- Notes:
- If terminal housing is installed in an explosive atmosphere, pipe vent connection to uncontaminated air. (Piping by others.)
 - Below grade mounting SEALTRODE is furnished with 48 inches of wire past the terminal housing. This allows the electrical connection to be made outside of the basin. DO NOT allow the liquid level in the basin to submerge the terminal housing when installed below grade.
 - Specify when other than standard setting is required.
 - The actual height must be set to keep pump casing flooded. Refer to pump dimensional drawing for minimum water level exceeding 18 inches.
 - Suspension wires in terminal housing are labeled A, B, C, D. Refer to wiring diagram for proper connections in controller.
 - Electrolyte solution consists of a mixture of 1 ounce sodium bicarbonate and 3.5 quarts of distilled water. (1oz. package of sodium bicarbonate furnished with unit.)
 - When basin depth exceeds 20 feet housing pipe must be supported by wall brackets (by others).
 - All dimensions are in inches.
 - When the SEALTRODE is used with the intrinsically safe series 7 liquid level control installed in the pump control panel enclosure, the customer is to furnish a conduit seal (Crouse-Hinds EYS using CHICO A sealing compound) located within 18 inches of the control panel enclosure.

CUSTOMER _____ JOB NAME _____

P.O. NO. _____ ITEM NO. _____

S.O. NO. _____ CONTROLLER MODEL NO. _____ NO. OF ELECTRODES _____ WT. LBS. _____

ELECTRODE TERMINAL HSG. ENCLS. _____ TYPE ENCLS. _____ BASIN DEPTH _____ TYPE INSTALLATION _____

CERTIFIED FOR APPROVAL CONSTRUCTION BY _____ DATE _____

SUBJECT TO CHANGE
UNLESS CERTIFIED
FOR CONSTRUCTION

DT 4848247

UW SUBMERSIBLE PUMPS
Fusible Disconnect Switch DY60UFD
Circuit Breaker DY60UCB

TYPE L and TYPE VCS PUMPS
Fusible Disconnect Switch DY60FD
Circuit Breaker DY60CB

SERIES P DUPLEX COMBINATION SEALTRODE®
FLOATLESS CONTROLLER consists of:

- A. Electrode and terminal housing assembly including: galvanized steel electrode housing, NEMA 1 thru 4 terminal housing, 4 plastic shielded brass electrodes, 4 electrode conductor/suspension wires, rubber electrolyte storage bulb with adapter, electrolyte, adjustable basin cover mounting flange.
- B. Sealtrode duplex pump combination controller including:
- 2 - fusible disconnect switches or thermal magnetic trip circuit breakers
 - 2 - across-the-line magnetic motor starters with 3 coil overload protection for 3 phase or 1 coil overload protection for 1 phase
 - 2 - control circuit transformers with fused secondaries
 - 1 - set of Y60MA Sealtrode relays with motor operated electric alternator, for automatic alternation of lead-lag pumps, high water alarm circuit, for duplex submersible pump down operation.
 - 2 - sets of submersible motor thermal protection circuits
 - 2 - green pump running lights
 - 1 - audible/visible high water alarm mounted on enclosure with relay, silencing push button for audible alarm, red high water alarm light
 - 2 - submersible motor moisture detection circuits with relays, outer seal failure warning lights, continuity check circuits with lights and push buttons
 - 2 - hand-off-automatic selector switches in cover
 - 2 - capacitor circuit boards with motor capacitors mounted in enclosure for 1 phase motors only
- All mounted and pre-wired in NEMA 1 general purpose or NEMA 4 watertight dead front enclosure.

SERIES P DUPLEX COMBINATION SEALTRODE®
FLOATLESS CONTROLLER consists of:

- A. Electrode and terminal housing assembly including: galvanized steel electrode housing, NEMA 1 thru 4 terminal housing, 4 plastic shielded brass electrodes, *4 electrode conductor/suspension wires, rubber electrolyte storage bulb with adapter, electrolyte, adjustable basin cover mounting flange.
- B. Sealtrode duplex pump combination controller including:
- 2 - fusible disconnect switches or thermal magnetic trip circuit breakers
 - 2 - across-the-line magnetic motor starters with 3 coil overload protection for 3 phase or 1 coil overload protection for 1 phase
 - 2 - control circuit transformers with fused secondaries
 - 1 - set of Y60MA Sealtrode relays with motor operated electric alternator, for automatic alternation of lead-lag pumps, high water alarm circuit, for duplex down operation
 - 2 - green pump running lights
 - 1 - audible/visible high water alarm mounted on enclosure with relay, silencing push button for audible alarm, red high water alarm light
 - 2 - hand-off-automatic selector switches in cover
- All mounted and pre-wired in NEMA 1 general purpose enclosure, NEMA 4 watertight dead front enclosure or NEMA 7 Class 1, Division 1, Group A, B, C and D explosion proof enclosure with intrinsically safe series 7 liquid level controls (see note 3 page 7).
- * NEMA 7 controllers are furnished with an extra electrode for standby pump stop.

Series P Pilot Sealtrode® Floatless Pump Controller consists of:

A. Electrode and terminal housing assembly including: galvanized steel electrode housing, NEMA 1 through 4 terminal housing; plastic shielded brass electrodes, electrode conductor/suspension wires, rubber electrolyte storage bulb with adapter, electrolyte, adjustable basin cover mounting flange.

B. Sealtrode relay panel (for operation of starting equipment by others) with relays for down pump operation in NEMA 1 general purpose, NEMA 4 watertight, or NEMA Class 1, Division 1, Group A, B, C and D explosion proof enclosure with intrinsically safe series 7 liquid level controls. NEMA 7 not available with UW pumps

Sealtrode UW Pump includes sub-motor moisture detection relay circuit, including outer seal failure warning light and continuity check circuit with light and push button.

SPECIFIC SERIES P PILOT SEALTRODE® PUMP CONTROLLER DETAILS

Pump Model		Type of Installation	CONTROLLER FEATURES					
			No. of Electrodes See Note 2	Type of Alternation			High Water Alarm Contacts (Alarm Annunciator by Others)	High Water Alarm with Annunciator Silencing Relay and Push Button Red High Water Alarm Light Enclosure Mounted
				None	Manual with Transfer Switch	Automatic with Motor Driven Electric Alternator		
UW Pumps	VCS & L Pumps							
Y56A-U	Y56A	Simplex	2	X				
Y57A-UH	Y57A-H	Simplex	3	X			X	
Y57AU-A	Y57A-A	Simplex	3	X				X
Y57AU-D	Y57A-D	Duplex	3	X				
Y57AU-DH	Y57A-DH	Duplex	4	X			X	
Y57AU-DA	Y57A-DA	Duplex	4	X				X
Y58AU	Y58A	Duplex	3		X			
Y58AU-H	Y58A-H	Duplex	4		X		X	
Y58AU-A	Y58A-A	Duplex	4		X			X
Y59MAU	Y59MA	Duplex	3			X		
Y60MAU	Y60MA	Duplex	4			X	X	
Y60MAU-A	Y60MA-A	Duplex	4			X		X

Notes:

1. For hazardous locations the NEMA 7 pump control panel enclosures have been installed within intrinsically safe series 7 liquid level controls. These Sealtrode model numbers have prefix letter I. (IY60MA)
2. NEMA 7 duplex controllers are furnished with an extra electrode for standby pump stop.
3. Intrinsically safe series 7 liquid level controls installed in the pump control panel enclosure are approved by Factory Mutual for use in Class 1, Division 1, Group A, B, C and D hazardous atmospheres. Series 7 controls limit the current in the electrode to values considered safe. The pump control panel enclosure requires explosion proof integrity. However, the Sealtrode enclosure does not normally require explosion proof integrity.



Peerless Pump Company

P.O. Box 7026 • Indianapolis, IN 46207-7026
 Phone: (317) 925-9661 • Fax: (317) 924-7388

A member of the Sterling Fluid Systems Group.

Item	Description
* 1	Cover
* 2	Slotted Screw
* 3	Upper Gasket
4	3/4" Pipe Plug
5	3/4" Tee
6	3/4" Nipple
* 7	Ground Terminal
* 8	Compression Fitting
* 9	Phillips Head Screw
* 10	Lower Gasket
* 11	O-Ring
12	Reducer
13	Coupling Compression
14	Set Screw Sq. Hd.
15	Mounting Flange
16	Gasket Mtg. Flg.
17	Electrode Hsg.
18	Suspension Wires
19	Electrodes
20	Bulb Adapter
21	Hose Clamp
22	Band Protector
23	Bulb
* 24	Housing
* 25	Body
* 26	Vent Cap

(27) * These parts make up the Terminal Housing

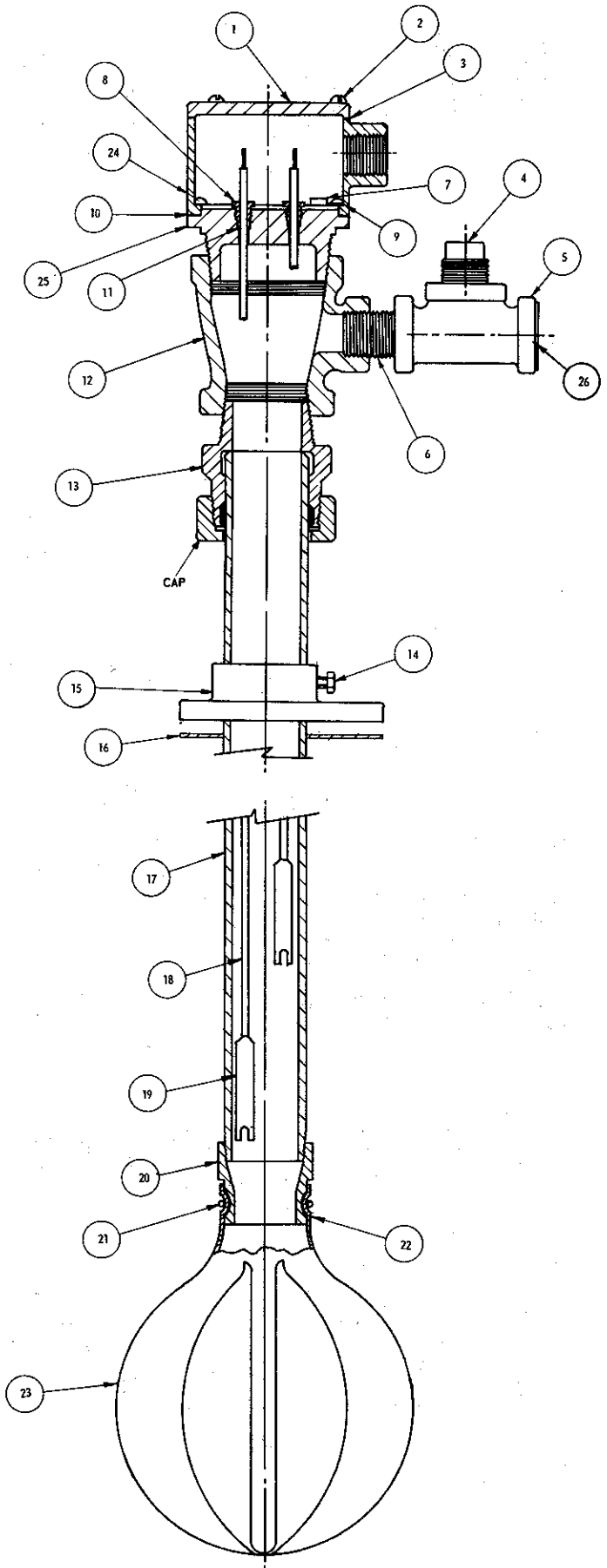

Peerless Pump Company
 2005 Dr. Martin Luther King Jr. Street
 Indianapolis, IN 46202
 Phone: (317) 925-9661 • Fax: (317) 924-7388

4848247 Rev. 8/78

PRINTED IN U. S. A.