

Service Instructions

Submersible Pumps with 12" and
Larger Submersible Motors

Pump No. _____

Invoice No. _____

P.O. No. _____

Item No. _____

Vertical Submersible Pumps

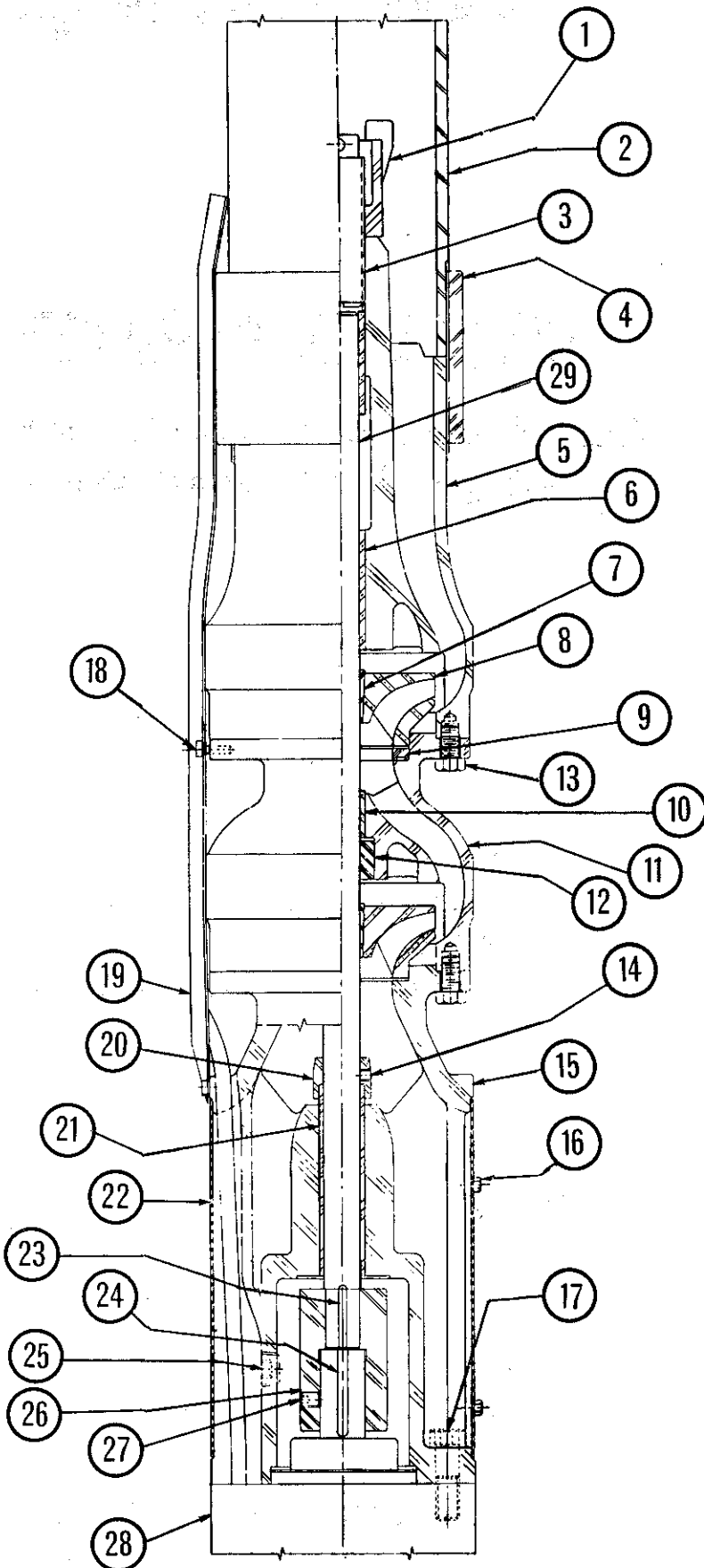

Item No.	Description
1	locknut
2	column
3	upthrust bearing
4	column coupling
5	top bowl
6	bearing
7	taper lock bushing
8	impeller
9	lateral seal ring
10	bearing
11	standard bowl
12	bushing
13	cap screws
14	set screws
15	interconnector
16	cap screws
17	cap screws
18	cap screws
19	cable guard
20	sand collar
21	bearing
22	interconnector screen
23	key
24	key
25	pipe plug
26	coupling
27	set screw
28	submersible motor
29	impeller shaft

Drawing No. 2618370

Installation and Operation Instructions

for Bowl Units with 12" and larger Submersible Motors

The Peerless submersible pumps are multi-stage vertical turbine pumps. Each stage consists of a bowl and an impeller.

The impeller shaft is directly connected to the motor shaft with a coupling. The motor is attached below the pump and takes the thrust of the pump on a tilting shoe thrust bearing. This motor is specifically designed for submerged operation and continued operation of this motor out of water will cause it to burn out.

Peerless submersible pumps are well constructed, and if installed and operated with reasonable care should give years of satisfactory service with a minimum of maintenance. Be sure to check the pump and motor for damage in shipment immediately after its receipt. A damaged shipping crate is an indication of mishandling, so a careful inspection should be made.

MOTOR:

The motor instruction sheet enclosed in the shipping crate should be referred to for proper motor care. Remember, the motor used on submersible pumps is not a standard electric motor and requires special and careful handling.

Peerless submersible pumps are furnished with one of two types of motors. One is water filled, the other dielectric oil filled. There is little difference in operating conditions or performance between the two motors.

KEEP THIS BULLETIN FOR FURTHER SERVICE AND OPERATION REFERENCE.

MOTOR CONTROL BOX:

Special motor control boxes are not normally furnished with three phase submersible motors. We recommend that the pump installer use a

standard motor control that has three leg protection if the local conditions so indicate. A quick-trip type control is strongly recommended. A variable overload or an ambient-compensating overload should be used if a wide range of ambient temperature is expected. If the control housing is not weatherproof it must be protected from extreme weather conditions.

CHECKING THE WELL:

Before any attempt is made to install the pump, the well should be carefully checked to determine that the casing is of the proper diameter, depth and straightness. If there is any doubt about the size or accuracy of the well, consult your pump dealer and, if necessary, have it carefully surveyed and plotted to determine that the pump can be installed properly, and will operate normally. Since the pump drop pipe can be curved, within limits, without being detrimental to pump operation, the well should be surveyed to find out in what direction and how sharply it curves throughout its length.

Wells for which the exact depth and diameter are not known, should be checked even if they are not crooked, because the lower strings of casing are frequently smaller in diameter than the upper ones.

If a well is crooked, surveying is important especially when the pump outside diameter is close to the well inside diameter.

Surveying involves lowering into the well, to a point below the pump setting, a checking tool which is the maximum diameter and length of the pump, together with a piece of drop pipe the same size as is to be used on the pump at least 50 feet long.

In a crooked well a submersible pump will work much better than a lineshaft pump because it has no lineshaft in the well causing excessive friction and wear.

DEVELOPING THE WELL:

Developing the well and freeing it from sand are part of the well driller's job and should be done with a test pump reserved for this purpose. However, if a test pump is not available and a new pump must be used, extreme care should be taken. Throttle the discharge at least until such time that the water clears from excessive sand. Even then, any and all precautions which might have been taken will not insure that the pump will not be badly sand cut during the process. Therefore, if at all possible, use a test pump to develop the well because the customer is solely responsible for any damage to the new pump caused by sand cutting.

AIR AND GAS IN THE WELL:

If air or gas is present in the water, the pump will not meet the performance requirements and, if either is present in excessive quantities, pumping may stop altogether. The presence of gas or air may cause vibration and damage. If it is known that gas or air is present, consult your dealer or the pump manufacturer for advice.

THE PUMP FOUNDATION:

Whenever possible, a substantial concrete foundation should be built around the well before the pump is installed. The top of the foundation should be established so that from 1" to 1½" of well casing projects above it and large enough so that a generous shoulder will extend all around the base of the surface plate. The foundation should slope outward and downward and sufficiently deep into the ground to provide the required thickness for strength as well as to secure a firm footing.

The thickness and ground area for the foundation will depend upon the firmness of the supporting earth around the well at any and all

times (considering rain or flood effects) and the weight of the complete pumping unit when full of water. Total load of foundation = dead weight of all parts + weight of water in column. These tables may be used for reference when figuring the size of the foundation.

A piece of 2" pipe set near one corner and not over 1½" above the top of the foundation and where it will clear the surface plate, will prove very convenient for placing a pipe extension to anchor the chain tongs when making up the column joints. The anchor pipe should extend a generous distance below the foundation to give rigidity and the top should be threaded and capped when not in use to prevent dirt from entering.

APPROX. WT. OF WATER IN 1 FT. OF COL.			
Nom. Pipe Size	Schedule	Wt. per Ft. of Pipe	Wt. of Water per Ft. of Pipe
3	40S	7.58	3.0
4	40S	10.79	5.0
5	40S	14.62	8.0
6	40S	18.97	12.0
8	30	24.7	20.0
10	30	34.24	23.0
12	30	43.77	48.0
14	30S	54.57	57.0
16	30S	62.58	76.0
18	30	82.06	97.0
20	30X	104.13	120.0
24	30X	125.49	177.0

PERMISSIBLE LOAD ON SOIL	
NATURE OF SOIL	LBS. PER SQ. FT.
Packed gravel	16,000
Compacted sand	8,000
Dry-thick clay bed	8,000
Moist thick clay bed	4,000
Dry sand	4,000
Soft, wet clay	2,000
Alluvial top soil	1,000

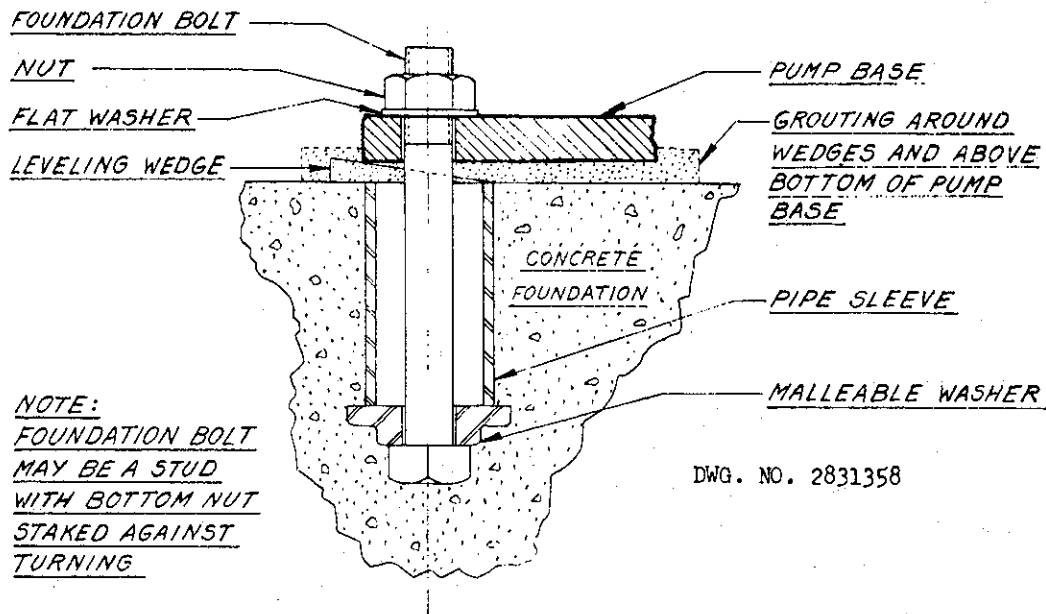

FOUNDATIONS OTHER THAN CONCRETE:

Structural foundations when properly constructed are very satisfactory for many types of installations as are a combination of structural and concrete. Foundations made up of structural members or wooden timbers spread on unstable soil are definitely not satisfactory.

WATER SUPPLY:

Any source of suitable water, free of solid material (e.g. sand) will be pumped satisfactorily. Seasonal and pumping drawdown should be ascertained to insure against the pump running dry, which may ruin both pump and motor. If this is not certain, the use of a high and low water level control or a water level indicator is highly recommended. For best results the pump should be located at least 10 feet below the lowest pumping level, and if possible above the water bearing strata. It is advisable to keep the bottom end of the motor at least 5 feet above the bottom of the well. A throttling valve should be installed in the discharge line to prevent over-pumping the well. If the motor must be set closer than 5 feet off bottom, or if there is any possibility of sand or mud covering the motor, a special motor skirt must be used to protect the motor from overheating damage. See your dealer for recommendations.

PUMP INSTALLATION:

SPECIAL TOOLS & EQUIPMENT REQUIRED FOR SUBMERSIBLE PUMP INSTALLATION.

- Voltammeter - for checking current.
- Sta-kon pliers or crimping tool - for securing cable connectors to the cable to the column.
- Banding Tool - for securing cable to the column.
- Band "Band it" - Stn. stl. band
- "Band it" buckle - for use with band.
- Rubber pads - to protect cable under "band it" band.
- Cable: 3 parallel conductors #1 or #1/0 AWG approximately 20 feet long - for checking of rotation of the unit before installation in the well.

After splicing of the drop cable to the motor is completed and checked for insulation, splice temporarily to the drop cable end, which sticks out of the hub of the reel 3 parallel conductors. Connect the other end of the 3 parallel conductors to the power supply. Check the rotation of the unit, mark drop cable leads for identification on final hook up. Disconnect the 3 conductors from power supply and drop cable. Proceed with installation.

Installation of a submersible pump is simple, but care in installation is important.

The performance may be limited or lowered by poor installation practice. It is therefore advisable to closely observe the following installation procedure.

1. Exercise caution in handling the pump:

The entire downthrust of the pump is carried on a special thrust bearing. This bearing can be broken if the pump is dropped or jarred, resulting in the pump becoming inoperative. The motor is enclosed in a metal tube. If this tube is damaged the motor may be affected and the performance of the pump substantially curtailed.

2. Prepare the motor for operation:

Follow the motor instruction sheet. Suggestions may seem trivial, but omitting them may shorten the motor life, and could void the warranty.

3. For 220 volt and 440 volt units splice the cable to the motor leads with Peerless waterproof cable connectors (PEERLESS PART #2615721). (For 2300 volt cable splicing see special instruction no. 2615721)

Taped Type Splice (PEERLESS PART #2615721)

Among the many effective methods of making waterproof splices, the following procedure has been found to be as satisfactory as any.

The following tapes are used:

1. "Bi-Seal" tape.

Supplier: Mitchell-Rand Insulation Co.
51 Murray Street
New York, New York 10001

Or: "Scotchfill" Electric Putty.

Supplier: Minnesota Mining & Mfg. Co.

2. "Scotch #33" electrical tape and "Scotch-kote"

Supplier: Minnesota Mining & Mfg. Co.

"Bi-Seal" tape is a self-bonding polyethylene tape which has excellent electrical properties and extremely low water vapor transmission.

"Scotchfill" electrical insulation putty is self-bonding and has good dielectric and excellent aging properties.

"Scotch #33" tape, although also a good insulating material, is used for mechanical protection due to its superior abrasion resistance.

"Scotch #22" tape is a heavier version of #33 and can be substituted but extra care in wrapping the splice is necessary.

In splicing, proceed as follows:

A. Snip outer jacket in two or three places and remove jacket with Sta-kon or similar pliers by peeling jacket back approximately one foot.

Remove cotton or any other tape from individual conductors in order to expose the insulation of each wire.

Utmost care must be exercised to remove all traces of tape from insulation of individual conductors, otherwise, thru capillary action, the water will enter the splice, thus shorting out the motor.

Strip the insulation of each conductor back far enough to allow conductor to extend half way thru the connector.

B. Apply "Bi-Seal" tape - first stretch tape 2 - 3 times its normal length. Start taping with a view of making a smooth contour across the length of the splice. Use normal tension in taping. Continue taping until the thickest part of the splice is about $1\frac{1}{2}$ times the conductor diameter. Use about a $1/2$ lap in taping. With each layer proceed beyond the start of the previous layer. Last layer should be at least $1\frac{1}{2}$ " beyond the end of the wire insulation.

When "Scotchfill" is used make a smooth contour over the connection by filling the voids and padding sharp edges of cable connectors. Extend the filling at least 1" over the end of the wire insulation.

- C. Applying four 1/2 lapped layers of "Scotch #33" tape going beyond the ends of the "Bi-Seal" tape.
- D. Apply one coat of "Scotchkote" over the tape going beyond the end of the tape over the cable jacket.

4. Test motor and connector as follows:

Check the winding resistances of the three-phase motor by touching the prongs of the meter to the cable leads of any two wires. The reading so obtained must be equal in all three legs. If otherwise, check with your dealer or motor manufacturer.

Also, check resistance of each lead to the water or water-container to determine a possible short to the water. The reading so obtained should be about 50,000,000 ohms (50 meg ohms) or more.

Voltage		
Nom	Min	Max
220	198	242
440	396	484

Above chart shows nominal, minimum and maximum voltages acceptable for safe operation of pump.

If power is available check rotation before lowering unit into the well.

A three-phase motor can run the pump in the wrong direction. If this is found to be the case, it can be corrected by changing any two of the power supply wire leads on the starting switch. NOTE: rotation should be counter-clockwise when viewed from the top bowl end of the pump.

The foundation should now be prepared for final setting of the pump unit. Remove the support blocks, and any other material from the top of the foundation and thoroughly clean it.

5. Lowering the pump into the well:

At no time clamp or hold the motor casing

with Stillson type wrench or chain tongs. The pump may be clamped but watch for motor leads going outside on the pump which are protected by a sheet-metal guard. Don't squeeze it.

Place timbers or equivalent support upon the foundation around the well casing for use as resting blocks for the elevator clamp.

Everything should now be in readiness for the final check of material and equipment before the actual installation of the pump is attempted. Securely fasten one elevator clamp on the top bowl. Attach the sling to the elevator clamps and pass the looped end over the hoist hook. While the helpers support the lower end of the pump, the unit is hoisted clear and into position over the well. It is then carefully lowered into the well until the elevator clamp rests upon the support timbers. The sling is removed for use in hoisting the following column pipes.

Extra care must be used when handling long pump units (6 foot or longer) because they can be easily damaged. It is suggested that such units remain fastened to the skids as they are received from the factory and lifted into a vertical position over the well before the skids are removed.

When making up any threaded joint be sure that the threads engage freely and square. Do not allow cross-threading, or assembly troubles will result. If cross-threading has accidentally started, be sure to break the joint, file and clean-up the threads before again making up the joint. If cross-threading damage is to extensive the offending part should be removed and replaced with a new piece. All threaded joints will make up easily if the threads are started properly. Use a good quality thread dope and make all joints TIGHT.

To lower the pump, just add successive lengths of random length pipe, playing out the cables and strapping them to the column every 20 feet. Place a rubber shield over the cable and fix them to the column. If airline is used,

fix it to the column at same time. Use "Band-it" clamps.

The following pictures show the banding procedure:

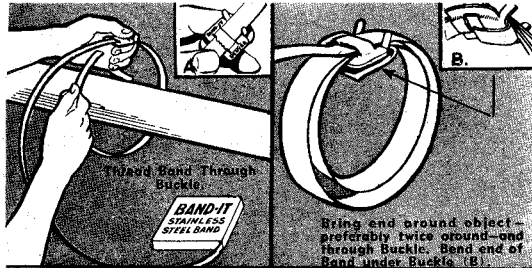

- 1 The Band may be precut from the bulk roll. To use, cut off about 12' of Band from bulk roll, hook one end on the buckle (a), and bring the other around the object to be banded and through the Buckle.
- 2 For best results, apply Band twice around. Double banding develops almost four times the grip of single banding.

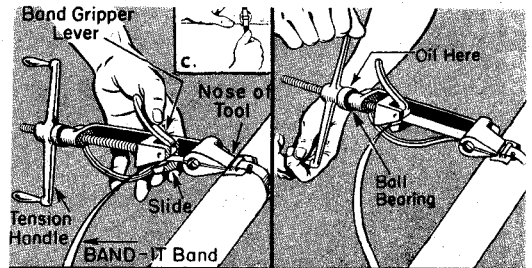

- 3 Draw Band snug (c). With thumb on Band Gripper Lever, apply tension with Tool.
- 4 Apply proper amount of tension (Band Gripper Lever locks itself under tension).

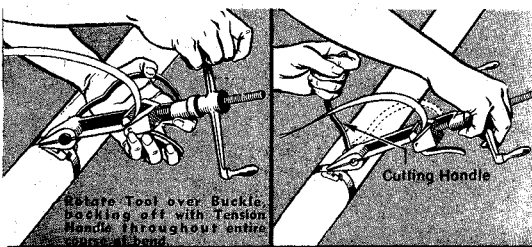

- 5 Failure to back off with Tension Handle throughout entire course of band may result in breaking of Band. There is no loss of tension, as Band released is used up in the bend.
- 6 Pull Cutting Handle to Cut the Band.

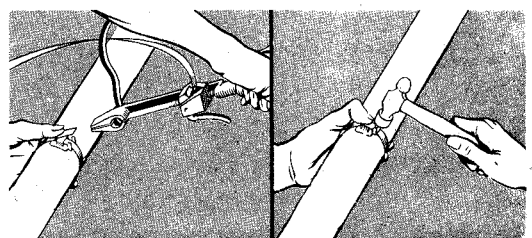

- 7 Remove Tool holding stub of Band down with thumb.
- 8 Clinch stub by hammering down Buckle ears, completing BAND IT Clamp.

For using "Band-it" clamp we need the following:

- "Band-it" stainless steel band, 3/8" wide
(One roll contains 100 feet of band)
- "Band-it" buckles, 3/8" wide
- Wire protector strips

As a pump column a commercial random length pipe with N. P. T. - 3/4" taper threads should be used. If Butt pipe threads (3/16" taper) are used the joints must be secured from unscrewing by means of set screws or pins in both ends of the pipe coupling.

When all of the column is assembled, and the surface plate is connected securely to the column, pass the cable through the entrance (if provided) in the surface plate. Lower the unit carefully on to the foundation. Line up the discharge and secure in place with mounting bolts. Utmost care must be exercised in lowering the unit not to damage cable by cutting or pinching against casing or casing flange.

If packed type cable seal is furnished it consists of:

1. 1 Packing Follower
2. 1 Ring of Packing
3. 1 Washer (on some cable sizes only).
4. 2 Nuts

2 types of CABLE SEAL:

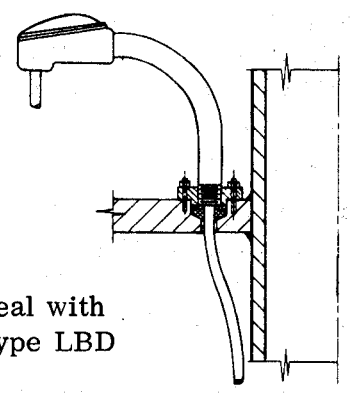

Packed type cable seal with conduit elbow and Type LBD conduit connection

Packed type cable seal

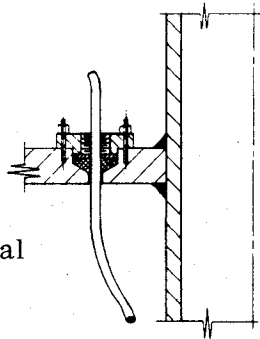

Assemble cable seal as follows:

1. Place packing around the cable. It should be preformed to fit in tapered section of cable entrance.
2. Place packing follower over the cable into place covering cable entrance.
3. Tighten nuts to compress packing around the cable thus forming a seal.

This type of cable seal is not designed to withstand pressure but it will form a sufficient seal to prevent foreign material from entering the well.

AIRLINE AND GAUGE INSTALLATION AND OPERATION INSTRUCTIONS

If the pump is equipped with a water level testing device, the airline, which is 1/4" O.D. copper tubing, should be tied at regular intervals as each component is lowered into the well. The airline is a copper tube, it usually goes in one or more pieces down to two feet from the screen upper edge.

On the top of the surface plate are assembled the water level gage, air valve and tee.

Accurate water level readings can be obtained by installing the gauge center at about the same height as the centerline of the discharge at the pump head, and any additional readings on the surface discharge head, in feet, can be added to the pumping level to give the total "water-to-water" pumping head.

Determine the exact vertical distance from the gauge center to the lower end of the airline and mark this length in feet and inches in the square provided on the gauge dial.

Adjust the movable gauge dial to correspond to the above determined length. Loosen the three screws on the face of the gauge and turn the dial until the graduation corresponding to the vertical height is opposite the hand pointer when the gauge is in an upright position. Check the dial after locking the screws.

Make sure that all joints of the air line, gauge fittings and air valve are air tight under pressure, and that the bottom end of the air line is not plugged.

"Standing" or "Static" water level readings are taken before starting the pump, or after a shutdown period long enough to allow the well water level conditions to reach normal. "Draw-down" and "Pumping Level" readings are taken after the pump has been operating against normal head for a period sufficient to pull down to the maximum point.

To obtain the above readings, pump air into the air line with a hand pump until the gauge ceases to rise, and note the gauge reading which is the distance from the gauge center to water level.

Keep a record of all readings and the date taken for a complete story on the well's performance due to seasonal changes.

An ordinary pressure gauge could be used instead of a water level gauge. In this case the pressure indicated by the gauge shall be multiplied by 2.31 to get the water height above the bottom end of airline pipe. The water depth in the well is airline length minus water height.

6. Wire the pump system:

Check the current at motor starter switch. Use snap-on voltammeter. Measure current in each line without throttling of the flow, after the pump is started. Readings obtained should be within 15% of the name plate rated full load current. Using same instrument check the voltage in each line. The readings should be within 10% of name plate rated voltage. A cable selection is an important factor. If improper cable is used the voltage drop may exceed the limits and serious damage may occur in the motor.

See your dealer for cable recommendations when in doubt.

Outside lines over 50 feet in length shall be protected by lightning arresters.

Voltage		
Nom	Min	Max
220	198	242
440	396	484

CHECK THE INSULATION

7. Throttle valve setting:

When first starting the pump in a well it is advisable to pay attention to the quantity of water the well can deliver to the pump and the amount of water the pump is capable of delivering to the system. The danger point is if the pump will carry off water faster than it flows into the well. If this occurs the supply of water in the well will be depleted before a pumping cycle is completed, causing the pump to run dry. In order to prevent this from occurring the following procedure should be followed:

When the pump is first put into operation the system has no water pressure, and therefore, the pump will deliver its maximum capacity until such pressure is developed. This sudden rush of water in the well may loosen sand, carry it into the water lubricated bearings of the motor and the pump and thereby wreck the pump, or at least limit its life. It is therefore recommended that a throttling valve be installed in the pump discharge. This valve should be opened just enough to permit a minimum flow of water when the pump is first started. Determine the water level in the well with the pump not running, start the pump and when the system is up to capacity, again determine the water level in the well. This change in water level is called the drawdown. If there is no appreciable change in the water level in the well, the valve may be opened more. The maximum permissible flow will be reached when the water level is drawn down to a certain level and that level is maintained until the pump again stops. With that valve setting the amount of water taken out of the well equals the amount of water flowing into the well. Seasonal changes

in well capacities should also be taken into account, or water level controls installed.

DISASSEMBLY OF BOWL UNIT

The bowl units used in submersible pumps are designed so that emergency repairs can be made in the field.

The special tools on page 11 are necessary to disassemble and reassemble submersible bowl unit.

1. The unit must be placed horizontally. Use 2 supports for the motor, and as many supports as necessary under the bowl unit to prevent bending.
 2. Remove cable guard and interconnector screen.
 3. Remove cap screws between motor and suction interconnector. Slide the motor back until it is separated from bowl unit.
 4. Remove lock nut from upthrust bearing. Remove upthrust bearing from top bowl.
 5. Remove cap screws in flange of suction interconnector and remove interconnector.
- Note: Screw type bowls may be removed by use of chain tongs but only after removal of locking set screw or pin in each bowl joint. Screw type bowls have right hand threads.
6. Loosen set screw in sand collar and slip off collar.

Caution: Check the impeller shaft for scribe mark. If original scribe mark does not appear on impeller shaft in the same plane as the lower face of the impeller skirt, scribe the shaft at this point. It is important that impellers be mounted in the same position on the shaft as in the original factory assembly.

7. Tap out split-tapered impeller lock with beater. Remove impeller from bottom of shaft.

Caution: Mark impellers in the sequence of their disassembly. Each impeller must be reassembled on the shaft in the same location as in the original factory assembly. Also, match each impeller and its impeller lock.

8. Spread split-tapered impeller lock with screw driver and slide it off bottom of shaft.

Note: The above procedure is repeated for each bowl in the assembly.

The bowl assembly is now ready for inspection of parts. See section titled "What to Look For" on page 12 and Trouble Chart on page 14.

SPECIAL TOOLS

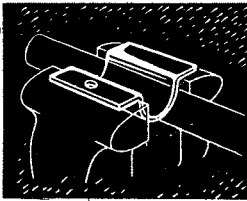

FIG. 1

SHAFT HOLDER. To protect shaft from scratches in vise.

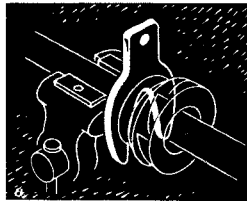

FIG. 2

FROG. For locating impeller on shaft.

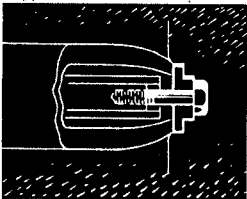

FIG. 3

TIE DOWN BOLT. To draw impellers down onto bowl seat.

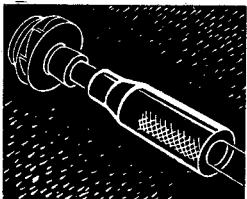

FIG. 4

BEATER*. For driving split-tapered impeller lock into impeller.

REASSEMBLY OF BOWL UNIT

1. Place impeller shaft in vise, using copper shaft holder (Figure 1) to protect the shaft. Recheck the shaft for freedom from nicks and scratches. Do not use a crooked shaft. Remove with a file all burrs and scratches. If shaft is satisfactory, check for scribe mark that locates the bottom impeller.
2. Place frog (Figure 2 special tools) on shaft and position the shaft in the vise so that scribe mark lines up with the surface of the frog, facing the top of the shaft.

3. Place the first impeller, removed in disassembly, on the shaft from the top and slide it into contact with the face of the frog.

Caution: In some bowl assemblies impeller hubs are stamped with an "H". When so stamped, mount alternate impellers with "H" marks in opposition.

4. Spread the split-tapered impeller lock with a screw driver or wedge inserted in the shaft and into the bore of the impeller. Remove the screw driver and clean off any burrs left by the screw driver with a file. Pound the bushing into place with the beater (Figure 4 special tools).
5. Remove the shaft from the vise and lay on rails for assembly of remaining parts. Next, slip the sand collar over the bottom of the shaft, but do not push it up to the impeller hub. Bring the suction interconnector into place against the impeller skirt allowing it to position the loose sand collar. Then move the sand collar about 1/16" toward the impeller hub and tighten the set screw.
6. Bring the suction interconnector up on the shaft until the impeller skirt is seated in the impeller seat on the interconnector. Paint the upper face of the interconnector flange or threads on screw type bowls with thread joint compound.
7. Place the first bowl on the shaft from the top. Move the bowl into position to fasten bowl flange cap screws into holes in suction interconnector flange and line up match marks. Bolt into place. Tighten only three or four bolts as each bowl is assembled to facilitate disassembly if that becomes necessary.
8. Check the shaft for lateral by the following method: Push the shaft toward the bottom of the pump as far as it will go. Scribe a mark on the shaft at the point where it enters the bowl hub. Then pull the shaft in the opposite direction as far as it will go. The distance from the top of the bowl

hub to the scribed mark on the shaft should be approximately 3/8". Be sure that shaft is free to rotate in the bowl. Check for free shaft and lateral after each bowl is assembled.

9. Before placing the next impeller on the shaft, pull the impeller already assembled down to the bottom seat by screwing tie down bolt (Figure 3) into end of shaft.

Note: The above procedure is repeated for each standard bowl in the assembly.

10. If motor-pump coupling has been removed from motor shaft, place the key in the key way of motor shaft. Slide motor-pump coupling on to the motor shaft as far as the upper edge of recess into motor-pump coupling. Tighten the set screw to lock the key and coupling on the motor shaft. Remove plug from inspection hole in suction interconnector coupling area. Set the impeller shaft key in the key way.

Slide the motor with motor-pump coupling over the impeller shaft guide carefully until it registers, line up mounting holes and fasten motor to the interconnector

with cap screws. Push the impeller shaft firmly against the motor shaft and check the impeller setting off bottom. It must be 1/8" to 1/4" off the impeller seat into suction interconnector. Replace the plug to cover the inspection hole.

11. Reassemble top bowl as follows: (a) Place on shaft the top bowl impeller and impeller lock as described above. (b) Slip top bowl over the shaft and position to fasten flange cap screws into holes in standard bowl flange. Bolt into place.
12. Assembling of upthrust bearing. Screw upthrust bearing into top bowl then install locknut onto upthrust bearing. See paragraph 14 for final setting of this assembly.
12. Assemble screen to the interconnector. Assemble the cable guard on the unit. Exercise utmost care not to damage the motor cable.
14. Setting of upthrust bearing. After the unit is raised in vertical position screw in the upthrust bearing until it butts against the impeller shaft then back up exactly 1/16" and tighten the locknut against the top bowl hub to secure the upthrust bearing in position.

WHAT TO LOOK FOR

TROUBLE SOURCES	PROBABLE CAUSE	REMEDY
Crooked shaft	Bent in installation.	Replace shaft. Check bushings.
Uneven wear on bearings.	Misalignment on shaft.	Replace bearings and straighten or replace shaft.
Wear on bearings.	Abrasive action.	Replace bearings.
Lateral seal ring wear.	Abrasive action.	Replace seal rings.
Wear on side seal and impeller skirt.	Abrasive action.	Apply wear rings to skirt and side seal if damage to bowl and impeller is not too great.
Wear on bowl vanes and outside wall.	Abrasive action.	Replace bowls if wear is excessive.
Wear on impeller vanes and shroud.	Abrasive action.	Replace impellers if wear is excessive.

WEAR RING APPLICATIONS

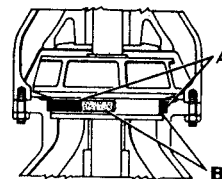

- A - Wear rings pressed into bowl seat.
- B - Wear ring pressed onto impeller skirt.

Wear rings should be made of bronze although cast iron or steel can be used if this material is not available.

When ordering parts direct, give the complete data listed on the nameplate, plus the item number listed in the parts list on the price book and a description of the part. If in doubt, see your dealer for the proper part description and number.

If **THREADED BOWLS** or **BUTT COLUMN** are used, the joints must be secured against unscrewing by means of set screws as shown below:

DRILLING NOTE: #7 (.201) drill 1/2 deep, 1/4-20UNC x 3/8 deep for Type I only. For Types II, III and IV drill & tap thru.

USE: Screw-set, headless, hexagonal socket, 1/4-20UNC x 3/8 LG. #2610680 DSCR 5.221

Type I

Installation on threaded bowl units. "A" dim. for 4" bowls = 5/6 "A" dim. for 6" & 7" bowls = 1/2 Drill & tap after assembly.

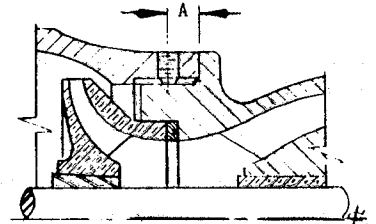

Type I

Type II

Installation of column adapter: Butt pipe coupling only. Drill & tap before assembly on top bowl or column pipe.

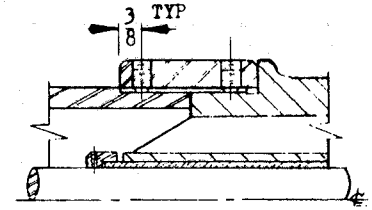

Type II

Type III

Installation of column adapter for butt pipe. Drill & tap before assembling on top bowl or column pipe.

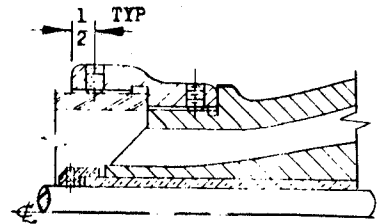

Type III

Type IV

Installation on 4LO & 4LD top bowls for 2 1/2" column & 6LB disch. manif. for 3" column. Drill & tap before assembling with column pipe.

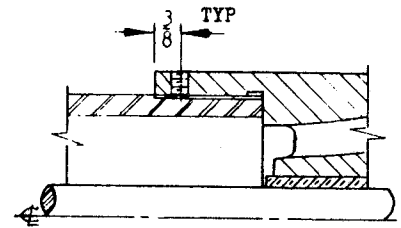

Type IV

Dwg. No. 2619647

CONDITION	CAUSE	REMEDY
Not enough water and pressure	<p>Low voltage</p> <p>Low water level in well</p> <p>Clogged suction screen</p> <p>Pump setting too deep</p>	<p>Increase size of power cable (see cable selection chart), check with power company.</p> <p>Lower pump into well if well depth permits. Throttle down pump discharge to compensate well drawdown. If well drawdown is inconsistent, installation of low level controls may be required.</p> <p>Valve in pump does not permit back-flushing. Clean screen.</p> <p>Check performance chart and compare to pump setting.</p>
No water (pump running)	<p>Check-Valve stuck</p> <p>Clogged suction screen</p> <p>Pump air locked</p> <p>Pump setting too deep</p>	<p>Check if check valve is correctly installed (arrow must point in direction of flow). Free check valve and clean seat.</p> <p>Valve in pump does not permit back-flushing. Clean screen.</p> <p>Free valve in pump discharge. Check if check valve is correctly installed and free. If well is gaseous remove valve at pump and install one riser pipe length above pump.</p> <p>Check performance chart and compare to pump setting.</p>
Pump not running	<p>Fuses burned out</p> <p>Switch point dirty</p> <p>Broken circuit</p>	<p>Check current specification of motor. Low voltage - check power company. Replace fuses.</p> <p>Clean or replace points in switch. Check if switch is rated for service.</p> <p>Make continuity check with Ohmmeter. If break is in cable or connector, repair splice or splice cable with Peerless waterproof connectors.</p>



Peerless Pump Company
205 Dr. Martin Luther King Jr. Street
Indianapolis, IN 46202
Phone: (317) 925-9661 • Fax: (317) 924-7388