

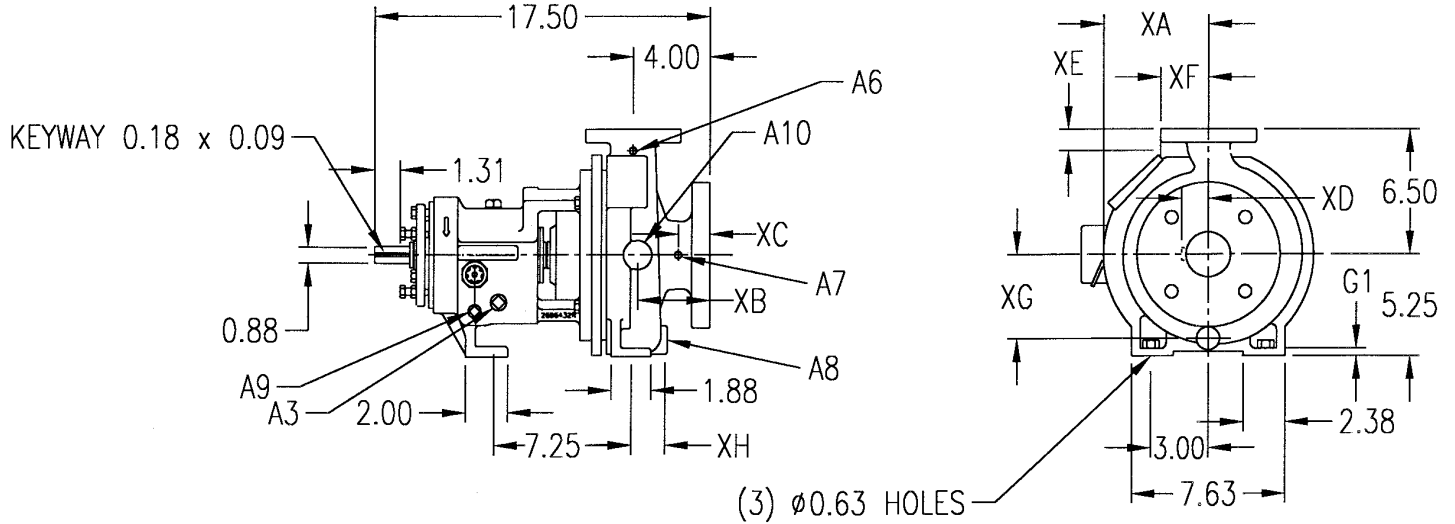

Pump Dimensions



A3	A6	A7	A8 ①	A9	A10
<input checked="" type="checkbox"/> COOLING CONN STD., 1/2 NPT & 1 NPT	DISCH GAUGE TAP, 1/4 NPT	SUCT GAUGE TAP, 1/4 NPT	CASING DRAIN, 1/2NPT	OIL DRAIN, 3/8 NPT	BY-PASS CONN., 1/4 NPT

<input checked="" type="checkbox"/>	Pump Size	Suction Size	Discharge Size	G1	XA	XB	XD	XE	XF	XG	XH	Wt Lb	Wt Kg
	8196 1X1.5-6 STP	1.5	1	0.50	4.00	3.63	1.88	1.56	0.94	3.69	1.50	84	38
	8196 1X1.5-6LF STP	1.5	1	0.50	4.00	3.63	1.88	1.56	0.94	3.69	1.50	84	38
	8196 1.5X3-6 STP	3	1.5	0.50	4.00	3.63	2.00	1.56	1.25	3.94	1.75	92	42
	8196 2X3-6 STP	3	2	0.50	4.06	3.50	2.25	1.50	1.50	4.25	1.88	98	44
	8196 1X1.5-8 STP	1.5	1	0.44	4.94	3.75	1.50	0.69	2.00	4.31	1.50	100	45
	8196 1X1.5-8LF STP	1.5	1	0.44	4.94	3.75	1.50	0.69	2.00	4.31	1.50	100	45
	8196 1.5X3-8 STP	3	1.5	0.44	5.00	3.75	2.00	0.69	2.50	4.38	1.81	108	49

<input checked="" type="checkbox"/>	Suction & Discharge Flange ANSI Lb Rating and Type (Select One)			
	150 Flat Face	150 Raised Face	300 Flat Face ②	300 Raised Face ②

Notes - Only items marked will be furnished All dimensions are in inches

① Standard on to Ductile Iron and 316 Stainless Steel construction

② Not applicable to Ductile Iron construction

Customer _____ Purchase Order No. _____ Service _____
 Pump Size _____ Material _____ Item _____
 Total Head Feet _____ GPM _____ Rpm _____
 Serial No. _____ Marks _____

Date _____ Signed _____

Certified for Approval Construction

**PROCESS PUMPS SINGLE STAGE END
 SUCTION
 ANSI Standard Dimensions
 Series 8196 - STP Frame**



Frame/Sealing Options

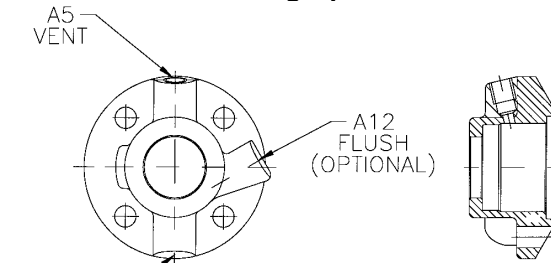

STP Gland Detail

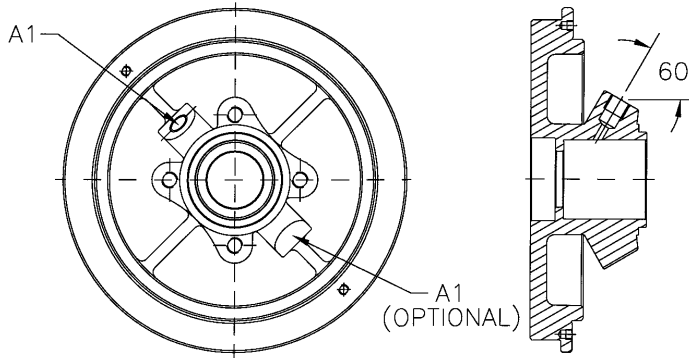

STP Stuffing Box Detail

Number	Size	Quantity	Purpose	Furnished	
				Yes	No
A1	¼ NPT	1	Lantern Ring Sealing	✓	
A1 (Optional)	¼ NPT	1	Lantern Ring Drain		
A5	¼ NPT	1	Vent Connection for Mechanical Seal	✓	
A5 (Optional)	¼ NPT	1	Drain Connection for Mechanical Seal		
A12 (Optional)	¼ NPT	1	Flush Connection for Mechanical Seal		

Pump Options (Select One in Each Group)	
Stuffing Box	Standard
	Taper Bore
	Large Bore
Bearing Lubrication	Oil
	Oil Mist
	Greased
	Greased for Life
Shaft	Sleeved
	Non-Sleeved
Box Cover Sealing	Packing Gland
	Mechanical Seal with Flush Gland
	Mechanical Seal with Vent and Drain Gland
	Less Gland

Customer _____ Purchase Order No. _____ Service _____
 Pump Size _____ Material _____ Item _____
 Total Head Feet _____ GPM _____ Rpm _____
 Serial No. _____ Marks _____
 Date _____ Signed _____

Certified for Approval Construction



Pump Dimensions

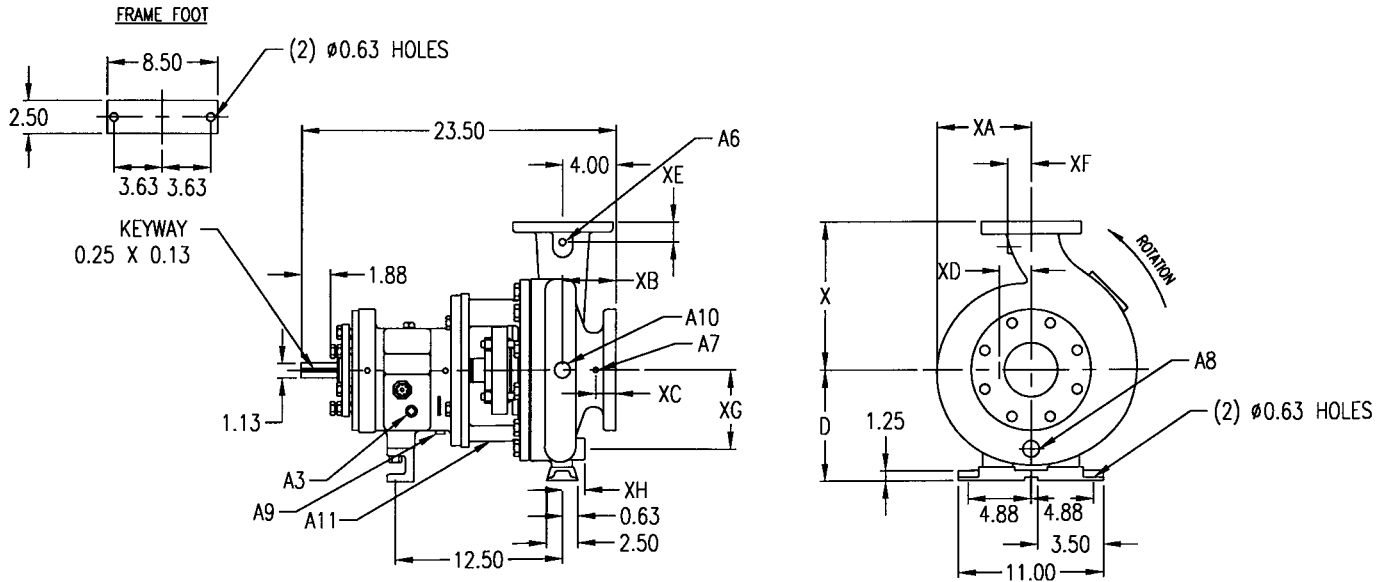

A3	A6	A7	A8 ①	A9	A10
✓ COOLING CONN STD., 1/2 NPT & 1 NPT	DISCH GAUGE TAP, 3/8 NPT	SUCT GAUGE TAP, 3/8 NPT	CASING DRAIN, 1/2 NPT	OIL DRAIN, 3/8 NPT	BY-PASS CONN., 1/2 NPT

A11
✓ 1 NPT ADAPTER DRAIN, STD

✓	Pump Size	Suction Size	Discharge Size	D	X	XA	XB	XC	XD	XE	XF	XG	XH	Wt Lb	Wt Kg
	8196 2X3-6 MTP	3	2	8.25	8.25	4.50	3.38	1.50	2.00	1.50	1.50	3.88	1.25	215	98
	8196 2X3-8 MTP	3	2	8.25	9.50	5.88	3.81	1.63	2.00	1.50	1.50	4.63	1.44	235	107
	8196 3X4-8 MTP	4	3	8.25	11.00	5.88	3.69	1.63	2.63	1.69	2.06	5.13	1.81	255	116
	8196 3X4-8G MTP	4	3	8.25	11.00	6.13	3.38	1.38	2.75	1.88	2.13	5.88	2.38	255	116
	8196 1X2-10 MTP	2	1	8.25	8.50	6.00	4.13	1.63	1.75	1.25	1.00	5.38	1.00	255	116
	8196 1.5X3-10 MTP	3	1.5	8.25	8.50	6.75	4.25	1.63	2.38	1.31	1.00	5.31	0.94	255	116
	8196 2X3-10 MTP	3	2	8.25	9.50	6.75	4.13	1.63	2.38	1.63	1.31	5.56	1.13	265	120
	8196 3X4-10 MTP	4	3	8.25	11.00	6.75	4.00	1.63	2.63	1.88	1.75	5.88	1.50	300	136
	8196 4X6-10 MTP	6	4	10.00	13.50	6.88	3.56	②	②	2.13	2.44	7.25	2.50	340	155

✓	Suction & Discharge Flange ANSI Lb Rating and Type (Select One)			
	150 Flat Face	150 Raised Face	300 Flat Face ②	300 Raised Face ②

Notes - Only items marked will be furnished All dimensions are in inches

① Standard on to Ductile Iron and 316 Stainless Steel construction

② Not applicable to Ductile Iron construction

Customer _____ Purchase Order No. _____ Service _____
 Pump Size _____ Material _____ Item _____
 Total Head Feet _____ GPM _____ Rpm _____
 Serial No. _____ Marks _____
 Date _____ Signed _____

Certified for Approval Construction

Drawing Number

4853898

PROCESS PUMPS SINGLE STAGE END SUCTION ANSI
Standard Dimensions
Series 8196 -6, 8, 10 Inch MTP
Frame/Sealing Options

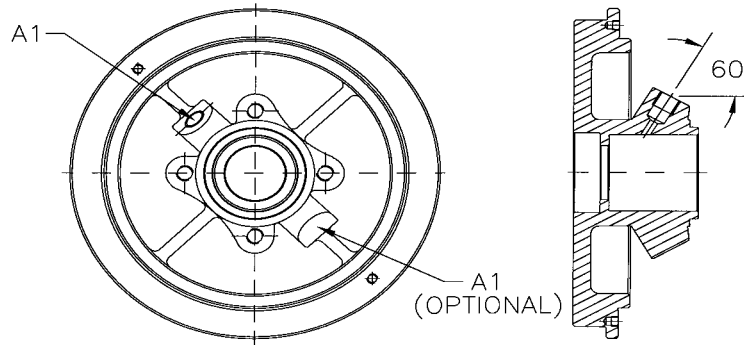
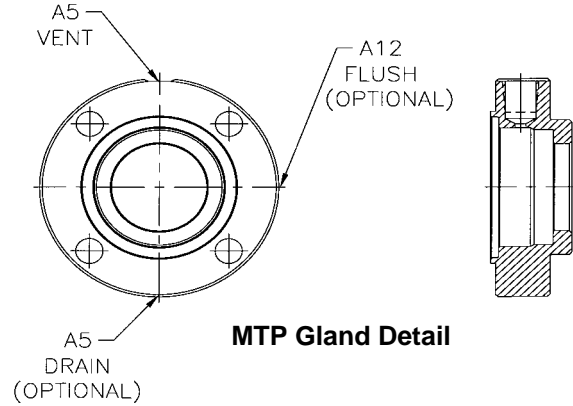

Number	Size	Quantity	Purpose	Furnished	
				Yes	No
A1	3/8 NPT	1	Lantern Ring Sealing	✓	
A1 (Optional)	3/8 NPT	1	Lantern Ring Drain		
A5	1/2 NPT	1	Vent Connection for Mechanical Seal	✓	
A5 (Optional)	1/2 NPT	1	Drain Connection for Mechanical Seal		
A12 (Optional)	1/2 NPT	1	Flush Connection for Mechanical Seal		

Pump Options (Select One in Each Group)	
Stuffing Box	Standard
	Taper Bore
	Large Bore
Bearing Lubrication	Oil
	Oil Mist
	Greased
	Greased for Life
Shaft	Sleeved
	Non-Sleeved
Box Cover Sealing	Packing Gland
	Mechanical Seal with Flush Gland
	Mechanical Seal with Vent and Drain Gland
	Less Gland

Customer _____ Purchase Order No. _____ Service _____
 Pump Size _____ Material _____ Item _____
 Total Head Feet _____ GPM _____ Rpm _____
 Serial No. _____ Marks _____
 Date _____ Signed _____

Certified for Approval Construction



Pump Dimensions

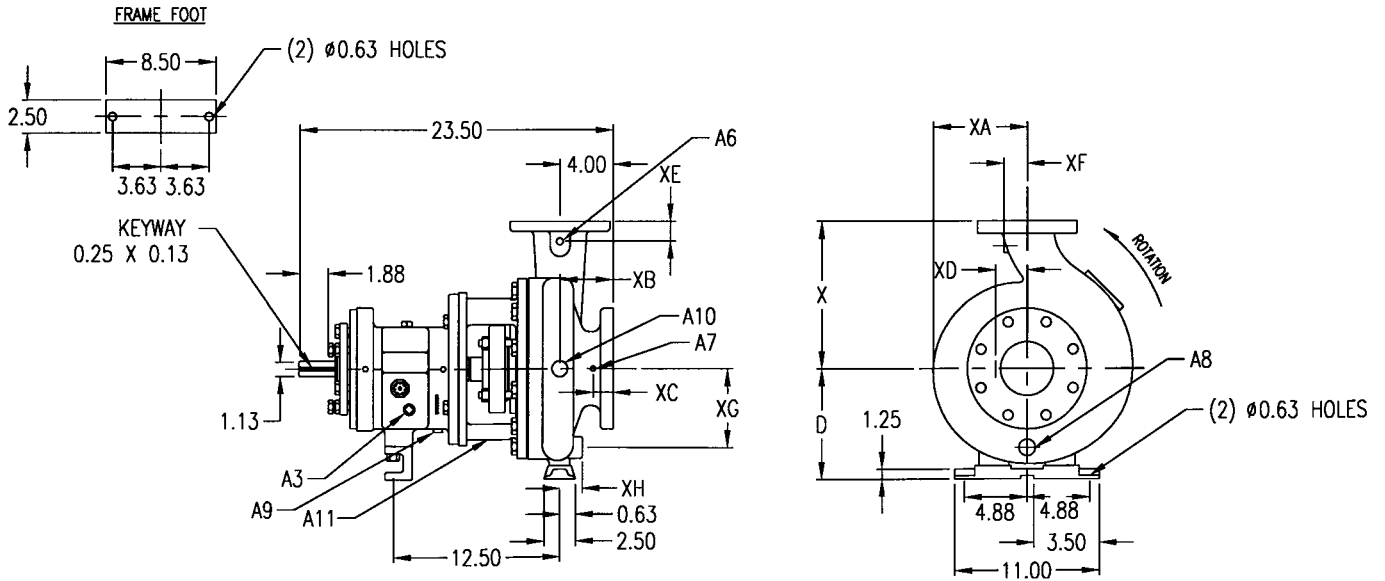

A3	A6 ①	A7 ①	A8 ②	A9	A10
✓ COOLING CONN STD., 1/2 NPT & 1 NPT	DISCH GAUGE TAP, 3/8 NPT	SUCT GAUGE TAP, 3/8 NPT	CASING DRAIN, 1/2 NPT	OIL DRAIN, 3/8 NPT	BY-PASS CONN., 1/2 NPT
A11					
✓ 1 NPT ADAPTER DRAIN, STD					

✓	Pump Size	Suction Size	Discharge Size	D	X	XA	XB	XC	XD	XE	XF	XG	XH	Wt Lb	Wt Kg
	8196 1.5X3-13 MTP	3	1.5	10.00	10.50	8.25	4.25	1.75	2.00	1.56	1.25	7.00	1.00	285	130
	8196 2X3-13 MTP	3	2	10.00	11.50	8.25	4.13	1.63	2.00	1.63	1.50	7.44	1.25	315	143
	8196 3X4-13 MTP	4	3	10.00	12.50	8.50	4.00	1.38	2.63	1.88	2.13	7.88	1.69	365	166
	8196 4X6-13 MTP	6	4	10.00	13.50	8.69	3.88	②	②	2.13	2.50	8.38	2.63	440	200

✓	Suction & Discharge Flange ANSI Lb Rating and Type (Select One)			
	150 Flat Face	150 Raised Face	300 Flat Face ③	300 Raised Face ③

Notes - Only items marked will be furnished. All dimensions are in inches

- ① Not available or not applicable on 4x6-13
- ② Standard on to Ductile Iron and 316 Stainless Steel construction
- ③ Not applicable to Ductile Iron construction

Customer _____ Purchase Order No. _____ Service _____

Pump Size _____ Material _____ Item _____

Total Head Feet _____ GPM _____ Rpm _____

Serial No. _____ Marks _____

Date _____ Signed _____

Certified for Approval Construction

PROCESS PUMPS SINGLE STAGE END
SUCTION ANSI Standard Dimensions
Series 8196 - 13 Inch MTP
Frame/Sealing Options

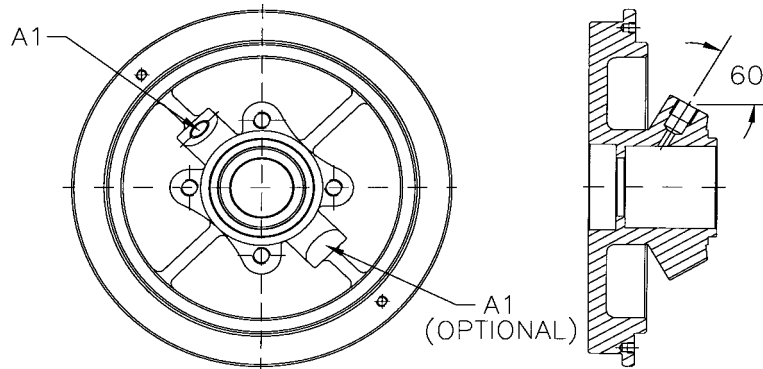
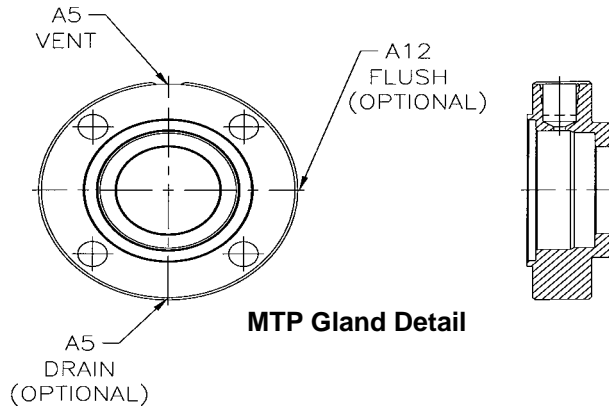

Number	Size	Quantity	Purpose	Furnished	
				Yes	No
A1	3/8 NPT	1	Lantern Ring Sealing	✓	
A1 (Optional)	3/8 NPT	1	Lantern Ring Drain		
A5	1/2 NPT	1	Vent Connection for Mechanical Seal	✓	
A5 (Optional)	1/2 NPT	1	Drain Connection for Mechanical Seal		
A12 (Optional)	1/2 NPT	1	Flush Connection for Mechanical Seal		

Pump Options (Select One in Each Group)	
Stuffing Box	Standard
	Taper Bore
	Large Bore
Bearing Lubrication	Oil
	Oil Mist
	Greased
	Greased for Life
Shaft	Sleeved
	Non-Sleeved
Box Cover Sealing	Packing Gland
	Mechanical Seal with Flush Gland
	Mechanical Seal with Vent and Drain Gland
	Less Gland

Customer _____ Purchase Order No. _____ Service _____
 Pump Size _____ Material _____ Item _____
 Total Head Feet _____ GPM _____ Rpm _____
 Serial No. _____ Marks _____
 Date _____ Signed _____

Certified for Approval Construction



PROCESS PUMPS SINGLE STAGE END SUCTION
ANSI Standard Dimensions
Series 8196 - 10 Inch LTP Frame

Pump Dimensions

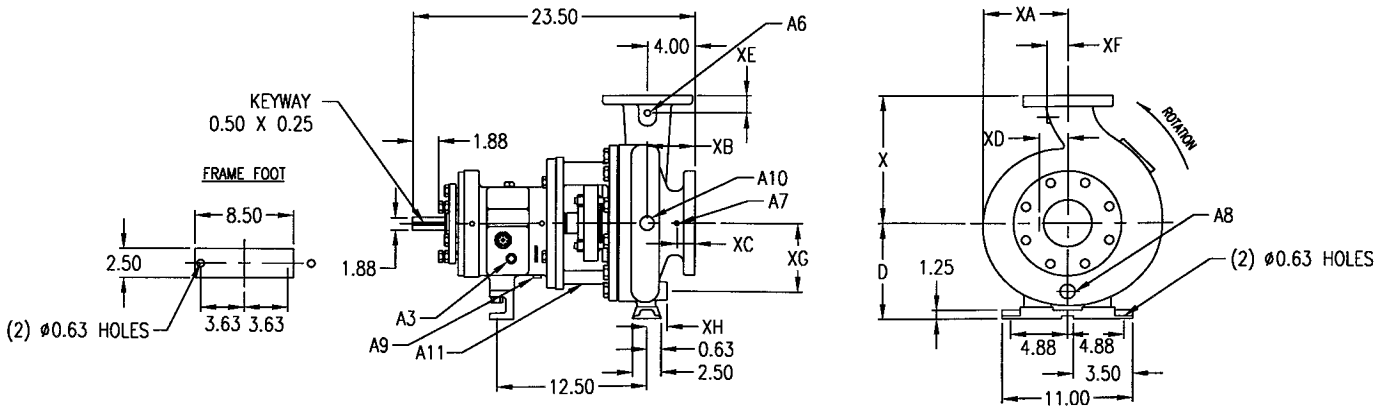

<input checked="" type="checkbox"/>	A3	<input checked="" type="checkbox"/>	A6 ①	<input checked="" type="checkbox"/>	A7 ①	<input checked="" type="checkbox"/>	A8 ②	<input checked="" type="checkbox"/>	A9	<input checked="" type="checkbox"/>	A10
	COOLING CONN STD., 1/2 NPT & 1 NPT		DISCH GAUGE TAP, 3/8 NPT		SUCT GAUGE TAP, 3/8 NPT		CASING DRAIN, 1/2 NPT		OIL DRAIN, 3/8 NPT		BY-PASS CONN., 1/2 NPT
	A11										
<input checked="" type="checkbox"/>	1 NPT ADAPTER DRAIN, STD										

✓	Pump Size	Suction Size	Discharge Size	D	X	XA	XB	XC	XD	XE	XF	XG	XH	Y	Wt Lb	Wt Kg
	8196 1X2-10 LTP	2	1	8.25	8.50	6.00	4.13	1.63	1.75	1.25	1.00	5.38	1.00	4.00	255	116
	8196 1.5X3-10 LTP	3	1.5	8.25	8.50	6.75	4.25	1.63	2.38	1.31	1.00	5.31	0.94	4.00	255	116
	8196 2X3-10 LTP	3	2	8.25	9.50	6.75	4.13	1.63	2.38	1.63	1.31	5.56	1.13	4.00	265	120
	8196 3X4-10 LTP	4	3	8.25	11.00	6.75	4.00	1.63	2.63	1.88	1.75	5.88	1.50	4.00	300	136
	8196 4X6-10 LTP	6	4	10.00	13.50	6.88	3.56	①	①	2.13	2.44	7.25	2.50	4.00	340	155

<input checked="" type="checkbox"/>	Suction & Discharge Flange ANSI Lb Rating and Type (Select One)			
	<input type="checkbox"/> 150 Flat Face	<input type="checkbox"/> 150 Raised Face	<input checked="" type="checkbox"/> 300 Flat Face ③	<input checked="" type="checkbox"/> 300 Raised Face ③

Notes - Only items marked will be furnished. All dimensions are in inches

- ① Not available or not applicable on 4x6-10
- ② Standard on to Ductile Iron and 316 Stainless Steel construction
- ③ Not applicable to Ductile Iron construction

Customer _____ Purchase Order No. _____ Service _____
 Pump Size _____ Material _____ Item _____
 Total Head Feet _____ GPM _____ Rpm _____
 Serial No. _____ Marks _____
 Date _____ Signed _____

Certified for Approval Construction

PROCESS PUMPS SINGLE STAGE END
SUCTION ANSI Standard Dimensions Series
8196 10 Inch LTP



Frame/Sealing Options

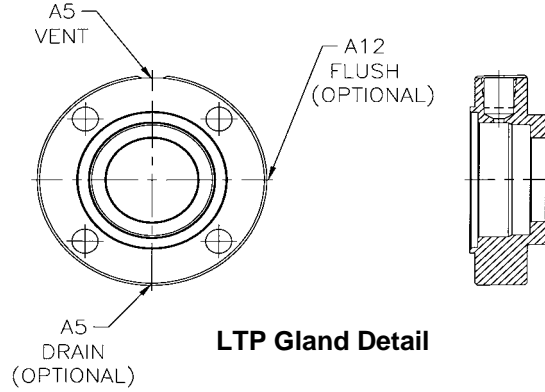

LTP Gland Detail

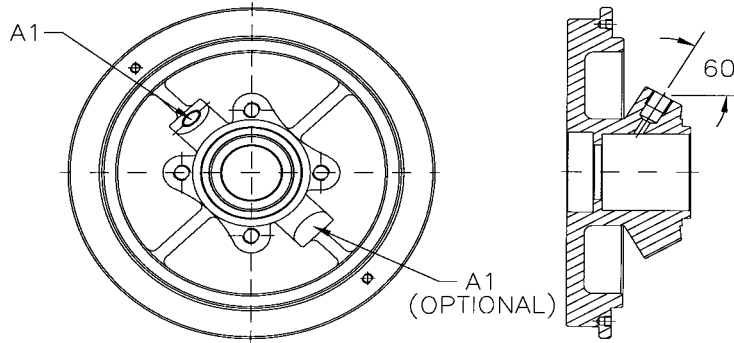

LTP Stuffing Box Detail

Number	Size	Quantity	Purpose	Furnished	
				Yes	No
A1	3/8 NPT	1	Lantern Ring Sealing	✓	
A1 (Optional)	3/8 NPT	1	Lantern Ring Drain		
A5	1/2 NPT	1	Vent Connection for Mechanical Seal	✓	
A5 (Optional)	1/2 NPT	1	Drain Connection for Mechanical Seal		
A12 (Optional)	1/2 NPT	1	Flush Connection for Mechanical Seal		

Pump Options (Select One in Each Group)	
Stuffing Box	Standard
	Taper Bore
	Large Bore
Bearing Lubrication	Oil
	Oil Mist
	Greased
	Greased for Life
Shaft	Sleeved
	Non-Sleeved
Box Cover Sealing	Packing Gland
	Mechanical Seal with Flush Gland
	Mechanical Seal with Vent and Drain Gland
	Less Gland

Customer _____ Purchase Order No. _____ Service _____
 Pump Size _____ Material _____ Item _____
 Total Head Feet _____ GPM _____ Rpm _____
 Serial No. _____ Marks _____
 Date _____ Signed _____

Certified for Approval Construction



PROCESS PUMPS SINGLE STAGE END
SUCTION ANSI Standard Dimensions Series
8196 - 13 Inch LTP Frame

Pump Dimensions

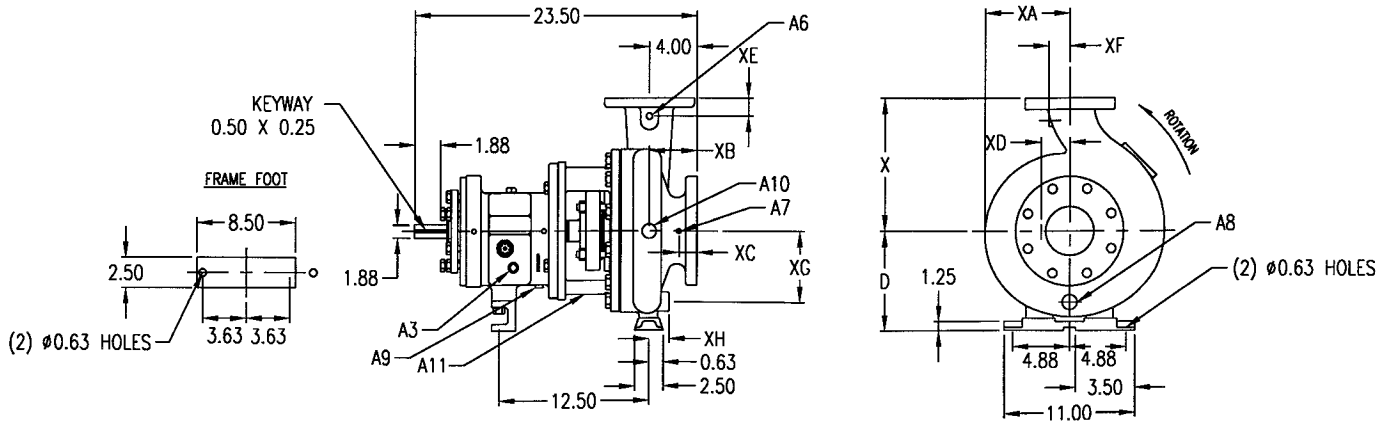

<input checked="" type="checkbox"/>	A3	A6 ①	A7 ①	A8 ②	A9	A10
<input checked="" type="checkbox"/>	COOLING CONN STD., 1/2 NPT & 1 NPT	DISCH GAUGE TAP, 3/8 NPT	SUCT GAUGE TAP, 3/8 NPT	CASING DRAIN, 1/2 NPT	OIL DRAIN, 3/8 NPT	BY-PASS CONN., 1/2 NPT
A11						
<input checked="" type="checkbox"/>	1 NPT ADAPTER DRAIN, STD					

<input checked="" type="checkbox"/>	Pump Size	Suction Size	Discharge Size	D	X	XA	XB	XC	XD	XE	XF	XG	XH	Wt Lb	Wt Kg
	8196 1.5X3-13 LTP	3	1.5	10.00	10.50	8.25	4.25	1.75	2.06	1.56	1.25	7.00	1.00	285	130
	8196 2X3-13 LTP	3	2	10.00	11.50	8.25	4.13	1.63	2.19	1.63	1.50	7.44	1.25	315	143
	8196 3X4-13 LTP	4	3	10.00	12.50	8.50	4.00	1.38	2.63	1.88	2.13	7.88	1.69	365	166
	8196 4X6-13 LTP	6	4	10.00	13.50	8.69	3.88	②	②	2.13	2.50	8.38	2.63	440	200

<input checked="" type="checkbox"/>	Suction & Discharge Flange ANSI Lb Rating and Type (Select One)			
	150 Flat Face	150 Raised Face	300 Flat Face ③	300 Raised Face ③

Notes - Only items marked will be furnished. All dimensions are in inches

- ① Not available or not applicable on 4x6-13
- ② Standard on to Ductile Iron and 316 Stainless Steel construction
- ③ Not applicable to Ductile Iron construction

Customer _____ Purchase Order No. _____ Service _____

Pump Size _____ Material _____ Item _____

Total Head Feet _____ GPM _____ Rpm _____

Serial No. _____ Marks _____

Date _____ Signed _____

Certified for Approval Construction

PROCESS PUMPS SINGLE STAGE END SUCTION
ANSI Standard Dimensions Series 8196 - 13 Inch LTP
Frame/Sealing Options



Peerless Pump Company
 Indianapolis, IN 46207-7026

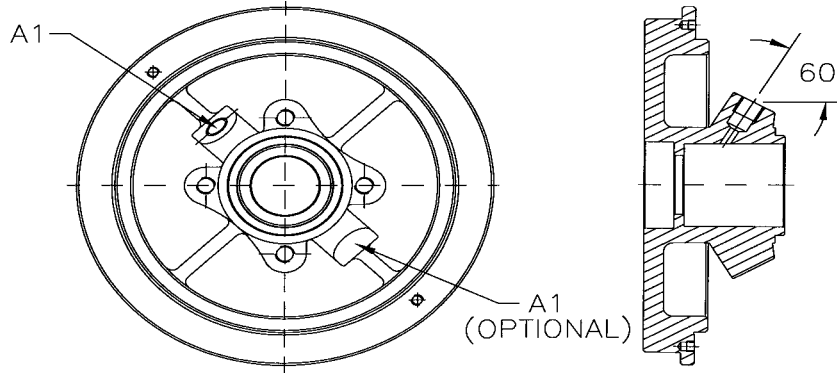
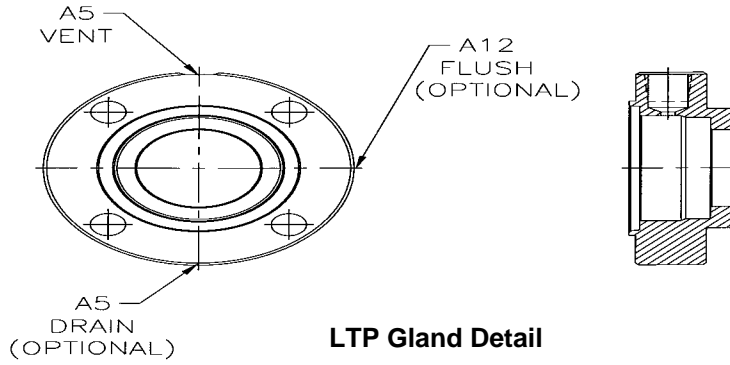

Number	Size	Quantity	Purpose	Furnished	
				Yes	No
A1	3/8 NPT	1	Lantern Ring Sealing	✓	
A1 (Optional)	3/8 NPT	1	Lantern Ring Drain		
A5	1/2 NPT	1	Vent Connection for Mechanical Seal	✓	
A5 (Optional)	1/2 NPT	1	Drain Connection for Mechanical Seal		
A12 (Optional)	1/2 NPT	1	Flush Connection for Mechanical Seal		

Pump Options (Select One in Each Group)	
Stuffing Box	Standard
	Taper Bore
	Large Bore
Bearing Lubrication	Oil
	Oil Mist
	Greased
	Greased for Life
Shaft	Sleeved
	Non-Sleeved
Box Cover Sealing	Packing Gland
	Mechanical Seal with Flush Gland
	Mechanical Seal with Vent and Drain Gland
	Less Gland

Customer _____ Purchase Order No. _____ Service _____
 Pump Size _____ Material _____ Item _____
 Total Head Feet _____ GPM _____ Rpm _____
 Serial No. _____ Marks _____
 Date _____ Signed _____

Certified for Approval Construction



Pump Dimensions

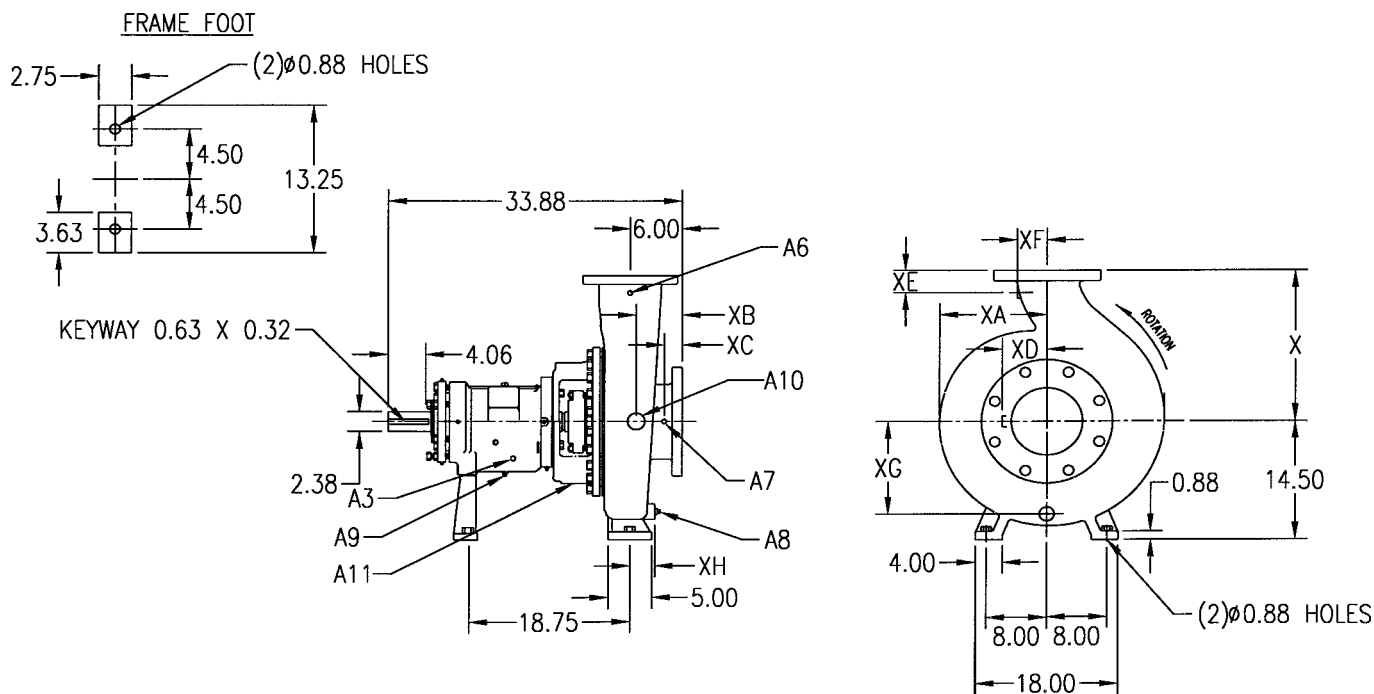

A3	A6	A7	A8 ①	A9	A10
<input checked="" type="checkbox"/> COOLING CONN STD., 1/2 NPT & 1 NPT	DISCH GAUGE TAP, 3/8 NPT	SUCT GAUGE TAP, 3/8 NPT	CASING DRAIN, 1/2 NPT	OIL DRAIN, 3/8 NPT	BY-PASS CONN., 1/2 NPT
A11					
<input checked="" type="checkbox"/> 1 NPT ADAPTER DRAIN, STD					

<input checked="" type="checkbox"/>	Pump Size	Suction Size	Discharge Size	X	XA	XB	XC	XD	XE	XF	XG	XH	Wt Lb	Wt Kg
	8196 6X8 -13 XLTP	8	6	16.00	9.38	6.31	2.38	4.50	2.38	3.44	9.81	2.31	570	259
	8196 8X10-13 XLTP	10	8	18.00	10.13	5.81	2.38	5.38	2.38	4.38	11.00	3.63	670	305
	8196 6 X 8-15 XLTP	8	6	18.00	10.63	6.44	2.38	4.69	2.38	3.50	11.13	2.13	640	291
	8196 8X10-15 XLTP	10	8	19.00	11.38	5.69	2.38	5.75	2.38	4.50	12.13	4.13	740	336
	8196 8X10-15G XLTP	10	8	19.00	11.00	6.00	2.38	5.38	2.38	4.50	11.63	3.00	740	336

<input checked="" type="checkbox"/>	Suction & Discharge Flange ANSI Lb Rating and Type (Select One)			
	150 Flat Face	150 Raised Face	300 Flat Face ②	300 Raised Face ②

Notes - Only items marked will be furnished. All dimensions are in inches

① Standard on to Ductile Iron and 316 Stainless Steel construction

② Not applicable to Ductile Iron construction

Customer _____ Purchase Order No. _____ Service _____
 Pump Size _____ Material _____ Item _____
 Total Head Feet _____ GPM _____ Rpm _____
 Serial No. _____ Marks _____
 Date _____ Signed _____

Certified for Approval Construction
4853902

Drawing Number

PROCESS PUMPS SINGLE STAGE END SUCTION
ANSI Standard Dimensions Series 8196 - XLTP
Frame/Sealing Options

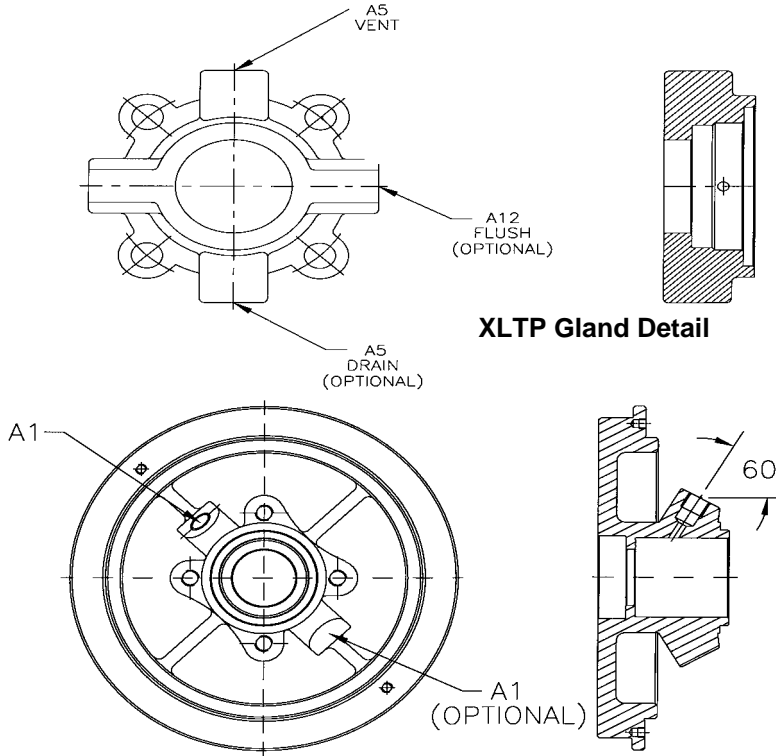

XLTP Stuffing Box Detail

Number	Size	Quantity	Purpose	Furnished	
				Yes	No
A1	3/8 NPT	1	Lantern Ring Sealing	✓	
A1 (Optional)	3/8 NPT	1	Lantern Ring Drain		
A5	1/2 NPT	1	Vent Connection for Mechanical Seal	✓	
A5 (Optional)	1/2 NPT	1	Drain Connection for Mechanical Seal		
A12 (Optional)	1/2 NPT	1	Flush Connection for Mechanical Seal		

Pump Options (Select One in Each Group)	
Stuffing Box	Standard
	Taper Bore
	Large Bore
Bearing Lubrication	Oil
	Oil Mist
	Greased
	Greased for Life
Shaft	Sleeved
	Non-Sleeved
Box Cover Sealing	Packing Gland
	Mechanical Seal with Flush Gland
	Mechanical Seal with Vent and Drain Gland
	Less Gland

Customer _____ Purchase Order No. _____ Service _____
Pump Size _____ Material _____ Item _____
Total Head Feet _____ GPM _____ Rpm _____
Serial No. _____ Marks _____
Date _____ Signed _____

Certified for Approval Construction



PROCESS PUMPS SINGLE STAGE END
SUCTION ANSI Standard Dimensions Series 8196
- STP Frame

Unit Dimensional Outline - Fabricated Steel Base

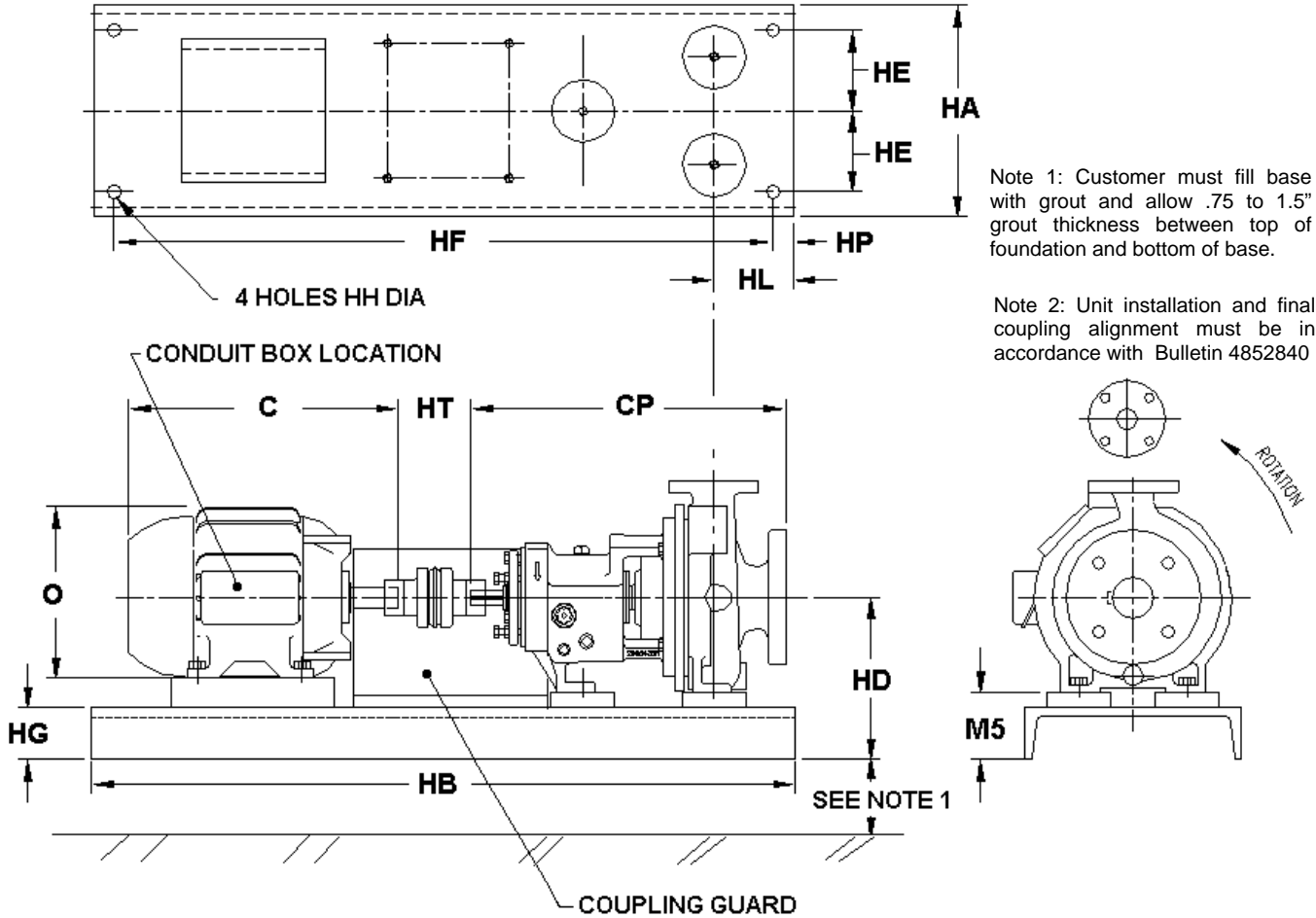

Note 1: Customer must fill base with grout and allow .75 to 1.5" grout thickness between top of foundation and bottom of base.

Note 2: Unit installation and final coupling alignment must be in accordance with Bulletin 4852840

✓	8196-Frame Size	Base No	Motor Frame	C Max	O Max	HA	HB	HD	HE	HF	HG	HL	HH	HP	HT	M5	Motor Wt Lb including Cplg	Base, Cplg Guard Wt Lb
	STP	139	143T	12.69	7.50	12.00	39.00	9.00	4.50	36.50	3.17	4.50	0.75	1.25	3.75	3.75	50	87
	STP	139	145T	12.69	7.50	12.00	39.00	9.00	4.50	36.50	3.17	4.50	0.75	1.25	3.75	3.75	55	87
	STP	139	182T	15.19	9.88	12.00	39.00	9.00	4.50	36.50	3.17	4.50	0.75	1.25	3.75	3.75	85	102
	STP	139	184T	16.19	9.88	12.00	39.00	9.00	4.50	36.50	3.17	4.50	0.75	1.25	3.75	3.75	100	102
	STP	148	213T	18.56	11.25	15.00	48.00	10.50	6.00	45.50	3.40	4.50	0.75	1.25	3.75	5.25	150	102
	STP	148	215T	20.06	11.25	15.00	48.00	10.50	6.00	45.50	3.40	4.50	0.75	1.25	3.75	5.25	170	102
	STP	148	254T	24.56	13.00	15.00	48.00	10.50	6.00	45.50	3.40	4.50	0.75	1.25	3.75	5.25	245	157
	STP	148	256T	25.00	13.25	15.00	48.00	10.50	6.00	45.50	3.40	4.50	0.75	1.25	3.75	5.25	285	157
	STP	153	284T	27.44	14.75	18.00	53.00	12.88	7.50	50.50	4.00	4.50	0.75	1.25	3.75	7.63	390	157
	STP	153	284TS	26.06	14.75	18.00	53.00	12.88	7.50	50.50	4.00	4.50	0.75	1.25	3.75	7.63	360	157
	STP	153	286T	27.69	14.75	18.00	53.00	12.88	7.50	50.50	4.00	4.50	0.75	1.25	3.75	7.63	435	157
	STP	153	286TS	26.25	14.75	18.00	53.00	12.88	7.50	50.50	4.00	4.50	0.75	1.25	3.75	7.63	425	157

Customer _____ Purchase Order No. _____ Service _____
 Pump Size _____ Material _____ Item _____
 GPM _____ Total Head in Feet _____ Rpm _____ Marks _____
 Motor Manufacturer _____ Enclosure _____ Motor Features _____
 Hp _____ Volts _____ Phase _____ Hertz _____
 By _____ Date _____ Certified for Approval Construction

All Dimensions are in inches

**PROCESS PUMPS SINGLE STAGE END
SUCTION ANSI Standard Dimensions Series
8196 -MTP, LTP Frame**



Peerless Pump Company
Indianapolis, IN 46207-7026

Unit Dimensional Outline Fabricated Steel Base

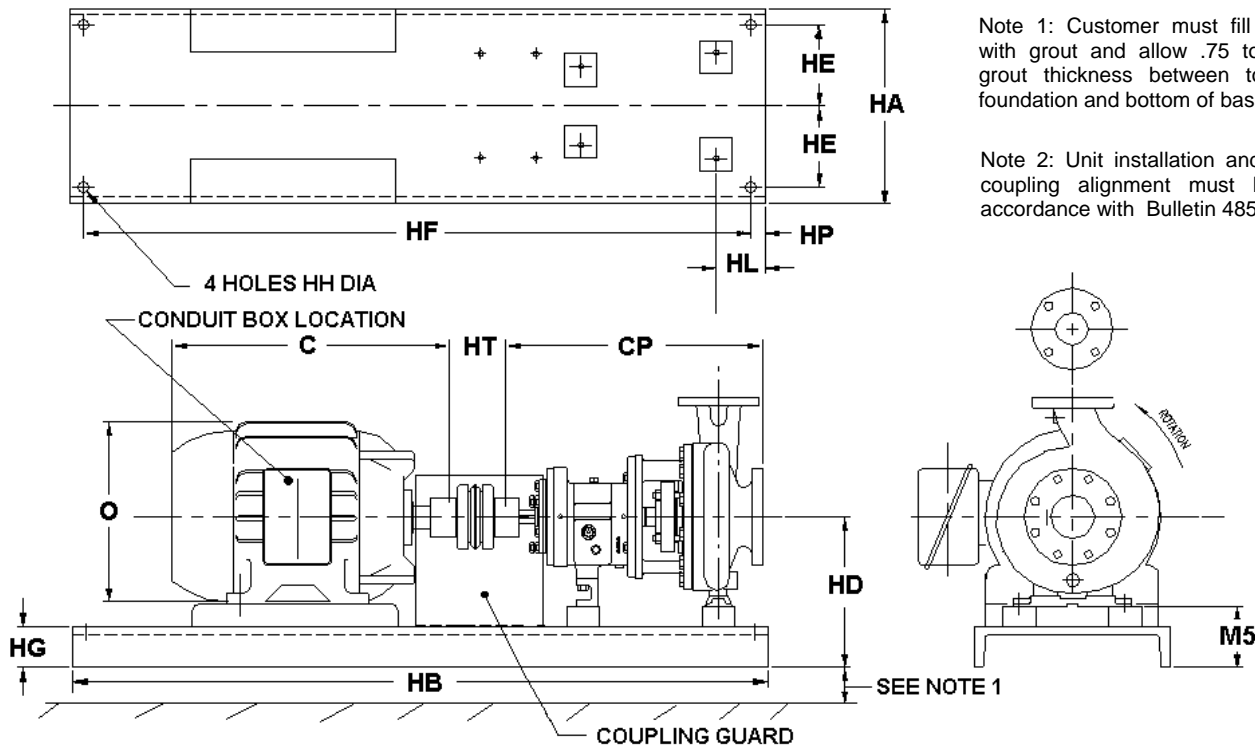

Note 1: Customer must fill base with grout and allow .75 to 1.5" grout thickness between top of foundation and bottom of base.

Note 2: Unit installation and final coupling alignment must be in accordance with Bulletin 4852840

Dimensions apply only to Pump Sizes 2x3-6, 2x3-8, 3x4-8, 3x4-8G, 1x2-10, 1-1/2x2-10, 2x3-10, 3x4-10

8196 Frame Size	Base No.	Motor Frame	C Max	O Max	HA	HB	HD	HE	HF	HG	HL	HH	HP	HT	M5	Mtr Wt Lb Including Cplg	Base, Cplg Guard Wt Lb
✓ MTP & LTP	245	143T	12.69	7.50	12.00	45.00	12.00	4.50	42.50	3.17	4.50	0.75	1.25	3.75	3.75	40	189
MTP & LTP	245	145T	12.69	7.50	12.00	45.00	12.00	4.50	42.50	3.17	4.50	0.75	1.25	3.75	3.75	45	189
MTP & LTP	245	182T	15.19	9.88	12.00	45.00	12.00	4.50	42.50	3.17	4.50	0.75	1.25	3.75	3.75	65	189
MTP & LTP	245	184T	16.19	9.88	12.00	45.00	12.00	4.50	42.50	3.17	4.50	0.75	1.25	3.75	3.75	75	189
MTP & LTP	252	213T	18.56	11.25	15.00	52.00	12.38	6.00	49.50	3.40	4.50	0.75	1.25	3.75	4.13	150	189
MTP & LTP	252	215T	20.06	11.25	15.00	52.00	12.38	6.00	49.50	3.40	4.50	0.75	1.25	3.75	4.13	160	189
MTP & LTP	258	254T	24.56	13.00	18.00	58.00	13.00	7.50	55.50	4.00	4.50	1.00	1.25	3.75	4.75	255	189
MTP & LTP	258	256T	25.00	13.25	18.00	58.00	13.00	7.50	55.50	4.00	4.50	1.00	1.25	3.75	4.75	280	194
MTP & LTP	258	284T	27.44	14.75	18.00	58.00	13.00	7.50	55.50	4.00	4.50	1.00	1.25	3.75	4.75	375	194
MTP & LTP	258	284TS	26.06	14.75	18.00	58.00	13.00	7.50	55.50	4.00	4.50	1.00	1.25	3.75	4.75	345	194
MTP & LTP	258	286T	27.69	14.75	18.00	58.00	13.00	7.50	55.50	4.00	4.50	1.00	1.25	3.75	4.75	430	194
MTP & LTP	258	286TS	26.25	14.75	18.00	58.00	13.00	7.50	55.50	4.00	4.50	1.00	1.25	3.75	4.75	380	194
MTP & LTP	264	324T	30.44	16.69	18.00	64.00	13.88	7.50	61.50	4.00	4.50	1.00	1.25	3.75	5.63	575	220
MTP & LTP	264	324TS	28.94	16.69	18.00	64.00	13.88	7.50	61.50	4.00	4.50	1.00	1.25	3.75	5.63	485	220
MTP & LTP	264	326T	31.19	16.69	18.00	64.00	13.88	7.50	61.50	4.00	4.50	1.00	1.25	3.75	5.63	640	220
MTP & LTP	264	326TS	29.69	16.69	18.00	64.00	13.88	7.50	61.50	4.00	4.50	1.00	1.25	3.75	5.63	570	220
MTP & LTP	264	364T	33.44	18.50	18.00	64.00	13.88	7.50	61.50	4.00	4.50	1.00	1.25	3.75	5.63	810	220
MTP & LTP	264	364TS	31.31	18.50	18.00	64.00	13.88	7.50	61.50	4.00	4.50	1.00	1.25	3.75	5.63	755	308
MTP & LTP	264	365T	33.44	18.50	18.00	64.00	13.88	7.50	61.50	4.00	4.50	1.00	1.25	3.75	5.63	950	308
MTP & LTP	264	365TS	31.31	18.50	18.00	64.00	13.88	7.50	61.50	4.00	4.50	1.00	1.25	3.75	5.63	865	308
MTP & LTP	268	404T	38.31	21.31	26.00	68.00	14.88	9.50	65.50	4.00	4.50	1.00	1.25	3.75	6.63	1080	308
MTP & LTP	268	404TS	35.31	21.31	26.00	68.00	14.88	9.50	65.50	4.00	4.50	1.00	1.25	3.75	6.63	1080	308
MTP & LTP	268	405T	38.31	21.31	26.00	68.00	14.88	9.50	65.50	4.00	4.50	1.00	1.25	3.75	6.63	1110	308
MTP & LTP	268	405TS	35.31	21.31	26.00	68.00	14.88	9.50	65.50	4.00	4.50	1.00	1.25	3.75	6.63	1110	308

Customer _____ Purchase Order No. _____ Service _____
Pump Size _____ Material _____ Item _____
GPM _____ Total Head in Feet _____ Rpm _____ Marks _____
Motor Manufacturer _____ Enclosure _____ Motor Features _____
Hp _____ Volts _____ Phase _____ Hertz _____
By _____ Date _____ Certified for Approval Construction
All Dimensions are in inches



PROCESS PUMPS SINGLE STAGE END SUCTION
ANSI Standard Dimensions Series 8196 - MTP, LTP
Frame

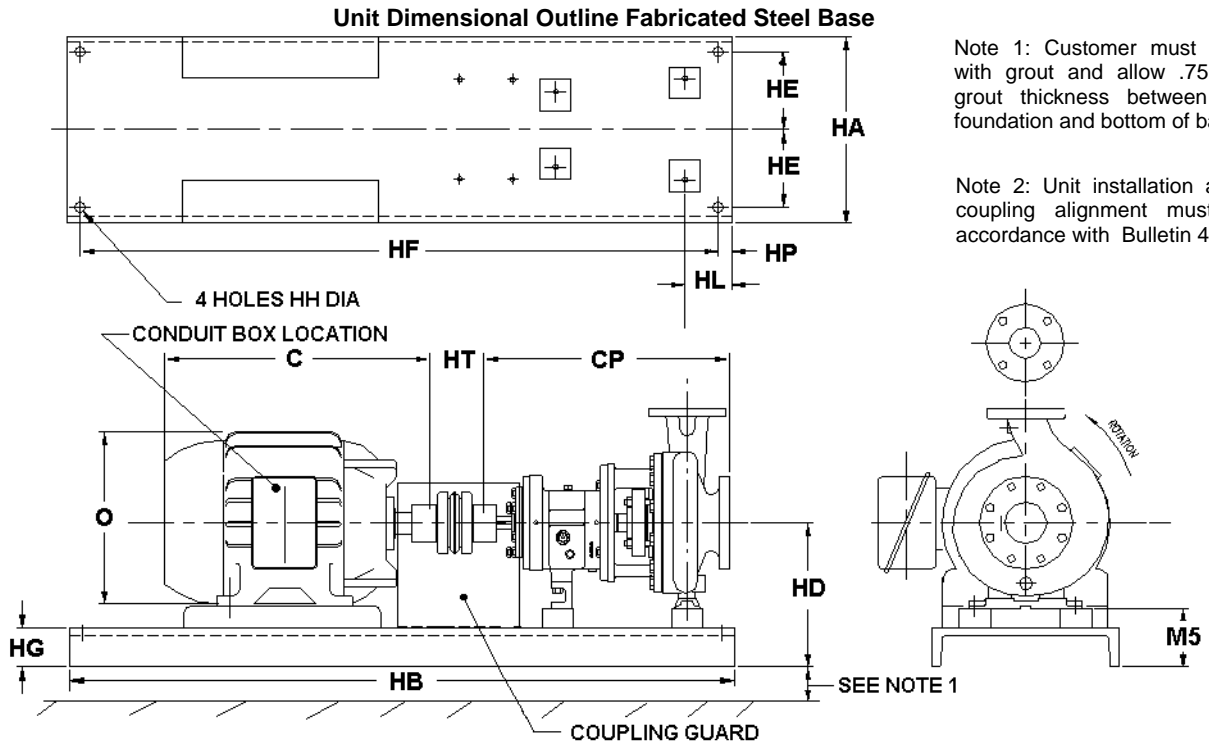

Note 1: Customer must fill base with grout and allow .75 to 1.5" grout thickness between top of foundation and bottom of base.

Note 2: Unit installation and final coupling alignment must be in accordance with Bulletin 4852840

Dimensions apply only to Pump Sizes 4x6-10, 1-1/2x3-13, 2x3-13, 3x4-13, 4x6-13

8196 Frame Size	Base No.	Motor Frame	C Max	O Max	HA	HB	HD	HE	HF	HG	HL	HH	HP	HT	M5	Mtr Wt Lb including Cplg	Base, Cplg Guard Wt Lb
✓ MTP & LTP	245	182T	15.19	9.88	12.00	45.00	13.75	4.50	42.50	3.17	4.50	0.75	1.25	3.75	3.75	65	189
MTP & LTP	245	184T	16.19	9.88	12.00	45.00	13.75	4.50	42.50	3.17	4.50	0.75	1.25	3.75	3.75	75	189
MTP & LTP	252	213T	18.56	11.25	15.00	52.00	14.13	6.00	49.50	3.40	4.50	0.75	1.25	3.75	4.13	150	189
MTP & LTP	252	215T	20.06	11.25	15.00	52.00	14.13	6.00	49.50	3.40	4.50	0.75	1.25	3.75	4.13	160	189
MTP & LTP	258	254T	24.56	13.00	18.00	58.00	14.75	7.50	55.50	4.00	4.50	1.00	1.25	3.75	4.75	255	194
MTP & LTP	258	256T	25.00	13.25	18.00	58.00	14.75	7.50	55.50	4.00	4.50	1.00	1.25	3.75	4.75	280	194
MTP & LTP	258	284T	27.44	14.75	18.00	58.00	14.75	7.50	55.50	4.00	4.50	1.00	1.25	3.75	4.75	375	194
MTP & LTP	258	284TS	26.06	14.75	18.00	58.00	14.75	7.50	55.50	4.00	4.50	1.00	1.25	3.75	4.75	345	194
MTP & LTP	258	286T	27.69	14.75	18.00	58.00	14.75	7.50	55.50	4.00	4.50	1.00	1.25	3.75	4.75	430	194
MTP & LTP	258	286TS	26.25	14.75	18.00	58.00	14.75	7.50	55.50	4.00	4.50	1.00	1.25	3.75	4.75	380	194
MTP & LTP	264	324T	30.44	16.69	18.00	64.00	14.75	7.50	61.50	4.00	4.50	1.00	1.25	3.75	4.75	575	220
MTP & LTP	264	324TS	28.94	16.69	18.00	64.00	14.75	7.50	61.50	4.00	4.50	1.00	1.25	3.75	4.75	485	220
MTP & LTP	264	326T	31.19	16.69	18.00	64.00	14.75	7.50	61.50	4.00	4.50	1.00	1.25	3.75	4.75	640	220
MTP & LTP	264	326TS	29.69	16.69	18.00	64.00	14.75	7.50	61.50	4.00	4.50	1.00	1.25	3.75	4.75	570	220
MTP & LTP	264	364T	33.44	18.50	18.00	64.00	14.75	7.50	61.50	4.00	4.50	1.00	1.25	3.75	4.75	810	220
MTP & LTP	264	364TS	31.31	18.50	18.00	64.00	14.75	7.50	61.50	4.00	4.50	1.00	1.25	3.75	4.75	755	220
MTP & LTP	264	365T	33.44	18.50	18.00	64.00	14.75	7.50	61.50	4.00	4.50	1.00	1.25	3.75	4.75	950	220
MTP & LTP	264	365TS	31.31	18.50	18.00	64.00	14.75	7.50	61.50	4.00	4.50	1.00	1.25	3.75	4.75	865	220
MTP & LTP	268	404T	38.31	21.31	18.00	68.00	14.88	9.50	65.50	4.00	4.50	1.00	1.25	3.75	4.88	1080	308
MTP & LTP	268	404TS	35.31	21.31	18.00	68.00	14.88	9.50	65.50	4.00	4.50	1.00	1.25	3.75	4.88	1080	308
MTP & LTP	268	405T	38.31	21.31	18.00	68.00	14.88	9.50	65.50	4.00	4.50	1.00	1.25	3.75	4.88	1110	308
MTP & LTP	268	405TS	35.31	21.31	18.00	68.00	14.88	9.50	65.50	4.00	4.50	1.00	1.25	3.75	4.88	1110	308
MTP & LTP	280	444T	44.62	23.38	26.00	80.00	15.88	9.50	77.50	4.00	4.50	1.00	1.25	3.75	5.88	1500	360
MTP & LTP	280	444TS	40.88	23.38	26.00	80.00	15.88	9.50	77.50	4.00	4.50	1.00	1.25	3.75	5.88	1500	360
MTP & LTP	280	445T	45.88	23.38	26.00	80.00	15.88	9.50	77.50	4.00	4.50	1.00	1.25	3.75	5.88	1710	360
MTP & LTP	280	445TS	42.13	23.38	26.00	80.00	15.88	9.50	77.50	4.00	4.50	1.00	1.25	3.75	5.88	1675	360
MTP & LTP	280	447T	49.38	22.75	26.00	80.00	15.88	9.50	77.50	4.00	4.50	1.00	1.25	3.75	5.88	2320	360
MTP & LTP	280	447TS	45.63	22.75	26.00	80.00	15.88	9.50	77.50	4.00	4.50	1.00	1.25	3.75	5.88	2320	360
MTP & LTP	280	449T	55.13	24.13	26.00	80.00	15.88	9.50	77.50	4.00	4.50	1.00	1.25	3.75	5.88	2850	360
MTP & LTP	280	449TS	51.38	24.13	26.00	80.00	15.88	9.50	77.50	4.00	4.50	1.00	1.25	3.75	5.88	2850	360

Customer _____ Purchase Order No. _____ Service _____
 Pump Size _____ Material _____ Item _____
 GPM _____ Total Head in Feet _____ Rpm _____ Marks _____
 Motor Manufacturer _____ Enclosure _____ Motor Features _____
 Hp _____ Volts _____ Phase _____ Hertz _____
 By _____ Date _____ Certified for Approval Construction

All Dimensions are in inches

**PROCESS PUMPS SINGLE STAGE END
SUCTION ANSI Standard Dimensions
Series 8196 -XLTP Frame**



Peerless Pump Company
Indianapolis, IN 46207-7026

Unit Dimensional Outline Fabricated Steel Base

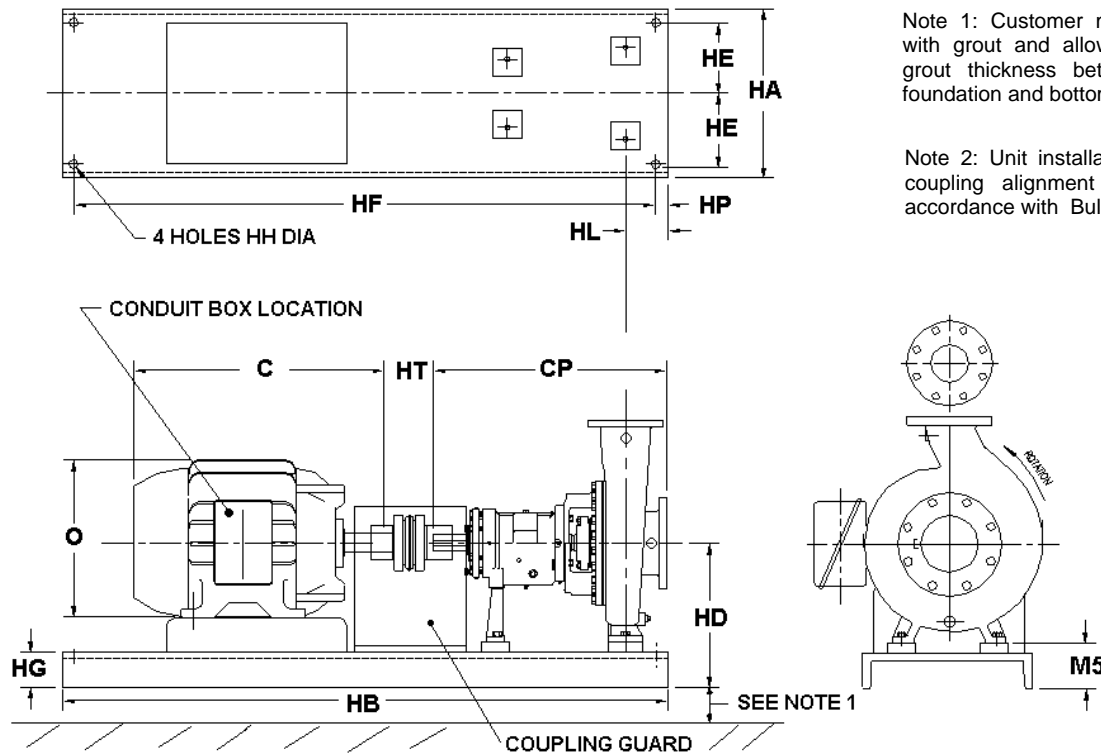

Note 1: Customer must fill base with grout and allow .75 to 1.5" grout thickness between top of foundation and bottom of base.

Note 2: Unit installation and final coupling alignment must be in accordance with Bulletin 4852840

✓	8196 Frame Size	Base No.	Motor Frame	C	O	HA	HB	HD	HE	HF	HG	HL	HH	HP	HT	M5	Motor Wt Lb Including Cplg	Base, Cplg, Guard Wt Lb
	XLTP	368	284T	27.44	14.75	26.00	68.00	19.25	9.50	65.50	4.00	6.50	1.00	1.25	5.25	4.75	410	395
	XLTP	368	284TS	26.06	14.75	26.00	68.00	19.25	9.50	65.50	4.00	6.50	1.00	1.25	5.25	4.75	380	395
	XLTP	368	286T	27.69	14.75	26.00	68.00	19.25	9.50	65.50	4.00	6.50	1.00	1.25	5.25	4.75	445	395
	XLTP	368	286TS	26.25	14.75	26.00	68.00	19.25	9.50	65.50	4.00	6.50	1.00	1.25	5.25	4.75	435	395
	XLTP	380	324T	30.44	16.69	26.00	80.00	19.25	9.50	77.50	4.00	6.50	1.00	1.25	5.25	4.75	560	500
	XLTP	380	324TS	28.94	16.69	26.00	80.00	19.25	9.50	77.50	4.00	6.50	1.00	1.25	5.25	4.75	540	500
	XLTP	380	326T	31.19	16.69	26.00	80.00	19.25	9.50	77.50	4.00	6.50	1.00	1.25	5.25	4.75	620	500
	XLTP	380	326TS	29.69	16.69	26.00	80.00	19.25	9.50	77.50	4.00	6.50	1.00	1.25	5.25	4.75	600	500
	XLTP	380	364T	33.44	18.50	26.00	80.00	19.25	9.50	77.50	4.00	6.50	1.00	1.25	5.25	4.75	795	500
	XLTP	380	364TS	31.31	18.50	26.00	80.00	19.25	9.50	77.50	4.00	6.50	1.00	1.25	5.25	4.75	780	500
	XLTP	380	365T	33.44	18.50	26.00	80.00	19.25	9.50	77.50	4.00	6.50	1.00	1.25	5.25	4.75	880	500
	XLTP	380	365TS	31.31	18.50	26.00	80.00	19.25	9.50	77.50	4.00	6.50	1.00	1.25	5.25	4.75	865	500
	XLTP	380	404T	38.31	21.31	26.00	80.00	19.25	9.50	77.50	4.00	6.50	1.00	1.25	5.25	4.75	1105	500
	XLTP	380	404TS	35.31	21.31	26.00	80.00	19.25	9.50	77.50	4.00	6.50	1.00	1.25	5.25	4.75	1105	500
	XLTP	380	405T	38.31	21.31	26.00	80.00	19.25	9.50	77.50	4.00	6.50	1.00	1.25	5.25	4.75	1215	500
	XLTP	380	405TS	35.31	21.31	26.00	80.00	19.25	9.50	77.50	4.00	6.50	1.00	1.25	5.25	4.75	1205	500
	XLTP	398	444T	44.62	23.38	26.00	98.00	19.25	9.50	95.50	4.00	6.50	1.00	1.25	5.25	4.75	1500	590
	XLTP	398	444TS	40.88	23.38	26.00	98.00	19.25	9.50	95.50	4.00	6.50	1.00	1.25	5.25	4.75	1500	590
	XLTP	398	445T	45.88	23.38	26.00	98.00	19.25	9.50	95.50	4.00	6.50	1.00	1.25	5.25	4.75	1710	590
	XLTP	398	445TS	42.13	23.38	26.00	98.00	19.25	9.50	95.50	4.00	6.50	1.00	1.25	5.25	4.75	1675	590
	XLTP	398	447T	49.38	22.75	26.00	98.00	19.25	9.50	95.50	4.00	6.50	1.00	1.25	5.25	4.75	2320	590
	XLTP	398	447TS	45.63	22.75	26.00	98.00	19.25	9.50	95.50	4.00	6.50	1.00	1.25	5.25	4.75	2320	590
	XLTP	398	449T	55.13	24.13	26.00	98.00	19.25	9.50	95.50	4.00	6.50	1.00	1.25	5.25	4.75	2850	590
	XLTP	398	449TS	51.38	24.13	26.00	98.00	19.25	9.50	95.50	4.00	6.50	1.00	1.25	5.25	4.75	2850	590

Customer _____ Purchase Order No. _____ Service _____
Pump Size _____ Material _____ Item _____
GPM _____ Total Head in Feet _____ Rpm _____ Marks _____
Motor Manufacturer _____ Enclosure _____ Motor Features _____
Hp _____ Volts _____ Phase _____ Hertz _____
By _____ Date _____ Certified for Approval Construction

All Dimensions are in inches

Drawing No. 4853906
Rev. 11-04



PROCESS PUMPS SINGLE STAGE END SUCTION
ANSI Standard Dimensions Series 8196 - STP
Frame

Unit Dimensional Outline - Cast Iron Drip Rim Base

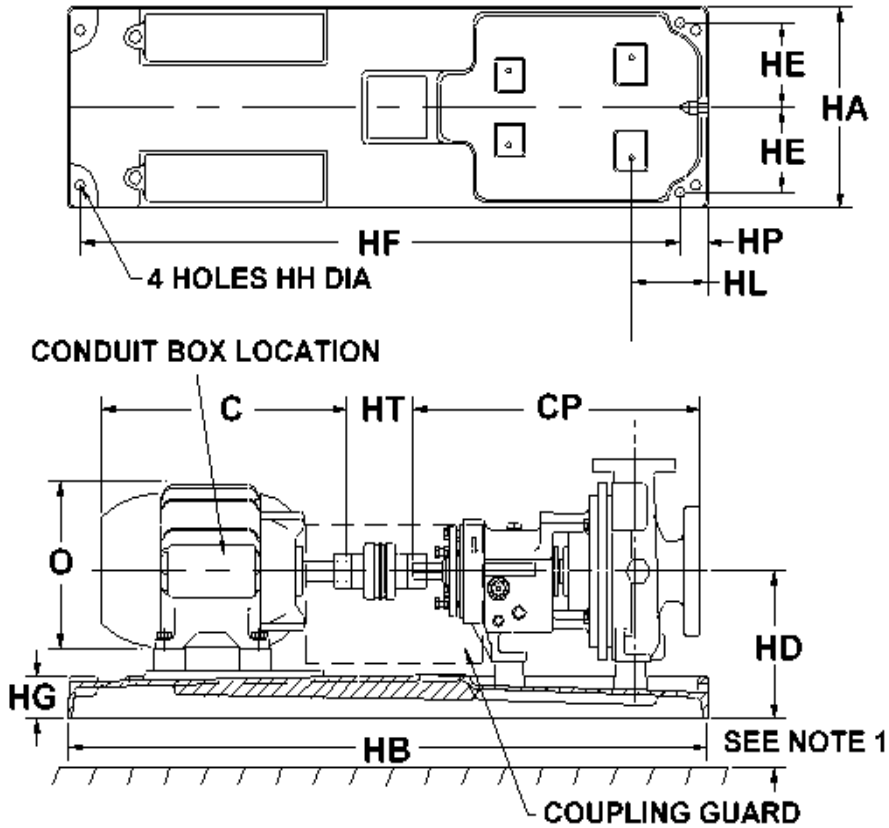

Note 1: Customer must fill base with grout and allow .75 to 1.5" grout thickness between top of foundation and bottom of base.

Note 2: Unit installation and final coupling alignment must be in accordance with Bulletin 4852840

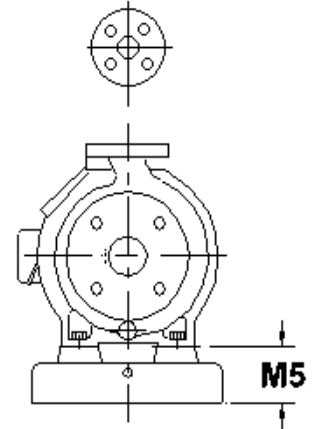

✓	8196-Frame Size	Base No	Motor Frame	C Max	O Max	HA	HB	HD	HE	HF	HG	HL	HH	HP	HT	M5	Motor Wt Lb including Cplg	Base, Cplg Guard Wt Lb
	STP	139	143T	12.69	7.50	12.25	39.00	8.88	4.50	36.50	3.25	4.50	0.75	1.25	3.75	3.62	50	134
	STP	139	145T	12.69	7.50	12.25	39.00	8.88	4.50	36.50	3.25	4.50	0.75	1.25	3.75	3.62	55	134
	STP	139	182T	15.19	9.88	12.25	39.00	8.88	4.50	36.50	3.25	4.50	0.75	1.25	3.75	3.62	85	134
	STP	139	184T	16.19	9.88	12.25	39.00	8.88	4.50	36.50	3.25	4.50	0.75	1.25	3.75	3.62	100	134
	STP	148	213T	18.56	11.25	15.25	48.00	10.38	6.00	45.50	3.50	4.50	0.75	1.25	3.75	5.12	150	226
	STP	148	215T	20.06	11.25	15.25	48.00	10.38	6.00	45.50	3.50	4.50	0.75	1.25	3.75	5.12	170	226
	STP	148	254T	24.56	13.00	15.25	48.00	10.38	6.00	45.50	3.50	4.50	0.75	1.25	3.75	5.12	245	226
	STP	148	256T	25.00	13.25	15.25	48.00	10.38	6.00	45.50	3.50	4.50	0.75	1.25	3.75	5.12	285	226
	STP	153	284T	27.44	14.75	18.25	53.00	12.75	7.50	50.50	3.50	4.50	0.75	1.25	3.75	7.50	390	352
	STP	153	284TS	26.06	14.75	18.25	53.00	12.75	7.50	50.50	3.50	4.50	0.75	1.25	3.75	7.50	360	352
	STP	153	286T	27.69	14.75	18.25	53.00	12.75	7.50	50.50	3.50	4.50	0.75	1.25	3.75	7.50	435	352
	STP	153	286TS	26.25	14.75	18.25	53.00	12.75	7.50	50.50	3.50	4.50	0.75	1.25	3.75	7.50	425	352

Customer _____ Purchase Order No. _____ Service _____

Pump Size _____ Material _____ Item _____

GPM _____ Total Head in Feet _____ Rpm _____ Marks _____

Motor Manufacturer _____ Enclosure _____ Motor Features _____

Hp _____ Volts _____ Phase _____ Hertz _____

By _____ Date _____ Certified for Approval Construction

All Dimensions are in inches

Drawing No. 4853919

PROCESS PUMPS SINGLE STAGE END
SUCTION ANSI Standard Dimensions Series
8196 -MTP, LTP Frame

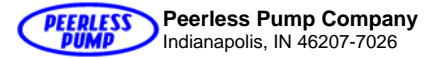

Unit Dimensional Outline Cast Iron Drip Rim Base

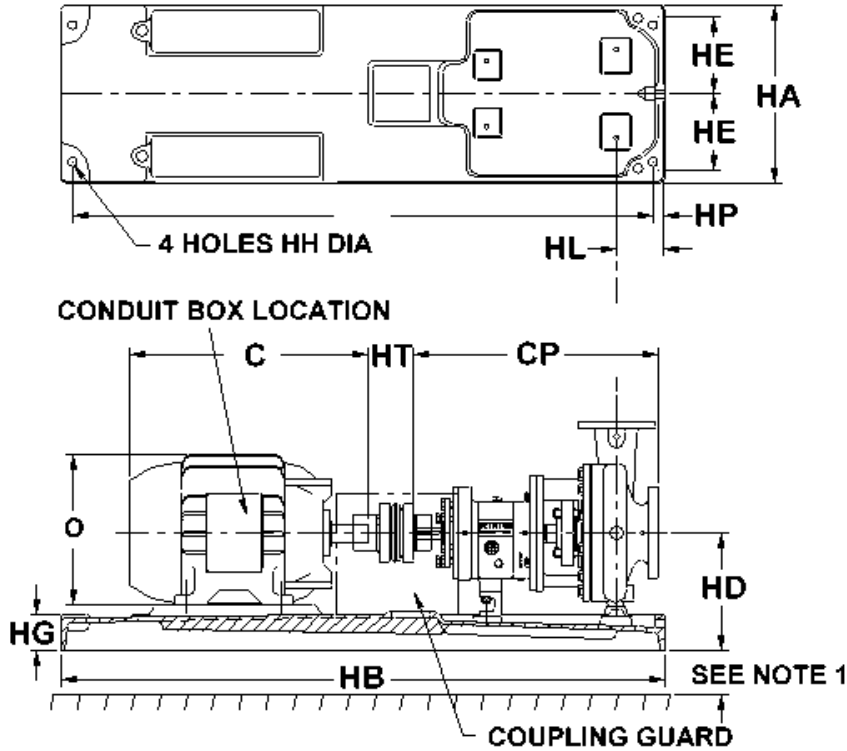

Note 1: Customer must fill base with grout and allow .75 to 1.5" grout thickness between top of foundation and bottom of base.

Note 2: Unit installation and final coupling alignment must be in accordance with Bulletin 4852840

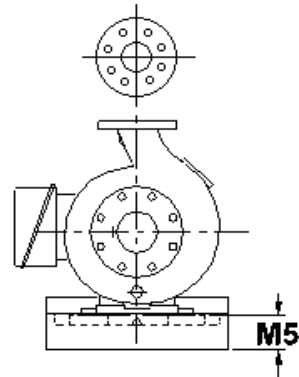

Dimensions apply only to Pump Sizes 2x3-6, 2x3-8, 3x4-8, 3x4-8G, 1x2-10, 1-1/2x2-10, 2x3-10, 3x4-10

8196 Frame Size	Base No.	Motor Frame	C Max	O Max	HA	HB	HD	HE	HF	HG	HL	HH	HP	HT	M5	Mtr Wt Lb Including Cplg	Base, Cplg Guard Wt Lb
✓ MTP & LTP	245	143T	12.69	7.50	14.25	45.00	11.88	4.50	42.50	3.25	4.50	0.75	1.25	3.75	3.62	40	219
MTP & LTP	245	145T	12.69	7.50	14.25	45.00	11.88	4.50	42.50	3.25	4.50	0.75	1.25	3.75	3.62	45	219
MTP & LTP	245	182T	15.19	9.88	14.25	45.00	11.88	4.50	42.50	3.25	4.50	0.75	1.25	3.75	3.62	65	219
MTP & LTP	245	184T	16.19	9.88	14.25	45.00	11.88	4.50	42.50	3.25	4.50	0.75	1.25	3.75	3.62	75	219
MTP & LTP	252	213T	18.56	11.25	15.25	52.00	12.25	6.00	49.50	3.50	4.50	0.75	1.25	3.75	4.00	150	246
MTP & LTP	252	215T	20.06	11.25	15.25	52.00	12.25	6.00	49.50	3.50	4.50	0.75	1.25	3.75	4.00	160	246
MTP & LTP	258	254T	24.56	13.00	18.25	58.00	12.88	7.50	55.50	4.00	4.50	1.00	1.25	3.75	4.63	255	290
MTP & LTP	258	256T	25.00	13.25	18.25	58.00	12.88	7.50	55.50	4.00	4.50	1.00	1.25	3.75	4.63	280	290
MTP & LTP	258	284T	27.44	14.75	18.25	58.00	12.88	7.50	55.50	4.00	4.50	1.00	1.25	3.75	4.63	375	290
MTP & LTP	258	284TS	26.06	14.75	18.25	58.00	12.88	7.50	55.50	4.00	4.50	1.00	1.25	3.75	4.63	345	290
MTP & LTP	258	286T	27.69	14.75	18.25	58.00	12.88	7.50	55.50	4.00	4.50	1.00	1.25	3.75	4.63	430	290
MTP & LTP	258	286TS	26.25	14.75	18.25	58.00	12.88	7.50	55.50	4.00	4.50	1.00	1.25	3.75	4.63	380	290
MTP & LTP	264	324T	30.44	16.69	19.25	64.00	13.75	7.50	61.50	4.00	4.50	1.00	1.25	3.75	5.50	575	330
MTP & LTP	264	324TS	28.94	16.69	19.25	64.00	13.75	7.50	61.50	4.00	4.50	1.00	1.25	3.75	5.50	485	330
MTP & LTP	264	326T	31.19	16.69	19.25	64.00	13.75	7.50	61.50	4.00	4.50	1.00	1.25	3.75	5.50	640	330
MTP & LTP	264	326TS	29.69	16.69	19.25	64.00	13.75	7.50	61.50	4.00	4.50	1.00	1.25	3.75	5.50	570	330
MTP & LTP	264	364T	33.44	18.50	19.25	64.00	13.75	7.50	61.50	4.00	4.50	1.00	1.25	3.75	5.50	810	330
MTP & LTP	264	364TS	31.31	18.50	19.25	64.00	13.75	7.50	61.50	4.00	4.50	1.00	1.25	3.75	5.50	755	330
MTP & LTP	264	365T	33.44	18.50	19.25	64.00	13.75	7.50	61.50	4.00	4.50	1.00	1.25	3.75	5.50	950	330
MTP & LTP	264	365TS	31.31	18.50	19.25	64.00	13.75	7.50	61.50	4.00	4.50	1.00	1.25	3.75	5.50	865	330
MTP & LTP	268	404T	38.31	21.31	22.25	68.00	14.75	9.50	65.50	4.00	4.50	1.00	1.25	3.75	6.50	1080	408
MTP & LTP	268	404TS	35.31	21.31	22.25	68.00	14.75	9.50	65.50	4.00	4.50	1.00	1.25	3.75	6.50	1080	408
MTP & LTP	268	405T	38.31	21.31	22.25	68.00	14.75	9.50	65.50	4.00	4.50	1.00	1.25	3.75	6.50	1110	408
MTP & LTP	268	405TS	35.31	21.31	22.25	68.00	14.75	9.50	65.50	4.00	4.50	1.00	1.25	3.75	6.50	1110	408

Customer _____ Purchase Order No. _____ Service _____
Pump Size _____ Material _____ Item _____
GPM _____ Total Head in Feet _____ Rpm _____ Marks _____
Motor Manufacturer _____ Enclosure _____ Motor Features _____
Hp _____ Volts _____ Phase _____ Hertz _____
By _____ Date _____ Certified for Approval Construction

All Dimensions are in inches

Drawing No. 4853920



**PROCESS PUMPS SINGLE STAGE END
SUCTION ANSI Standard Dimensions Series
8196 - MTP, LTP Frame**

Unit Dimensional Outline Cast Iron Drip Rim Base

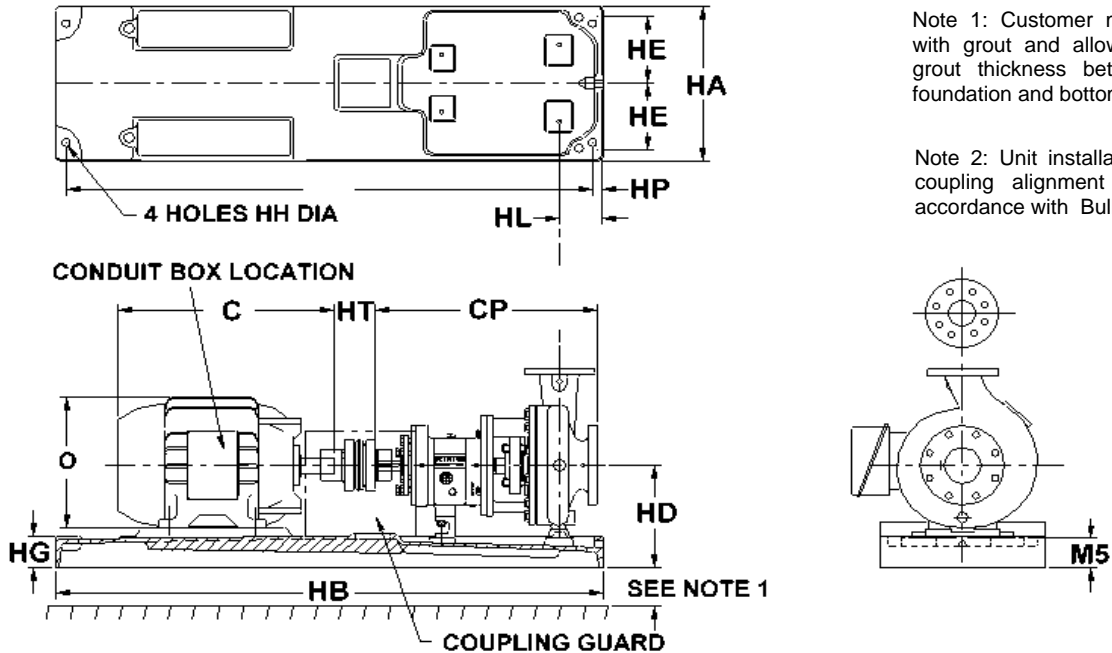

Note 1: Customer must fill base with grout and allow .75 to 1.5" grout thickness between top of foundation and bottom of base.

Note 2: Unit installation and final coupling alignment must be in accordance with Bulletin 4852840

Dimensions apply only to Pump Sizes 4x6-10, 1-1/2x3-13, 2x3-13, 3x4-13, 4x6-13

✓	8196 Frame Size	Base No.	Motor Frame	C Max	O Max	HA	HB	HD	HE	HF	HG	HL	HH	HP	HT	CP	M5	Motor Wt Lb Including Cplg	Base Cplg Guard Wt Lb
	MTP & LTP	245	182T	15.19	9.88	14.25	45.00	13.63	4.50	42.50	3.25	4.50	0.75	1.25	3.75	23.50	3.62	65	219
	MTP & LTP	245	184T	16.19	9.88	14.25	45.00	13.63	4.50	42.50	3.25	4.50	0.75	1.25	3.75	23.50	3.62	75	219
	MTP & LTP	252	213T	18.56	11.25	15.25	52.00	14.00	6.00	49.50	3.50	4.50	0.75	1.25	3.75	23.50	4.00	150	246
	MTP & LTP	252	215T	20.06	11.25	15.25	52.00	14.00	6.00	49.50	3.50	4.50	0.75	1.25	3.75	23.50	4.00	160	246
	MTP & LTP	258	254T	24.56	13.00	18.25	58.00	14.63	7.50	55.50	4.00	4.50	1.00	1.25	3.75	23.50	4.63	255	300
	MTP & LTP	258	256T	25.00	13.25	18.25	58.00	14.63	7.50	55.50	4.00	4.50	1.00	1.25	3.75	23.50	4.63	280	300
	MTP & LTP	258	284T	27.44	14.75	18.25	58.00	14.63	7.50	55.50	4.00	4.50	1.00	1.25	3.75	23.50	4.63	375	300
	MTP & LTP	258	284TS	26.06	14.75	18.25	58.00	14.63	7.50	55.50	4.00	4.50	1.00	1.25	3.75	23.50	4.63	345	300
	MTP & LTP	258	286T	27.69	14.75	18.25	58.00	14.63	7.50	55.50	4.00	4.50	1.00	1.25	3.75	23.50	4.63	430	300
	MTP & LTP	258	286TS	26.25	14.75	18.25	58.00	14.63	7.50	55.50	4.00	4.50	1.00	1.25	3.75	23.50	4.63	380	300
	MTP & LTP	264	324T	30.44	16.69	19.25	64.00	14.63	7.50	61.50	4.00	4.50	1.00	1.25	3.75	23.50	4.63	575	342
	MTP & LTP	264	324TS	28.94	16.69	19.25	64.00	14.63	7.50	61.50	4.00	4.50	1.00	1.25	3.75	23.50	4.63	485	342
	MTP & LTP	264	326T	31.19	16.69	19.25	64.00	14.63	7.50	61.50	4.00	4.50	1.00	1.25	3.75	23.50	4.63	640	342
	MTP & LTP	264	326TS	29.69	16.69	19.25	64.00	14.63	7.50	61.50	4.00	4.50	1.00	1.25	3.75	23.50	4.63	570	342
	MTP & LTP	264	364T	33.44	18.50	19.25	64.00	14.63	7.50	61.50	4.00	4.50	1.00	1.25	3.75	23.50	4.63	810	342
	MTP & LTP	264	364TS	31.31	18.50	19.25	64.00	14.63	7.50	61.50	4.00	4.50	1.00	1.25	3.75	23.50	4.63	755	342
	MTP & LTP	264	365T	33.44	18.50	19.25	64.00	14.63	7.50	61.50	4.00	4.50	1.00	1.25	3.75	23.50	4.63	950	342
	MTP & LTP	264	365TS	31.31	18.50	19.25	64.00	14.63	7.50	61.50	4.00	4.50	1.00	1.25	3.75	23.50	4.63	865	342
	MTP & LTP	268	404T	38.31	21.31	22.25	68.00	14.75	9.50	65.50	4.00	4.50	1.00	1.25	3.75	23.50	4.75	1080	412
	MTP & LTP	268	404TS	35.31	21.31	22.25	68.00	14.75	9.50	65.50	4.00	4.50	1.00	1.25	3.75	23.50	4.75	1080	412
	MTP & LTP	268	405T	38.31	21.31	22.25	68.00	14.75	9.50	65.50	4.00	4.50	1.00	1.25	3.75	23.50	4.75	1110	412
	MTP & LTP	268	405TS	35.31	21.31	22.25	68.00	14.75	9.50	65.50	4.00	4.50	1.00	1.25	3.75	23.50	4.75	1110	412
	MTP & LTP	280	444T	44.62	23.38	24.25	80.00	15.75	9.50	77.50	4.00	4.50	1.00	1.25	3.75	23.50	5.75	1500	560
	MTP & LTP	280	444TS	40.88	23.38	24.25	80.00	15.75	9.50	77.50	4.00	4.50	1.00	1.25	3.75	23.50	5.75	1500	560
	MTP & LTP	280	445T	45.88	23.38	24.25	80.00	15.75	9.50	77.50	4.00	4.50	1.00	1.25	3.75	23.50	5.75	1675	560
	MTP & LTP	280	445TS	42.13	23.38	24.25	80.00	15.75	9.50	77.50	4.00	4.50	1.00	1.25	3.75	23.50	5.75	1675	560
	MTP & LTP	280	447T	49.38	22.75	24.25	80.00	15.75	9.50	77.50	4.00	4.50	1.00	1.25	3.75	23.50	5.75	2320	560
	MTP & LTP	280	447TS	45.63	22.75	24.25	80.00	15.75	9.50	77.50	4.00	4.50	1.00	1.25	3.75	23.50	5.75	2320	560
	MTP & LTP	280	449T	55.13	24.13	24.25	80.00	15.75	9.50	77.50	4.00	4.50	1.00	1.25	3.75	23.50	5.75	2500	560
	MTP & LTP	280	449TS	51.38	24.13	24.25	80.00	15.75	9.50	77.50	4.00	4.50	1.00	1.25	3.75	23.50	5.75	2500	560

Customer _____ Purchase Order No. _____ Service _____
 Pump Size _____ Material _____ Item _____
 GPM _____ Total Head in Feet _____ Rpm _____ Marks _____
 Motor Manufacturer _____ Enclosure _____ Motor Features _____
 Hp _____ Volts _____ Phase _____ Hertz _____
 By _____ Date _____ Certified for Approval Construction
 All Dimensions are in inches Drawing No. 4853921

**PROCESS PUMPS SINGLE STAGE END
SUCTION ANSI Standard Dimensions
Series 8196 -XLTP Frame**



Peerless Pump Company
Indianapolis, IN 46207-7026

Unit Dimensional Outline Cast Iron Drip Rim Base

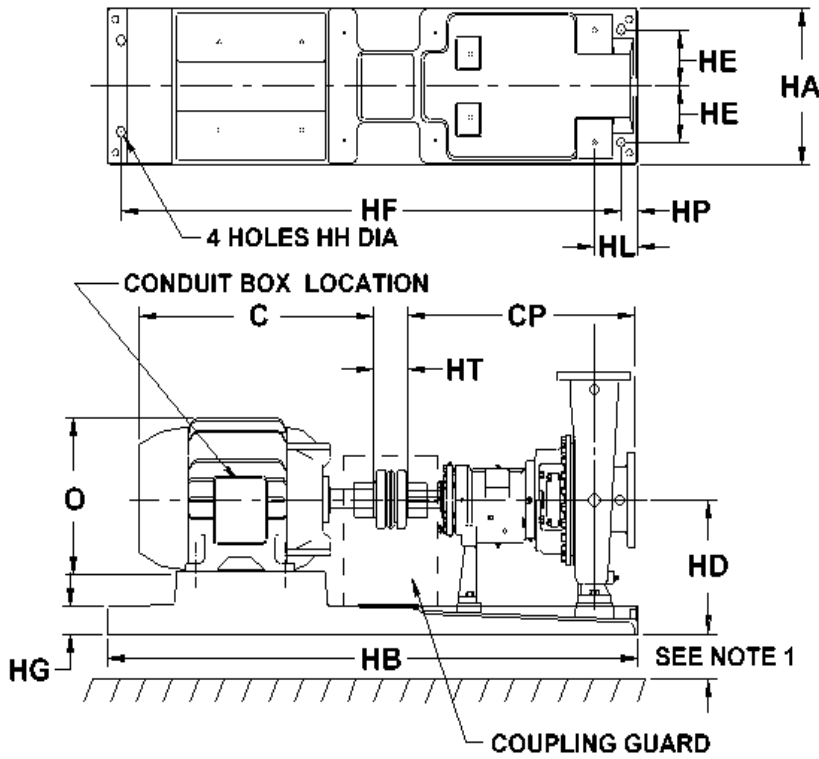

Note 1: Customer must fill base with grout and allow .75 to 1.5" grout thickness between top of foundation and bottom of base.

Note 2: Unit installation and final coupling alignment must be in accordance with Bulletin 4852840

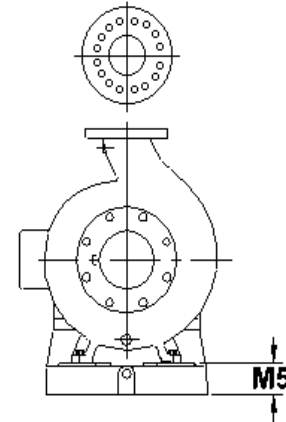

✓	8196 Frame Size	Base No.	Motor Frame	C	O	HA	HB	HD	HE	HF	HG	HL	HH	HP	HT	M5	Motor Wt Lb Including Cplg	Base, Cplg, Guard Wt Lb
	XLTP	368	284T	27.44	14.75	24.25	68.00	19.00	9.50	65.50	4.00	6.50	1.00	1.25	5.25	4.50	410	564
	XLTP	368	284TS	26.06	14.75	24.25	68.00	19.00	9.50	65.50	4.00	6.50	1.00	1.25	5.25	4.50	380	564
	XLTP	368	286T	27.69	14.75	24.25	68.00	19.00	9.50	65.50	4.00	6.50	1.00	1.25	5.25	4.50	445	564
	XLTP	368	286TS	26.25	14.75	24.25	68.00	19.00	9.50	65.50	4.00	6.50	1.00	1.25	5.25	4.50	435	564
	XLTP	380	324T	30.44	16.69	24.25	80.00	19.00	9.50	77.50	4.00	6.50	1.00	1.25	5.25	4.50	560	668
	XLTP	380	324TS	28.94	16.69	24.25	80.00	19.00	9.50	77.50	4.00	6.50	1.00	1.25	5.25	4.50	540	668
	XLTP	380	326T	31.19	16.69	24.25	80.00	19.00	9.50	77.50	4.00	6.50	1.00	1.25	5.25	4.50	620	668
	XLTP	380	326TS	29.69	16.69	24.25	80.00	19.00	9.50	77.50	4.00	6.50	1.00	1.25	5.25	4.50	600	668
	XLTP	380	364T	33.44	18.50	24.25	80.00	19.00	9.50	77.50	4.00	6.50	1.00	1.25	5.25	4.50	795	668
	XLTP	380	364TS	31.31	18.50	24.25	80.00	19.00	9.50	77.50	4.00	6.50	1.00	1.25	5.25	4.50	780	668
	XLTP	380	365T	33.44	18.50	24.25	80.00	19.00	9.50	77.50	4.00	6.50	1.00	1.25	5.25	4.50	880	668
	XLTP	380	365TS	31.31	18.50	24.25	80.00	19.00	9.50	77.50	4.00	6.50	1.00	1.25	5.25	4.50	865	668
	XLTP	380	404T	38.31	21.31	24.25	80.00	19.00	9.50	77.50	4.00	6.50	1.00	1.25	5.25	4.50	1105	668
	XLTP	380	404TS	35.31	21.31	24.25	80.00	19.00	9.50	77.50	4.00	6.50	1.00	1.25	5.25	4.50	1105	668
	XLTP	380	405T	38.31	21.31	24.25	80.00	19.00	9.50	77.50	4.00	6.50	1.00	1.25	5.25	4.50	1215	668
	XLTP	380	405TS	35.31	21.31	24.25	80.00	19.00	9.50	77.50	4.00	6.50	1.00	1.25	5.25	4.50	1215	668
	XLTP	398	444T	44.62	23.38	26.25	98.00	19.00	9.50	95.50	4.00	6.50	1.00	1.25	5.25	4.50	1500	920
	XLTP	398	444TS	40.88	23.38	26.25	98.00	19.00	9.50	95.50	4.00	6.50	1.00	1.25	5.25	4.50	1500	920
	XLTP	398	445T	45.88	23.38	26.25	98.00	19.00	9.50	95.50	4.00	6.50	1.00	1.25	5.25	4.50	1710	920
	XLTP	398	445TS	42.13	23.38	26.25	98.00	19.00	9.50	95.50	4.00	6.50	1.00	1.25	5.25	4.50	1710	920
	XLTP	398	447T	49.38	22.75	26.25	98.00	19.00	9.50	95.50	4.00	6.50	1.00	1.25	5.25	4.50	2320	920
	XLTP	398	447TS	45.63	22.75	26.25	98.00	19.00	9.50	95.50	4.00	6.50	1.00	1.25	5.25	4.50	2320	920
	XLTP	398	449T	55.13	24.13	26.25	98.00	19.00	9.50	95.50	4.00	6.50	1.00	1.25	5.25	4.50	2500	920
	XLTP	398	449TS	51.38	24.13	26.25	98.00	19.00	9.50	95.50	4.00	6.50	1.00	1.25	5.25	4.50	2500	920

Customer _____ Purchase Order No. _____ Service _____
Pump Size _____ Material _____ Item _____
GPM _____ Total Head in Feet _____ Rpm _____ Marks _____
Motor Manufacturer _____ Enclosure _____ Motor Features _____
Hp _____ Volts _____ Phase _____ Hertz _____
By _____ Date _____ Certified for Approval Construction

All Dimensions are in inches

Drawing No. 4853922