

Non-clog submersible sewage pump Type UW

Instructions

- Installation
- Operation
- Maintenance

Read this entire book

before attempting to install, operate or repair this pump. Properly installed, your Peerless Pump Sewage Pump will give you satisfactory, dependable service. We urge that you read carefully these step-by-step instructions, to simplify any problems of installation, operation or repair.

Failure to read and comply with installation and operating instructions will void the responsibility of

the manufacturer and may also result in bodily injury as well as property damage.

This book is intended to be a permanent part of your installation and should be preserved in a convenient location for ready reference. If these instructions should become soiled, obtain a new copy from Peerless. Include pump model and/or serial number with your request.

WARRANTY

New equipment manufactured by Seller is warranted to be free from defects in material and workmanship under normal use and service for a period of one year from date of shipment; Seller's obligation under this warranty being limited to repairing or replacing at its option any part found to its satisfaction to be so defective provided that such part is, upon request, returned to Seller's factory from which it was shipped, transportation prepaid. This warranty does not cover parts damaged by decomposition from chemical action or wear caused by abrasive materials, nor does it cover damage resulting from misuse, accident, neglect, or from improper operation, maintenance, installation, modification or adjustment. This warranty does not cover parts repaired outside the Seller's factory without prior written approval. Seller makes no warranty as to starting equipment, electrical apparatus or other material not of its manufacture, since the same are usually covered by warranties of the respective manufacturers thereof.

In the event, notwithstanding the terms of this agreement, it is determined by a court of competent jurisdiction that an express warranty has been given by Seller to Purchaser with respect to the head, capacity or other like performance characteristics of said equipment, Seller's liability for breach of the same shall be limited to accepting return of such equipment F.O.B. plant of manufacture, refunding any amount paid thereon by Purchaser (less depreciation at the rate of 15% per year if Purchaser has used the equipment for more than thirty (30) days) and canceling any balance still owing on the equipment.

THIS WARRANTY IS EXPRESSLY IN LIEU OF ANY OTHER WARRANTIES, EXPRESSED OR IMPLIED, AND SELLER SPECIFICALLY DISCLAIMS ANY IMPLIED WARRANTY OF MERCHANTABILITY OR FITNESS FOR A PARTICULAR PURPOSE.



Peerless Pump Company
Indianapolis IN, 46207-7026

2899213
REV 4-79

IMPORTANT SAFETY PRECAUTIONS

Pump parts, and the tools and rigging equipment used in installation, are heavy and may easily cause personal injury if dropped or carelessly handled. The normal precautions and safety rules associated with the erection of heavy machinery, in regard to manual lifting, use of power equipment, and handling of tools, must be observed in the installation of this pump.

Petroleum-base cleaning solvents are flammable. Open flame or smoking by personnel in the vicinity of these solvents is extremely hazardous and must not be permitted.

Do not work under a suspended object unless there is a positive support under it to stop its fall in event of sling or hoist failure. Disregard of this warning could result in grave personal injury.

Before attempting repairs to pump open the disconnect switch to electric motor. This prevents accidental running of pump motor. Starting motor during pump repair activities could damage pump

and may cause personal injury.

Disconnect power supply before attempting to change connections in the starter. There is danger of fatal electrical shock when working with energized connections.

Disconnect the power supply before removing the motor connection chamber to change connection. There is danger of fatal electrical shock when working with energized leads.

Do not use motor electrical cable to lift or lower sewage pump. Use the pump lugs provided to attach sling or cable for lifting and lowering pump into basin. Electrical cable strains may cause equipment malfunction, damage, and personal injury or death.

Tie the disconnect switch open or remove fuses from lines before attempting to remove pump from the basin. Attach a card "DO NOT CLOSE SWITCH-PUMP REPAIR IN PROGRESS." Disregard of this warning may result in fatal electrical shock.

WARNING

The pumps described in this bulletin must not be installed in any manner except as specified herein, and must not be operated at speeds, capacities, pressures, or temperatures other than those for which this specific model was originally designed. If unsure or unknown, request this information from Peerless Pump, giving the pump serial number as reference.

Units are designed for continuous duty submerged in liquids containing a maximum solid content 10% by weight to 90% liquid normally encountered in sewage lift or sump pump applications and limited to corrosion limits of standard materials of construction. 40 dC [105dF] maximum liquid temperature. Motors less than 1 hp. Labeled CI. 1 Group D are supplied with a cautionary nameplate and are suitable only when vapor or gas ignition temperatures are 280dC or greater.

All units must be provided with a magnetic across-the-line motor starter. The motor thermal protector must be wired in series with the pump liquid level controller and starter contactor holding coil for motor warranty to be valid.

The motor thermal protectors are limited to control circuits in which the maximum current does not exceed the following values.

Volts	Amps	Inrush Amps
110-220	3.00	30.0
220-240	1.50	15.0
440-480	.75	7.5
575	.60	6.0

Violation of this warning will void the warranty and may result in serious property damage or grave personal injury.

INTRODUCTION

UPON RECEIPT OF SEWAGE PUMP: Check carefully to see that all of the equipment has been received. Report immediately any shortages or damages to the transportation company handling the shipment, noting the extent of the damage or shortage on the freight bill and bill of lading. Do not leave the unit exposed to weather or construction hazards. The pump may become mechanically damaged. This pump is a well designed and carefully manufactured

unit. It should be given the same attention accorded to any precision machine.

The satisfactory operation of a pump depends to a large extent upon proper installation. These instructions cannot answer every question that may arise as each installation will be different. The installer and the operator of this equipment must use good judgment to adapt these procedures to the installation.

INSTALLATION

WARNING Do not work under a heavy, suspended object unless there is a positive support under it to stop its fall in event of sling or hoist failure. Disregard of this warning could result in grave, personal injury.

LOCATION: Install the sewage pump where it will be accessible for inspection and maintenance. Observe the following:

Locate the receiver (basin) and pump so that the liquid flows into the basin by gravity.

Install basin so that the floor plate (basin cover) is not below floor level. If below floor level, water may collect on the cover.

SETTING BASIN: Dig a pit of sufficient depth and diameter to accommodate the basin and pipe connections.

Note the following:

1. If pit bottom is soft or soggy, prepare a gravel or concrete slab (or equivalent bed) to support basin.

2. Set the basin on the bed, if necessary, level basin with wedges or shims.

3. Fill the space around the basin with firmly tamped gravel, or similar material. After which the concrete floor may be poured or patched around the basin.

BASIN COVER: The basin cover fits over the basin and may be set into concrete flush to floor level, or bolted to a curbing. Basin cover may also be fastened to the flange of a fiberglass, cast iron or steel basin.

For gastight installations use a gasket or non-hardening sealing compound to seal cover to basin or curbing. Set the basin cover on the basin, locating discharge opening(s) as required. Consider the position of the openings provided for the float controls in order that the float is not disturbed by strong water currents and the moving element is able to rise and fall freely. Secure cover the basin by tightening fasteners.

Note: Some covers have manholes large enough to allow installation and removal of pump unit. This type cover is to be completely secured to basin. Other covers have a removable section. Do not secure removable section until pump unit(s) has been installed.

CAUTION The pump impeller must rotate in the Direction shown by the arrow on the discharge casing. When checking for proper rotation prior to installing pump, do not run for a long period as the motor is not suitable for prolonged operation in air.

MOTOR ROTATION: Prior to setting the pump in the basin check the direction of rotation of the motor as follows:

1. Three Phase Motors:

- Temporarily connect motor leads to power source.
- Momentarily energize motor to just start turning.
- Observe that impeller rotation is in direction of arrow on discharge casing.

WARNING Disconnect power supply before attempting to change connections in the starter. There is danger of fatal electrical shock when working with energized connections.

- If rotation is not correct, interchange any 2 leads at the starter. Reconnect power and repeat step b to check rotation again.
- Disconnect power supply.
- Mark the leads and power supply to identify for permanent connection later.

2. Single Phase Motors:

- Temporarily connect motor to power source as shown in diagram on motor nameplate.
- Momentarily energize motor to just start turning.
- Observe that impeller rotates in correct direction.

WARNING Disconnect the power supply before removing the motor connection chamber to change connection. There is danger of fatal electrical shock when working with energized leads.

- Use care when removing motor connection chamber to prevent damage to O-ring. After changing connections, carefully reassembly motor connection chamber.
- Reconnect power supply and repeat step B to check rotation again.
- Disconnect power supply.

PUMP INSTALLATION: Flush the drainage system with water and clean the basin. Foreign material occasionally found in new systems could damage the pump if not removed.

WARNING Do not use motor electrical cable to lift or lower sewage pump. Use the pump lugs provided to attach sling or cable for lifting and lowering pump into basin. Electrical cable strains may cause equipment malfunction, damage, and personal injury or death.

- With cable or sling attached to the pump lugs and a hoist of proper capacity, slowly lower the pump through the opening in the basin cover.
- Locate pump on basin floor so that pump discharge is aligned with discharge opening in basin cover (see figure 1).

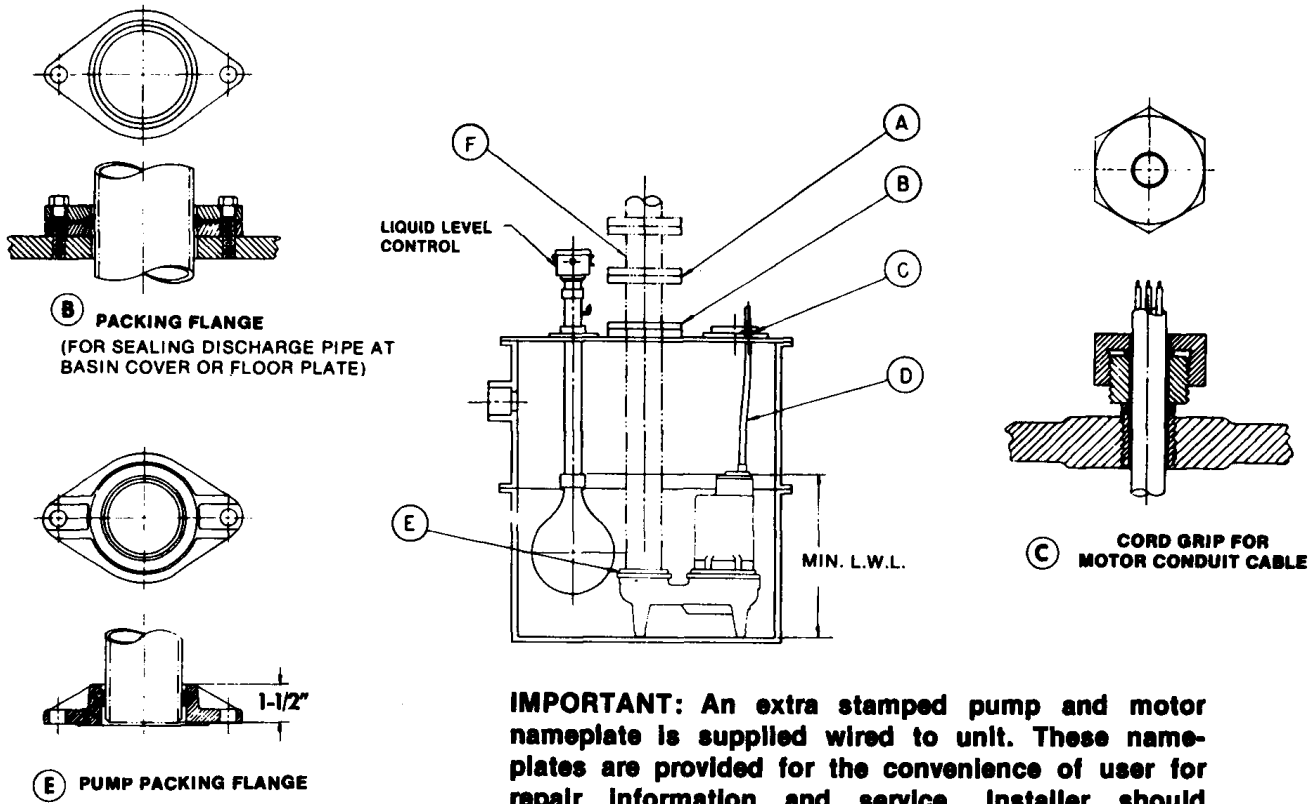

IMPORTANT: An extra stamped pump and motor nameplate is supplied wired to unit. These nameplates are provided for the convenience of user for repair information and service. Installer should permanently affix them to basin cover or some convenient location for ready reference by user.

- | | |
|-------------------------|-------------------|
| A. Discharge pipe | D. Motor cable |
| B. Cover packing flange | E. Packing flange |
| C. Motor cable grip | F. Spool piece |

Figure 1. Installing Sewage Pump in Basin

3. Break sharp, outside edge of discharge pipe with a file. A rounded corner is preferred, but a smooth chamfer should be acceptable.
4. Apply light oil to pump packing flange (E), cover packing flange (B) and outside entire length of discharge pipe (A) which will pass through the cover packing.
5. Insert discharge pipe through cover flange, lower pipe until end rests on pump flange (E).
6. Scribe a line on pipe OD at cover flange (B) scribe a second line 1-1/2 inches above the first line.
7. With a downward turning, twisting motion insert the pipe into pump flange (E) until the second line (step 6) reaches the cover flange.
8. Tighten cover flange bolts until discharge pipe is securely held by packing forced against pipe OD.
9. It is recommended that a spool piece (F) be installed in the discharge pipe above the basin cover for ease of assembly and disassembly.
10. Loosen the cord grips (C). Pull motor cables (D) through the cord grips leaving a little slack and tighten grips to hold cables. Route cables to motor control panel (through conduit, if required).

11. Seal the basin cover split (if 2-piece basin cover was supplied), manhole cover and discharge pipe flanges with a pliable, non-hardening sealer (available at any plumbing supply).

PIPING: The discharge pipe line of the pump should include a union, a horizontal swing check valve, and a gate valve, all near the pump.

The line should be run to a point above the sewer level so as to drop into the sewer from above. This arrangement permits easy removal of the unit for repairs and cleaning and prevents sewer backing up through the discharge pipe.

The discharge pipe should not be smaller in size than the discharge connection on the pump. Where runs are long, they should be at least one or two sizes larger.

It is important that the pipe connections to the unit be so made that there is no pipe strain upon the pump.

When raw swage is handled, the basin should be vented to the atmosphere.

LIQUID LEVEL CONTROLS: Peerless Pump offers fixed or sliding float versions of standard float controls, or, a sealed electrode floatless controller,

called Sealtrode. Your installation may be furnished with any of these according to original purchase specifications.

FLOAT CONTROL: The float control (when furnished) is a type of liquid level control which provides automatic operation of the pump unit.

On liquid level rise the float raises the float rod with its fixed buttons until the lower button trips the float switch, starting the pump. As the liquid level drops, the upper float button trips the switch to the off position, stopping the pump.

INSTALLING AND REGULATING THE STANDARD FLOAT CONTROL: Locate the float mechanism where provided for on the basin cover. The usual float switch equipment consists of a float rod, float, guide pipe for float rod, switch stand assembly and float rod adjusting buttons. The specific arrangement for the C84A fixed float system or the C93A sliding float system must be taken from the instructions furnished with your float control.

CAUTION When adjusting the setting of the low water cut-out level for any liquid level control be sure that the liquid surface at pump cut-out is above the top of the motor [see figure 1]. The motor is designed to operate submerged and relies upon the liquid in which it is submerged to act as its coolant. The temperature of the liquid being pumped is not to exceed 105dF [40dC] to insure proper cooling of the motor.

PUMP ALTERATION FOR DUPLEX UNITS: When the pumping unit consists of two pumps in a common basin it is desirable to provide automatic alternation of the pumps to insure equal wear and allow for extra heavy periodic flow handling capability.

Alternating control provides alternate operation of the two pumping units on successive cycles as long as a single pump can handle the pump load. However, under peak flow conditions, when the liquid level continues to rise more rapidly than can be handled by one pump, both units are automatically placed in operation.

ALTERNATING TYPE FLOAT SWITCH: The alternating type float switch consists of two 2 pole float switches in a single enclosure. The float switches are mechanically connected through linkage which causes

alternate operation of the two pumping units. The switch is controlled by the float which actuates the switch on rise and fall of the liquid level. The action is such that the two switches are alternated on successive cycles. If the liquid level continues to rise with one pump in operation, the switch lever arm will continue to travel upward to a further position will continue to travel upward to a further position at which point the "second" switch will operate, starting the standby pump. The switch is illustrated in figure 2.

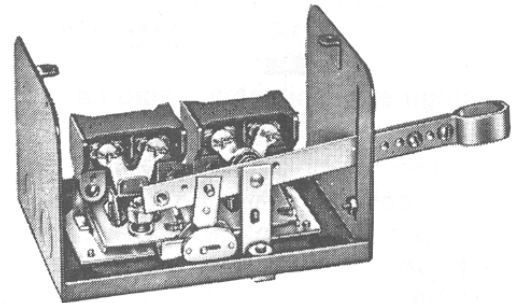

Figure 2. Alternating Switch

CONTROLS: It is recommended that a suitable overload protector, or an across-the-line magnetic starter be installed in the motor circuit to prevent motor burn-outs if for some reason an overload should occur. A float switch must not be used as the primary starting device in 3-phase installations. It is always used to pilot a magnetic starter. Some 1-phase installations also must employ the float switch as a pilot device only. Check the horsepower and voltage limit of the switch nameplate before wiring to decide its proper use in a 1-phase circuit.

FUSES: It is recommended that Fusetron (dual element) fuses be used if not other thermal or motor protecting device is used. The Fusetron provides for motor protection against burn-out. Care must be taken in selecting the proper size Fusetron. When a fuse blows it indicates that something is wrong, either in the motor, pump, switch, fuse rating or service. Do not replace a fuse until you find and remove the cause of the blow-out.

WIRING IMPORTANT: Connect the electric service to the controls and make inter control electrical connections when necessary according to wiring instructions accompanying the switches and motor, using conduit and wire sizes as required by local codes. Typical wiring diagrams are illustrated in figures 4 thru 7. Be sure the current characteristics of voltage and frequency indicated on motor nameplates are the same as those of the service provided.

LUBRICATION

MOTOR LUBRICATION: No motor bearing lubrication necessary. Motor bearings are sealed for life of unit.

PUMP LUBRICATION, FLOAT ROD SEAL: Before starting pump and at weekly intervals thereafter, saturate the felt washer with SAE 30 oil.

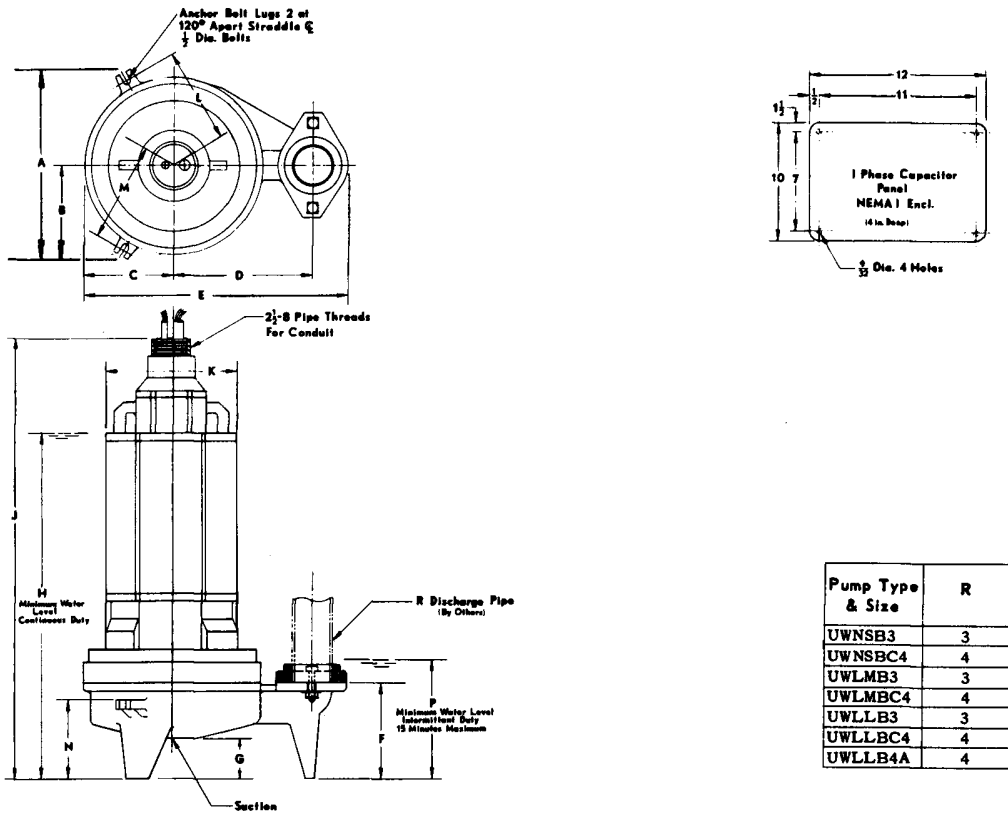

Pump Type and Size	Motor Frame Body	Motor Frame Mtg Flg	UNIT DIMENSIONS 1 PHASE													Wt Lbs	
			A	B	C	D	E	F	G	H	J	K	L	M	N		P
UWNSB3	140TY	140TY	↑	↑	↑	10-3/4	↑	↑	2-1/2	23-3/4	31-1/2	8	↑	↑	↑	↑	240
UWNSBC4	180TY	140TY	12-1/8	5-3/4	5-1/4	↑	19	6-3/4	↑	25-1/2	32-5/8	9-5/8	6-5/8	5-3/4	5-1/2	10	285
	210TY	180TY	↓	↓	↓	↑	↓	↓	↑	29-1/4	37-1/2	11-1/2	↓	↓	↓	↓	391
UWLMB3	140TY	140TY	↑	↑	↑	↓	↑	↑	↓	25-1/2	33-3/4	8	↑	↑	↑	↑	258
UWLMBC4	180TY	140TY	13-3/4	6-5/8	6-1/8	↓	20	8	↓	26-3/4	33-7/8	9-5/8	7-1/8	6-5/8	6-1/2	11	305
	210TY	180TY	↓	↓	↓	10-3/4	↓	↓	↑	30-1/2	38-3/4	11-1/2	↓	↓	↓	↓	409
UWLLB3	140TY	140TY	↑	7-3/4	↑	12	↑	↑	3-1/2	25-7/8	32-7/8	8	8-3/4	8	6-5/16	12	302
UWLLBC4	180TY	140TY	↓	↑	↑	↑	22-3/4	8-1/2	↑	27	34-1/8	9-5/8	↑	↑	↑	↑	349
	210TY	180TY	16	↓	7-5/8	↑	↓	↓	↑	34	39-1/4	11-1/2	↑	↑	↓	↓	453
	210TY	210TY	↓	↓	↓	↑	↓	↓	↑	34	39-1/4	11-1/2	↑	↑	6-5/16	12	453
UWLMB4A	140TY	140TY	↑	↑	↑	↓	↑	↑	↓	26-3/4	34-1/2	8	↓	↓	7-3/16	↑	318
	180TY	140TY	↓	↓	↓	↓	↓	↓	↑	28-1/2	35-5/8	9-5/8	↓	↓	↑	↑	365
	180TY	140TY	16-1/2	↓	8	↓	23	10-1/16	↓	35-5/8	40-3/4	11-1/2	↓	↓	↑	↑	469
	210TY	180TY	↓	7-3/4	↓	12	↓	↓	3-1/2	35-5/8	40-3/4	11-1/2	8-3/4	8	7-3/16	13	469

Pump Type and Size	Motor Frame	UNIT DIMENSIONS 3 PHASE													Wt Lbs	
		A	B	C	D	E	F	G	H	J	K	L	M	N		P
UWNSB3	140TY	↑	↑	↑	10-3/4	↑	↑	2-1/2	23-3/4	31-1/2	8	↑	↑	↑	↑	240
UWNSBC4	180TY	12-1/8	5-3/4	5-1/4	↑	19	6-3/4	↑	25-1/2	32-5/8	9-5/8	6-5/8	5-3/4	5-1/2	10	287
UWLMB3	140TY	↑	↑	↑	↓	20	8	↓	25-1/2	33-3/4	8	↑	↑	↑	↑	258
UWLMBC4	180TY	13-3/4	6-5/8	6-1/8	10-3/4	↓	↓	↑	26-3/4	33-7/8	9-5/8	7-1/8	6-5/8	6-1/2	11	305
UWLLB3	140TY	↑	7-3/4	↑	12	↑	↑	3-1/2	25-7/8	32-7/8	8	8-3/4	8	↑	↑	302
UWLLBC4	180TY	16	↓	7-5/8	↑	22-3/4	8-1/2	↑	27	34-1/8	9-5/8	↑	↑	6-5/16	12	349
	210TY	↓	↓	↓	↑	↓	↓	↑	34	39-1/4	11-1/2	↑	↑	↓	↓	453
UWLMB4A	140TY	↑	↑	↑	↓	↑	↑	↓	26-3/4	34-1/2	8	↓	↓	↑	↑	318
	180TY	16-1/2	↓	8	↓	23	10-1/16	↓	28-1/2	35-5/8	9-5/8	↓	↓	7-3/16	13	365
	210TY	↓	7-3/4	↓	12	↓	↓	3-1/2	35-5/8	40-3/4	11-1/2	8-3/4	8	7-3/16	13	469

Figure 3. Installation Dimensions

OPERATION

BEFORE STARTING, CHECK THE FOLLOWING ITEMS:

1. See that voltage and frequency on motor nameplate are the same as service provided.
2. If motors are of the dual voltage type, be sure motor leads are wired for the voltage used.
3. See that the proper fuses are installed.
4. See that switches are regulated for operation and that thermal units are "set."

STARTING: Close the discharge gate valve and the motor disconnect switch. The pump will not operate unless the liquid level pilot circuit is closed. If a selector switch is used, the pump may be run independent of automatic controls by turning it to "on" or manual position.

AFTER STARTING: Note the following:

1. Slowly open the discharge gate valve.
2. Note operation of the control mechanism. Observe several complete start-stop cycles of the unit. See that pump control switch contacts close and open properly as basin fills and is emptied by the pump. The operation of the unit should be absolutely automatic.
3. See that all pipe connections are tight.
4. Observe operation of pump closely for the first day and at regular intervals for ten days. A new machine is frequently stiff and tight, and therefore the unit should be watched to note performance.

MAINTENANCE

WARNING Read the list of important Safety Precautions provided near the front of this bulletin. The safety steps in that list must be applied during maintenance procedures. Failure to do so may lead to severe equipment damage and personal injury or death.

TROUBLESHOOTING: The following troubles may occur. To correct trouble check for the possible causes given.

1. Pump Fails to Operate:
 - a. A blown fuse, tripped or loose thermal unit.
 - b. Shaft binding or impeller blocked.
 - c. Switch contacts corroded, circuit shorted, or terminal connections broken somewhere in circuit.
 - d. Pump control mechanism not functioning, or float waterlogged.
 - e. Wiring hook-up or service provided incorrect, or switches not "set" for operation.
 - f. Motor grounded or burned.
 - g. Electric service of phase failure.
 - h. Float rod buttons improperly adjusted or slipping.
2. Blown Fuse, Tripped Thermal Unit:
 - a. Fuse of thermal unit used of incorrect rating.
 - b. Shaft stuck or not rotating freely.
 - c. Loose connection somewhere in circuit.
 - d. Controls won of arcing.
 - e. Motor grounded or partially burned out.
 - f. Motor overloading.
 - g. Fuse or thermal unit location too hot.
 - h. Short circuit in wiring.
 - i. Discharge head is lower than anticipated.
3. Pump Runs Continuously:
 - a. Check pump rotation.
 - b. See if check valve in discharge line is stuck.

- c. Check discharge head, see if beyond pump rating.
- d. Check influent rate to basin; see if inflow is excessive.
- e. See if shaft in intact and if the impeller rotates.
- f. Check to see if pump is air bound.
- g. Check float and float switch assembly.

WARNING Tie the disconnect switch open or remove fuses from lines before attempting to remove pump from the basin. Attach a card "DO NOT CLOSE SWITCH-PUMP REPAIR IN PROGRESS." Disregard of this warning may result in fatal electrical shock.

REMOVAL: Remove the sewage pump in the following manner (see figure 1):

1. Shut off or blank the influent line.
2. Close the gate valve in the discharge line.
3. Open the disconnect switch at power supply. Tie switch open and attach card to prevent closing accidentally.
4. Remove spool piece (F).
5. Loosen bolts of cover packing flange (B).
6. With an upward, twisting motion pull discharge pipe (A) from the pump flange (E) to give clearance for moving pump.
7. Tighten cover flange bolts to hold discharge pipe.
8. Tag leads for connection at reinstallation and disconnect motor cables. Loosen motor cable grips (C) and pull motor cables from cover.
9. Attach cable or sling to pump lugs and lift pump from basin with a hoist of proper capacity.

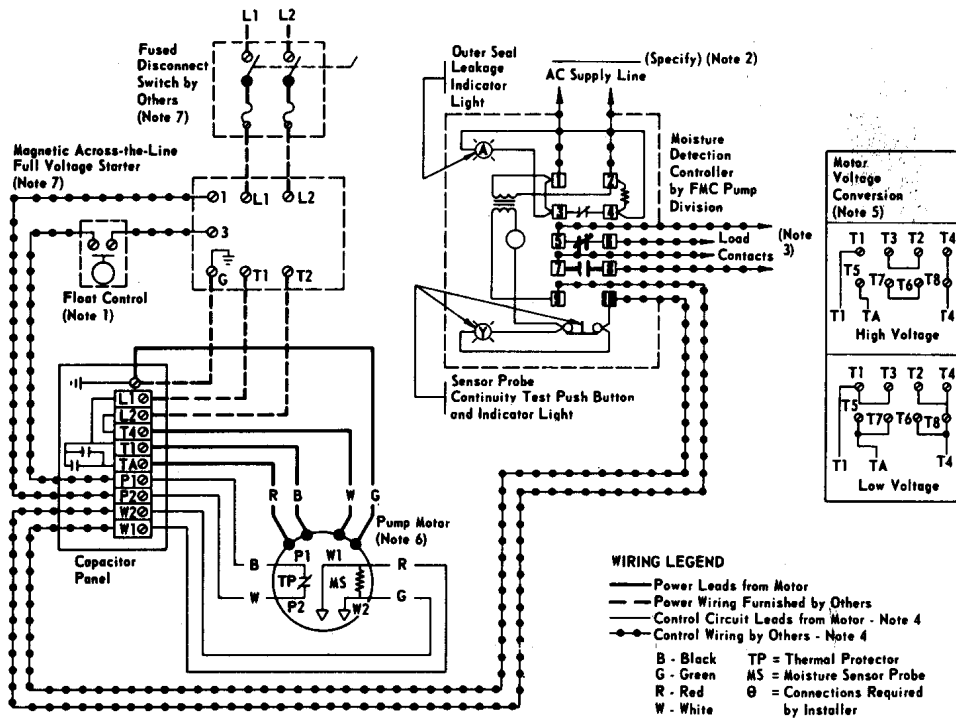

Figure 4. Single Phase Wiring Diagram, C84A or C93A Float Controls

NOTES:

1. Float Control must be wired in series with P1 & P2 and set to open circuit when liquid level drops no lower than minimums shown on pump dimension drawings.
2. Connect to A.C. supply line of voltage required. All wiring must be in accordance with N.E.C. and/or local electrical codes.
3. Connect terminals 7 & 8 to remote alarm device (by others). Terminals 5 & 6 can be wired in series with float control to shut pump down if moisture is detected.
4. Combined length of control circuit leads and control wiring to moisture detection control must not exceed 100 feet.

5. Motors are furnished by factory with motor leads connected for specified voltage. If it is necessary for voltage to be changed in the field reconnect terminals in motor terminal head in accordance with conversion diagrams. Splices must be watertight (see motor instructions for further information).
6. The motor warranty is valid only if moisture detection and thermal protection system is connected and operable. Failure to utilize these voids warranty.
7. Connections to motor starter and disconnect switch are typical only. All equipment furnished by others is to be in accordance with N.E.C. and/or local electrical codes.

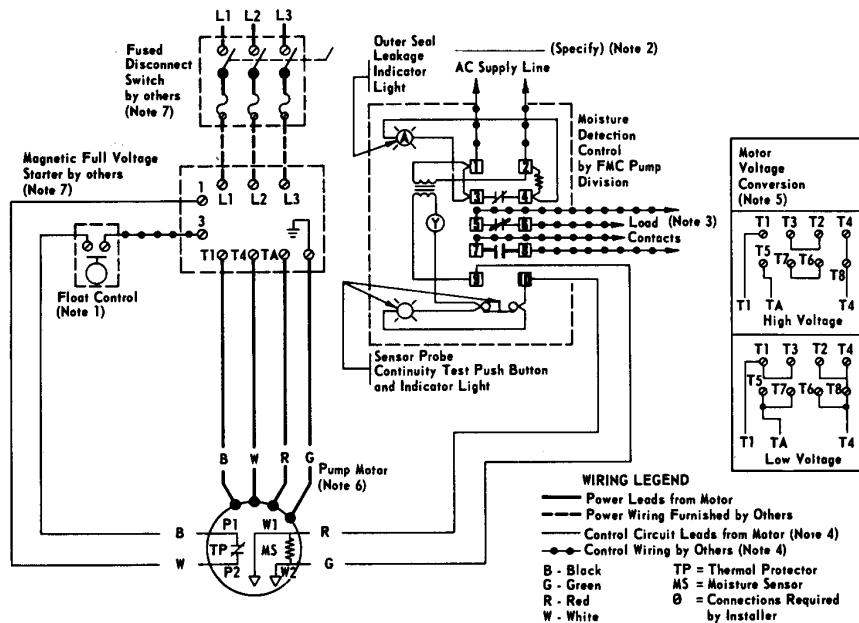

Figure 5. Three Phase Wiring Diagram, C84A or C93A Float Controls

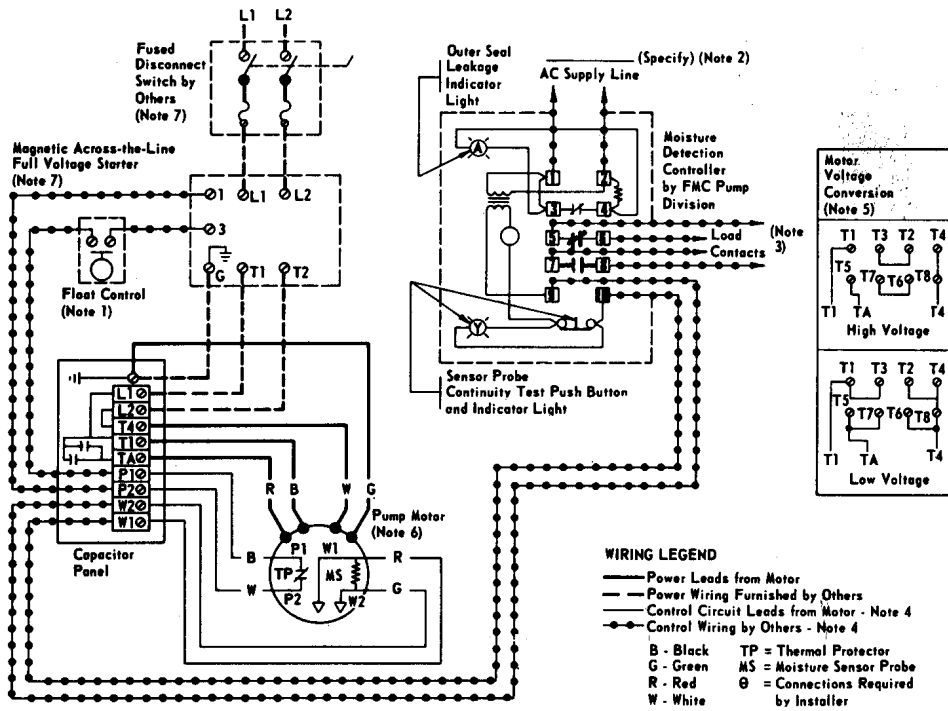

Figure 6. Single Phase Wiring Diagram, Pilot Sealrode Controllers

NOTES:

1. Connect to terminals P1 & P2 in simplex pilot Sealrode controller. Connect to respective pairs of terminals P1, P2 & P3, P4 in duplex pilot Sealrode controllers.
2. Connect to terminals 3 & 4 in simplex pilot Sealrode controllers. Connect to respective pairs of terminals 3, 4 & 5, 6 in duplex pilot Sealrode controller.
3. Connect to terminals W1 & W3 in simplex pilot Sealrode controller. Connect respective pairs of terminals W1, W2 & W3, W4 in duplex pilot Sealrode controllers.
4. Combined length of control circuit leads and control wiring to moisture detection control in pilot controller must not exceed 100 feet.

5. Motors are furnished by factory with motor lead connected for specified voltage. If it is necessary for voltage to be changed in the field reconnect terminals in motor terminal head in accordance with conversion diagrams. Splices must be watertight (see motor instructions for further information).
 6. The motor warranty is valid only if moisture detection and thermal protection system is connected and operable. Failure to utilize these voids warranty.
 7. Connections to motor starter and disconnect with are typical only. All equipment furnished by others is to be in accordance with N.E.C. and/or local electrical codes.
- GENERAL: See Pilot Sealrode Controller Wiring Diagrams for further details.

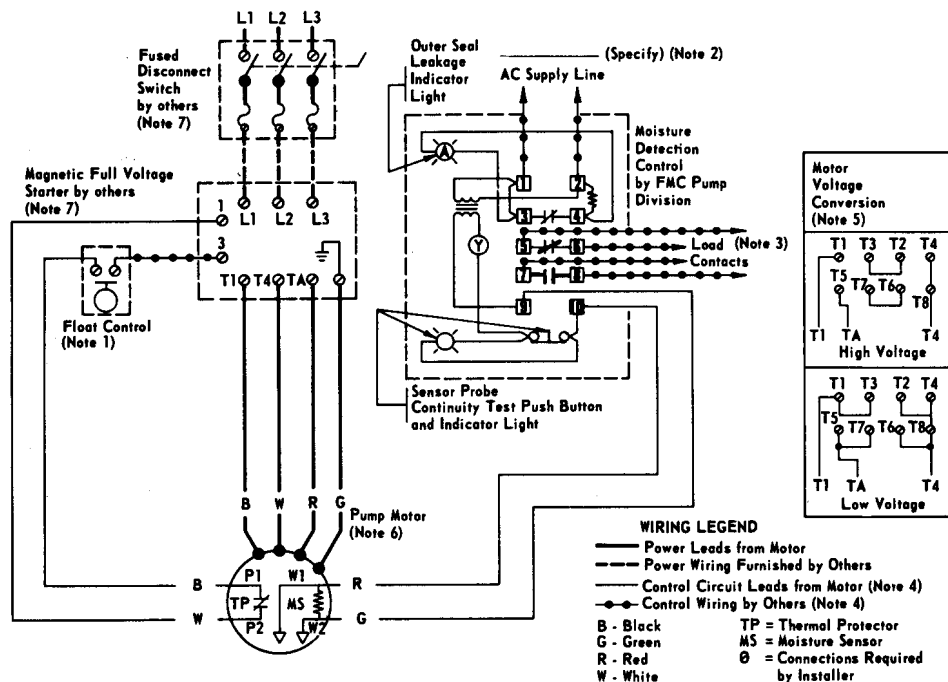

Figure 7. Three Phase Wiring Diagram, Pilot Sealrode Controllers

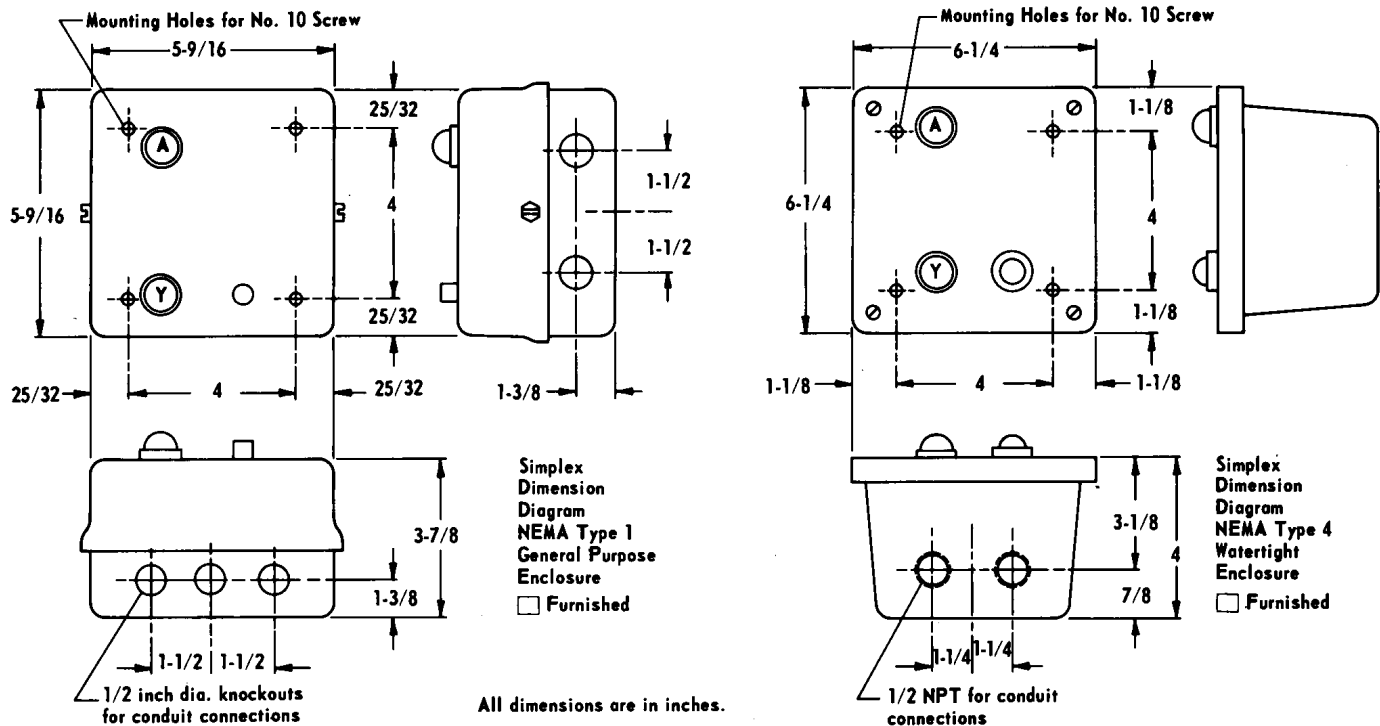

Figure 8. Simplex Moisture Detection Controller

INSTALLATION, OPERATION AND MAINTENANCE INSTRUCTIONS FOR MOISTURE DETECTION CONTROLLER

General

The Moisture Detection Controller is a conductance actuated control for detecting moisture in the oil chamber of a submersible pump motor. It is used as a warning device to indicate a seal leakage and to signal the need for preventative maintenance.

Installation

Mount control box vertically on wall or other solid structure and accomplish all indicated wiring. Terminals on the control are numbered and are in the same relative position as shown on the wiring diagram. Terminal pair 1-2 must be continuously energized from an A.C. supply line of electrical characteristics shown on the data plate. Contacts 5-6 and/or 7-8 are available for load duty, and if required, must be wired in Series with the load device or devices, and that series branch circuit connected across a power source compatible with the load. Terminals 9-10 are connected to the moisture sensing probes in the motor marked W1-W2 via the cable provided with the motor.

Operation

Normally the oil surrounding the probes is nonconductive, and the control and seal leakage indicator light will be de-energized. An influx of moisture past the outer seal and into the oil reservoir will change the conductivity of the

oil and this condition will cause the relay to energize, and the seal leakage light will energize to indicate a seal leakage. Load contacts 5-6 and/or 7-8 will also change from their normally open or normally closed position when the control energizes.

Test Procedure

A normally closed pushbutton and neon indicating lamp are provided as a part of the control for testing the moisture sensing components. The motor manufacturer has provided a 330,000 ohm resistor across the probes inside the motor to complete the test. When the test pushbutton is depressed, the neon indicating lamp will be illuminated to indicate:

- (a) Power is supplied to the control.
- (b) The control is operative.
- (c) The wiring to the moisture sensing probes in the motor is intact.

This check does not simulate a leakage. An additional check can be made by removing the enclosure cover and momentarily placing a jumper (or 20,000 ohm resistor) across terminals 9-10 on the control. This will energize the control, and test out the neon indicating lamp and associated voltage dropping resistor across terminal 2 and 4.

CAUTION: Voltage will be present at all terminals on the control when this test is being made.

1. Motor (Immersible)
2. Cap Screw
3. Adapter Plate
4. Cap Screw
5. Shim (As required)
6. Impeller Washer
7. Hex. Hd. Cap Screw (Nylok)
8. Impeller
9. Discharge Casing (Volute)

10. Impeller Key
 11. Hex. Hd. Cap Screw
 12. Hex. Nut
 13. Discharge Flange Gasket
 14. Packing, Flange
 15. Packing, Ring
 16. Ring, Impeller Wearing*
 17. Ring, Casing Wearing*
- *Optional (Not Shown)

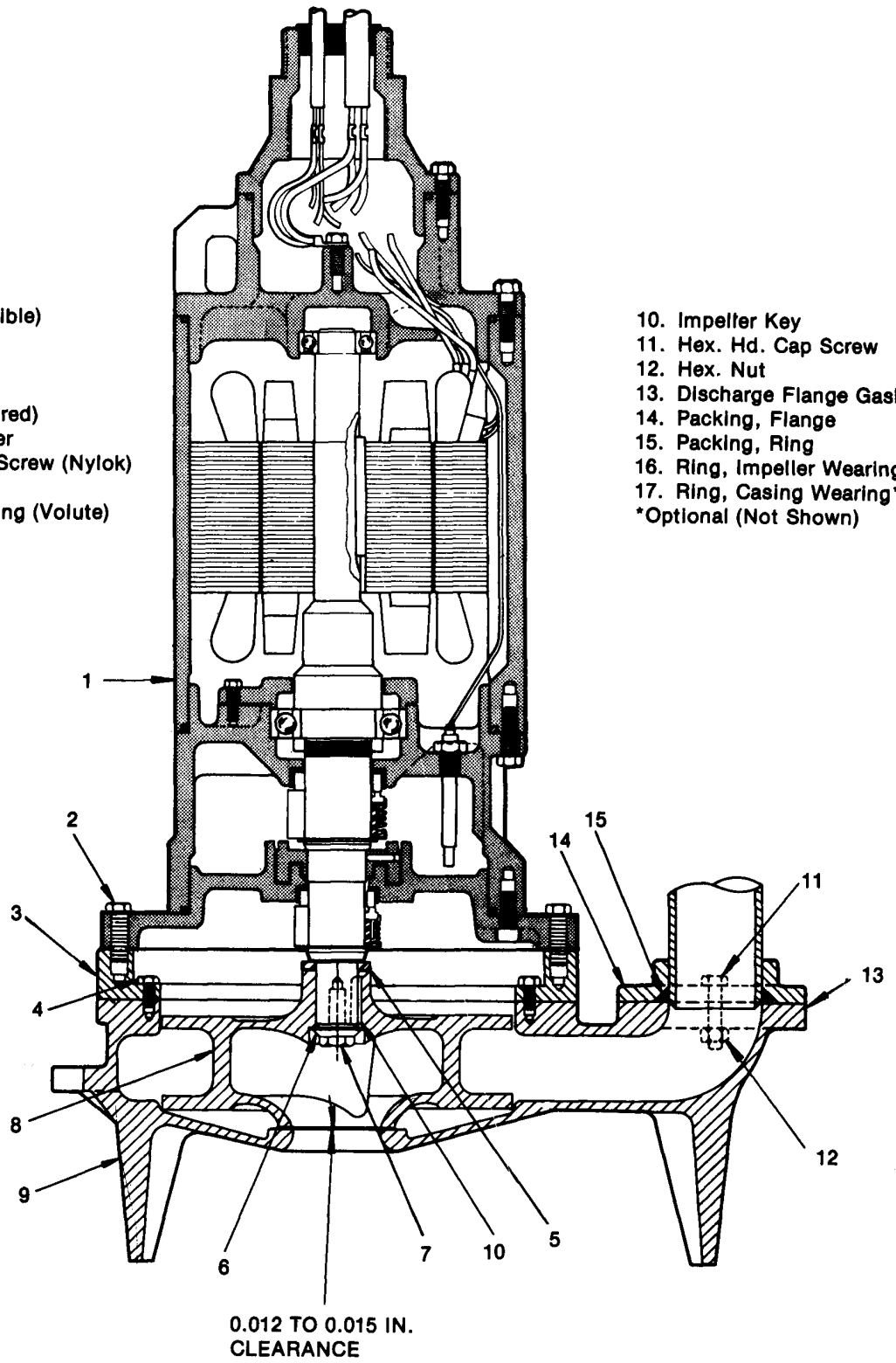

Figure 9. Type UW Sewage Pump



DISASSEMBLY: Disassemble sewage pump as follows (see figure 9):

1. Remove cap screws (2), remove motor (1) impeller (8) from volute casing (9).
2. Block impeller (8) and with socket wrench, unscrew impeller screw (7) by turning counter clockwise (as viewed from pump section).
3. Slide impeller from shaft, retain impeller washer (6) key (10) and shims (5) if used.
4. To remove pump packing ring flange (14) remove bolts (11) and nuts (12).
5. To remove motor adapter plate (3) from volute casing (9) remove cap screws (4).
6. Packing ring (15) may be removed from packing ring flange (14) by prying out with a screwdriver.

CAUTION Refer motor [1] to any authorized Reliance Electric Co. service shop for repairs. It is not recommended that user attempt to make repairs on this type motor under any circumstances. Attempt to repair unit by unauthorized personnel voids warranty.

WARNING Petroleum base cleaning solvents are flammable. Open flame or smoking by personnel in the vicinity of these solvents is extremely hazardous and must not be permitted. Disregard of this warning can result in serious bodily harm and could be fatal.

CLEANING: Pump parts may be cleaned with petroleum base solvent.

1. Metal parts (except motor) may be soaked in solvent if necessary.
2. Use a bristle brush (not metal or wire) to remove tightly adhering deposits.
3. Blow parts dry with clean, dry, compressed air.

INSPECTION: Inspect pump parts for cracks, dents, nicks, scratches or other damage affecting serviceability or sealing.

REPAIR: Remove burrs, nicks or scratches from non-critical surfaces with a fine stone or crocus cloth.

When ordering replacement parts always furnish data stamped on nameplate attached to the pump. Give the index number and part name as shown on figure 9.

ASSEMBLY: Assemble pump parts as follows (see figure 9):

1. Lightly oil new packing ring (15) and insert in flange (14).
2. Place new gasket (13) on casing (9), install flange (14) and attach with 2 each screws (11) and nuts (12). Tighten nuts securely.
3. If removed, align adapter plate (3) on casing (9) and attach with cap screws (4), tightening securely.
4. Install same shims (5), as removed in disassembly, on motor shaft.

Install key (10), slide impeller (8) on shaft, install washer (6) and hex. Head cap screw (7). Restrain impeller and tighten (clockwise) screw securely.

5. Using a hoist, lower motor (1) and impeller to engage casing.

NOTE: If impeller or shims have been replaced, measure clearance with feeler gage between impeller bottom and inside surface of casing at suction port. If not within limits shown on figure 9, use shims (5) as required to obtain proper clearance.

6. Install cap screws (2) and snug hand tight. Manually rotate impeller to check that there is no interference. If there is interference, shift motor, within screw clearance, by tapping with plastic hammer, lightly at point of interference. Continue to rotate impeller and tap around circumference until all interference is removed. Cross tighten screws uniformly and securely.

REINSTALLATION: Refer to Pump Installation instructions at the beginning of this bulletin to reinstall the pump in the basin.

Notice: Materials of construction, specifications dimensions, design features, and application information, where shown in this bulletin, are subject to change and/or modification without notice by Peerless Pump at their option.